

Tonellidesign

The New Modernism
2026 Collection

Tonellidesign

The New Modernism. Collection 2026.

The New Modernism è la nostra interpretazione del vivere e dell'arredare la casa, il senso che cogliamo dell'evoluzione del gusto e degli stili di vita, sommando tra loro la razionale eleganza del design e l'interpretazione della forte espressività delle materie naturali. La collezione rappresenta un modo di rispettare le esigenze dell'abitare contemporaneo e uno stimolo a pensare prodotti che accompagnano le nostre azioni e i nostri momenti all'interno dello spazio domestico.

Questo catalogo racconta un percorso. Non è soltanto una raccolta di prodotti, ma la testimonianza di un'evoluzione, fatta di ricerca, tentativi, intuizioni e scelte coraggiose. Ogni pagina custodisce un passaggio, ogni elemento rappresenta un passo avanti verso una visione sempre più definita.

Anno dopo anno, la collezione si è trasformata: si è affinata nei dettagli, ha trovato nuove forme, ha saputo adattarsi e superare i propri limiti. Ciò che all'inizio era un'idea ha preso consistenza, maturando fino a diventare un insieme coerente, solido e consapevole.

The New Modernism is our interpretation of living and furnishing the home, the sense we grasp of evolving tastes and lifestyles, combining the rational elegance of design with an interpretation of the powerful expressiveness of natural materials. The collection represents a way of respecting the needs of contemporary living and a stimulus to conceive products that accompany our actions and moments within the domestic space.

This catalog tells a story. It is not simply a collection of products, but the testimony of an evolution, made of research, experimentation, intuition and courageous choices. Each page preserves a passage, each element represents a step forward toward an increasingly defined vision.

Year after year, the collection has transformed: it has refined the details, found new forms, adapted, and surpassed its limits. What began as an idea has taken shape, maturing into a coherent, solid and conscious whole.

General index

Indice
generale

Scenery and products index

Indice composizioni e prodotti

Scenery

SC001	6
SC002	30
SC003	54

Products

TAVOLI ALTI / DINING TABLES	
Nuvolari	8
Cathedral	32
Codex	56
MADIE / SIDEBARDS	
Alicante	14
Luma	42
Dimora	64
SEDIE / CHAIRS	
Dea	20
Ekua	50
Sanur	72
LAMPADE / LAMPS	
Transition	26
SPECCHI / MIRRORS	
Mydear	76
BOISERIE / BOISERIE	
Wonderwall	80

SC001

Nuvolari Tavolo / Table
Vetro bronzo, Champagne
Bronze glass, Champagne

Dea Sedia / Chair
Eucalipto, tessuto D001
Eucalipto, fabric D001

Alicante Madia / Sideboard
Laccato opaco Platino, vetro Stopsol bronzo
Matt lacquer Platino, bronze Stopsol glass

Transition Lampada / Lamp
Vetro pyrex, Champagne
Pyrex glass, Champagne

Wonderwall Boiserie / Boiserie
T-Squares specchio bronzo
T-Squares bronze mirror



Nuvolari
dining table

design
Nicola Bonriposi



Nuvolari rilegge un sapere produttivo tradizionale attraverso uno sguardo contemporaneo in cui la componente meccanica, ridotta all'essenziale, scompare alla vista per lasciare emergere un equilibrio misurato tra leggerezza industriale e presenza monolitica. Il piano appare sospeso sopra volumi slanciati, ne deriva un oggetto leggero ma estremamente stabile, pensato per durare nel tempo.

Nuvolari reinterprets traditional manufacturing expertise through a contemporary lens, paring the mechanical component to its bare essentials and allowing a measured balance between industrial lightness and a monolithic presence to emerge. The top appears suspended above sleek volumes, resulting in a lightweight yet extremely stable object, designed to last.

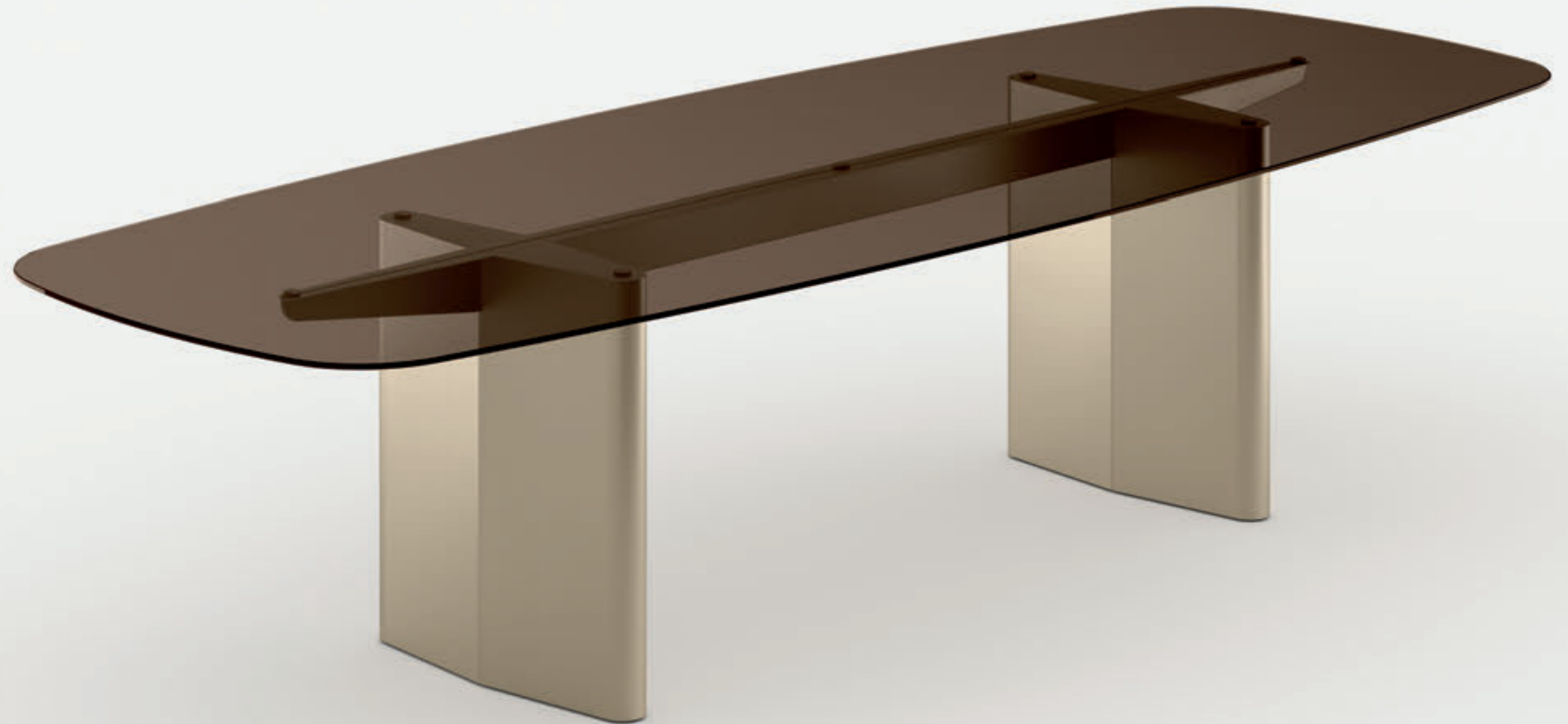



Nuvolari dining table

design
Nicola Bonriposi

INFO TECNICHE / TECHNICAL INFO

Tavolo con basamento in metallo nelle finiture Champagne, Titanio, Dark Brown, Bronzo e nero grafite. I piedini regolabili in altezza nascosti sotto la base, permettono un perfetto livellamento del tavolo. I top in appoggio sono disponibili nelle forme sagomate e rettangolari in vetro temperato extrachiario, fumè e bronzo. Inoltre i top sono anche disponibili in ceramica stratificata vetro nelle finiture Pietra di Savoia antracite bocciardato, Noir desir lucido o opaco, Calacatta oro venato lucido, Pietra Grey opaco, Sahara noir lucido o bocciardato e Travertino bocciardato.

Table with metal base in Champagne, Titanio, Dark Brown, Bronzo, and graphite black finishes. The height-adjustable feet hidden beneath the base allow for perfect table leveling. The loose table tops are available in shaped and rectangular form in extra clear, smoked, and bronze tempered glass. The tops are also available in layered ceramic glass in Pietra di Savoia anthracite bushhammered, Noir Desir polished or matt, Calacatta oro venato polished, Pietra Grey matt, Sahara Noir polished or bushhammered and Travertino bushhammered.

Piano Ceramica
Ceramic Top
200x110
240x115
280x115
320x115

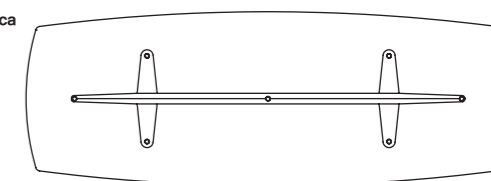

Piano / Top
200x110
220x110
240x110
260x110
280x110
300x120
320x120

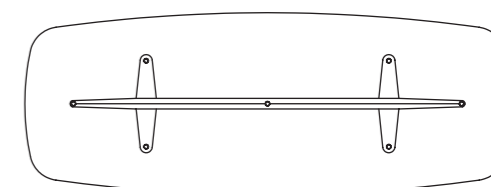

Piano / Top
200x100
220x100
240x100
260x100
280x100
300x100
320x120

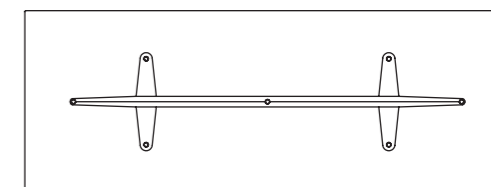

Alicante
sideboard

design
Giovanna Azzarello

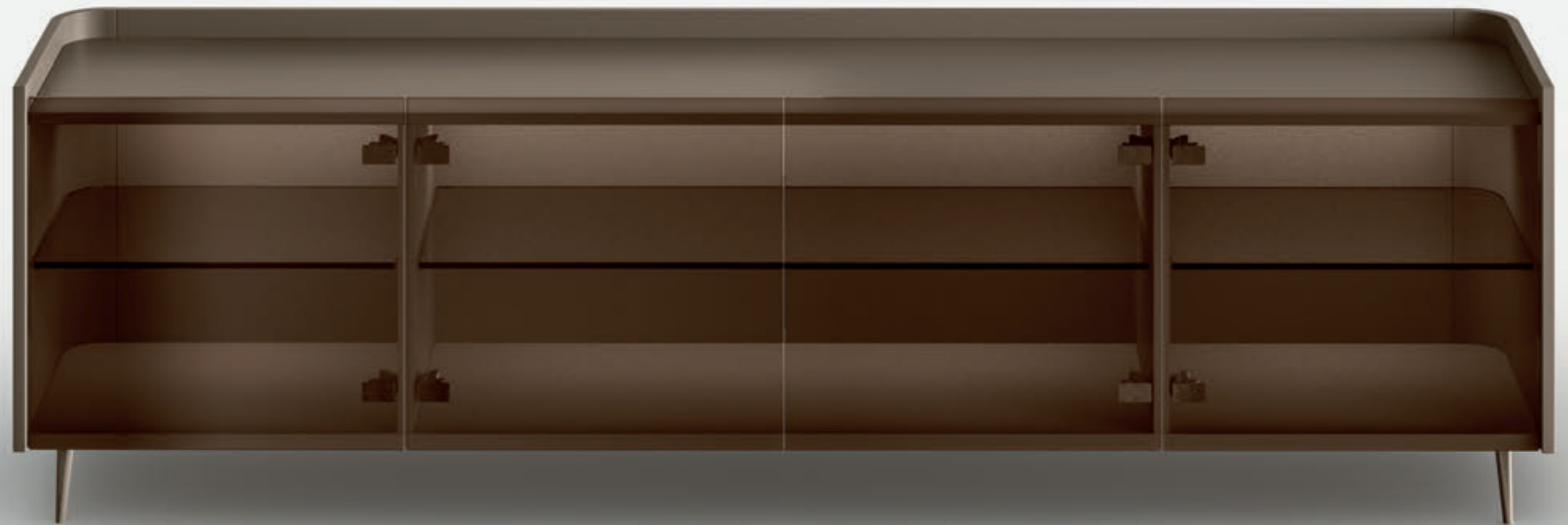



Una madia dalle linee moderne, seppure d'ispirazione classica, che diventa protagonista di spazi living o sale da pranzo. L'ampia scelta di materiali e finiture per le ante battenti trasforma la percezione del mobile da elemento espositivo a contenitore. Il suo interno, elegante e funzionale, è impreziosito dalla luce led.

A sideboard with modern lines, yet classically inspired, that becomes the centerpiece of living or dining spaces. The wide choice of materials and finishes for the hinged doors transforms the perception of the piece from a display element to a storage unit. Its elegant and functional interior is enhanced by LED lighting.



Alicante sideboard

design
Giovanna Azzarello

INFO TECNICHE / TECHNICAL INFO

Madia con struttura in legno curvo laccato opaco nelle finiture Champagne, Titanio, Dark Brown, Platino o Ral. Ante battenti con chiusura soft close disponibili in legno laccato opaco nelle stesse finiture della struttura oppure in vetro extrachiaro, fumè e bronzo o vetro Stopsol fumè e bronzo. Piedi in metallo laccati come struttura, disponibili in due altezze. Optional kit illuminazione interna luce LED 3000K dimmerabile con telecomando per l'accensione.

Sideboard with curved wood structure, matt lacquered in Champagne, Titanio, Dark Brown, Platino or RAL finishes. Hinged doors with soft-close mechanism, available in matt lacquered wood in the same finishes as the structure, or in extra clear, smoked and bronze glass, or smoked and bronze Stopsol glass. Metal legs lacquered to match the structure, available in two heights. Optional internal LED 3000K lighting dimmable with remote control for on/off function.

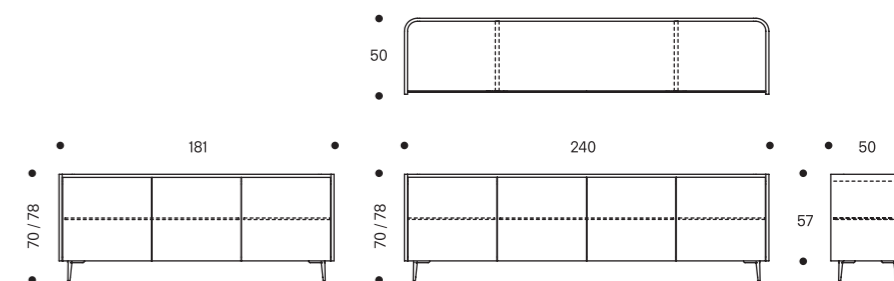

Dea
chair

design
Giovanna Azzarello



Sedia dal design raffinato e distintivo che si ispira alla progettualità degli anni Sessanta, inserendosi con carattere sia nel contesto domestico sia nel contract. Dea fa rivivere la lavorazione artigianale del legno massello nella dimensione industriale. La sedia ha una forma organica e un volume leggerissimo dato dal susseguirsi di linee curve che tracciano un segno avvolgente.

A chair with a refined and distinctive design inspired by 1960s design, it fits perfectly into both residential and contract settings. Dea brings solid wood craftsmanship to life in an industrial context. The chair has an organic shape and a lightweight volume created by a succession of curved lines that create an enveloping silhouette.





Dea chair

design
Giovanna Azzarello

INFO TECNICHE / TECHNICAL INFO

Sedia in legno massello curvato con gambe tornite e struttura a traversi incrociati. Disponibile nelle finiture Siberian Ash, Eucalipto, Rovere Naturale e laccato nero a poro aperto. Seduta sagomata e imbottita, rivestita in tessuto, sfoderabile su richiesta.

Curved solid wood chair with turned legs and a cross-beam structure. Available in Siberian Ash, Eucalipto, Natural Oak and open-pore black lacquer finishes. Contoured and padded seat, upholstered in fabric, removable upon request.

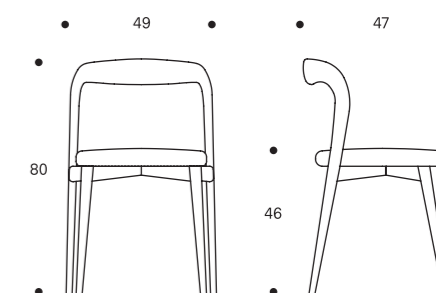

Transition lamp

design
Paolo Benevelli

Lampada a sospensione che si distingue per il suo design contemporaneo e la qualità artigianale. Utilizza la tecnologia LED all'interno di un tubo di vetro rigato, arricchito da terminali in metallo. I singoli elementi lineari di diverse lunghezze e indipendenti tra loro, possono essere utilizzati per creare infinite installazioni offrendo un'esperienza luminosa versatile. Il rosone e il cavo regolabile, permettono di personalizzare l'installazione secondo le specifiche necessità dello spazio.

A pendant lamp distinguished by its contemporary design and quality craftsmanship. It uses LED technology within a ribbed glass tube, enhanced by metal terminals. The individual linear elements of varying lengths, each independent of the other, can be combined to create endless installations, offering a versatile lighting experience. The ceiling canopy and adjustable cable allow for customization according to the specific needs of the space.



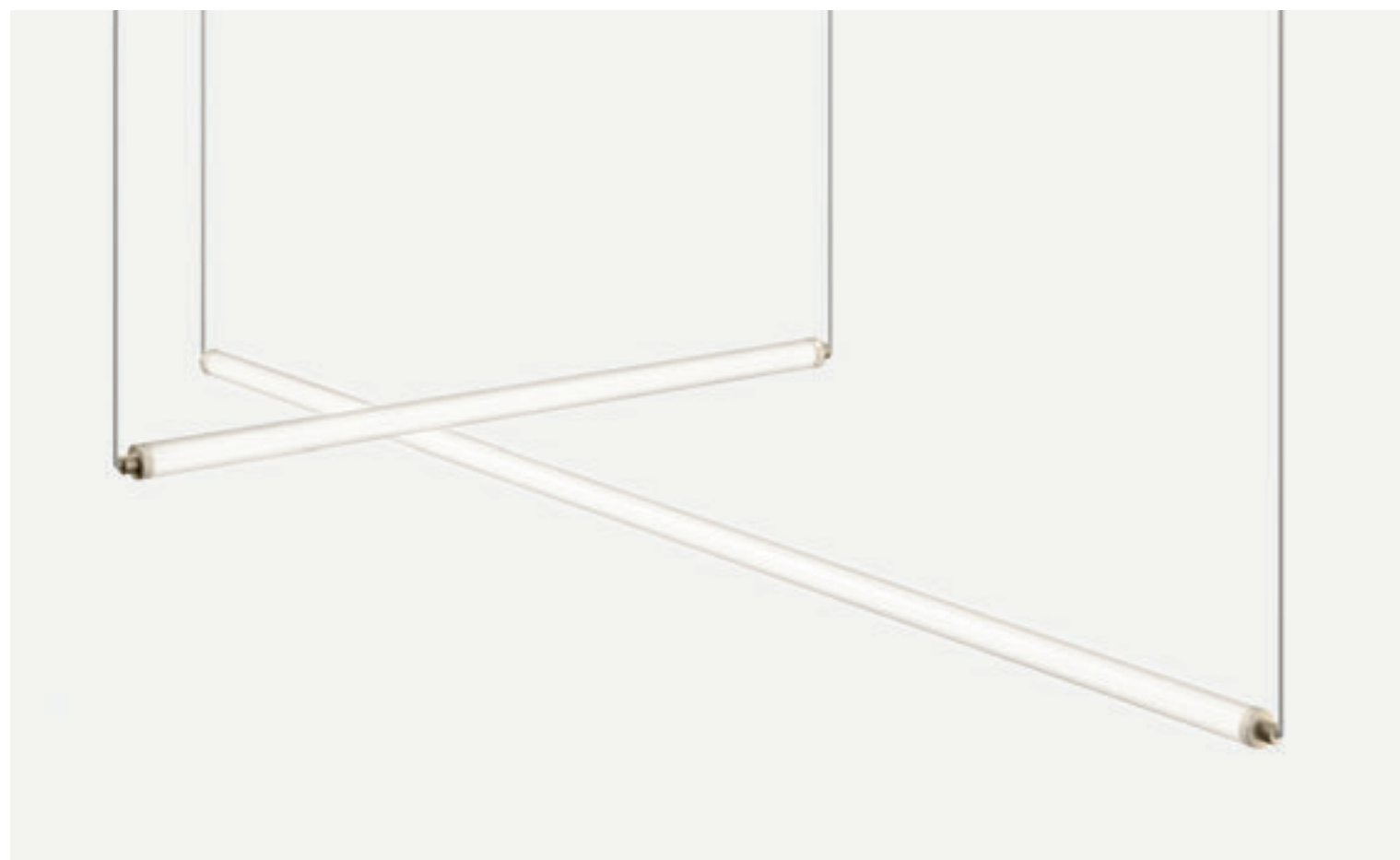

Transition lamp

design
Paolo Benevelli

INFO TECNICHE / TECHNICAL INFO

Collezione di lampade in vetro pyrex rigato disponibile in tre diverse lunghezze. Rosone e terminali in metallo nelle finiture Champagne e Titanio. Cavi di sospensione in pvc trasparente regolabili in altezza fino a tre metri. Sistema di illuminazione a luce LED COB 3000K, dimmerabile.

A collection of ribbed Pyrex glass lamps available in three different lengths. Metal ceiling canopy and terminals in Champagne and Titanio finishes. Transparent pvc suspension cables adjustable in height up to three meters. Dimmable 3000K COB LED lighting system.

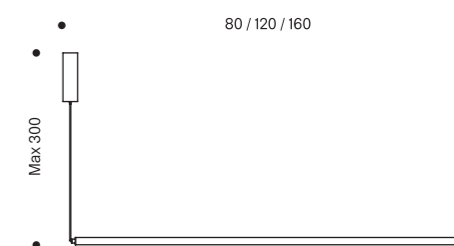

SC002

Cathedral Tavolo / Table
Vetro bronzo, Bronzo
Bronze glass, Bronzo

Ekua Sedia / Chair
Siberian Ash, tessuto H017
Siberian Ash, fabric H017

Luma Madia / Sideboard
Specchio bronzo, specchio bronzo
Bronze mirror, bronze mirror

Transition Lampada / Lamp
Vetro pyrex, Champagne
Pyrex glass, Champagne

Wonderwall Boiserie / Boiserie
T-Squares specchio bronzo
T-Squares bronze mirror



Cathedral
dining table

design
Studio 14

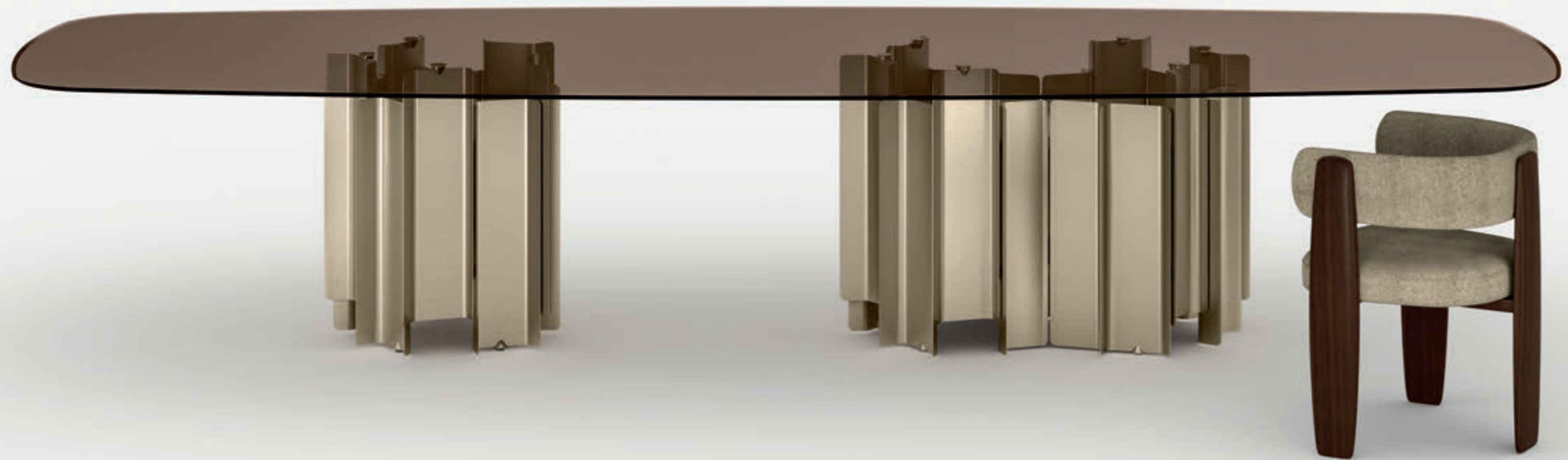



La struttura scultorea e raffinata del tavolo Cathedral evoca la maestosità di una cattedrale. Il contrasto fra la solidità della base in metallo e il piano in vetro conferisce al tavolo un carattere sofisticato ideale per ambienti moderni ed eleganti. La cura degli elementi di collegamento in metallo della base, li rende dettagli unici e raffinati.

The refined, sculptural structure of the Cathedral table evokes the majesty of a cathedral. The contrast between the solid metal base and the glass top gives the table a sophisticated character, ideal for modern and elegant spaces. The attention to detail in the metal connecting elements of the base makes them unique and refined details.

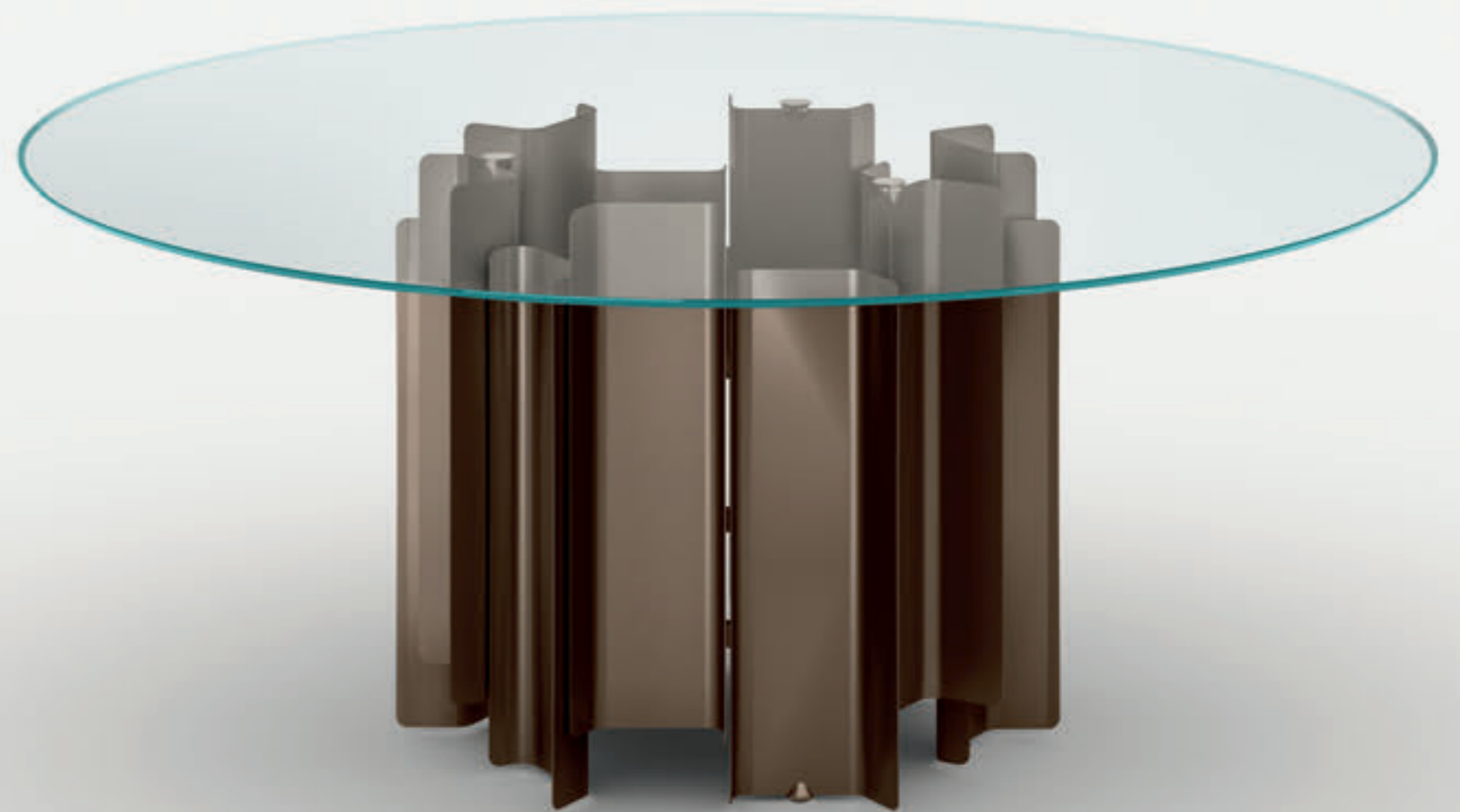

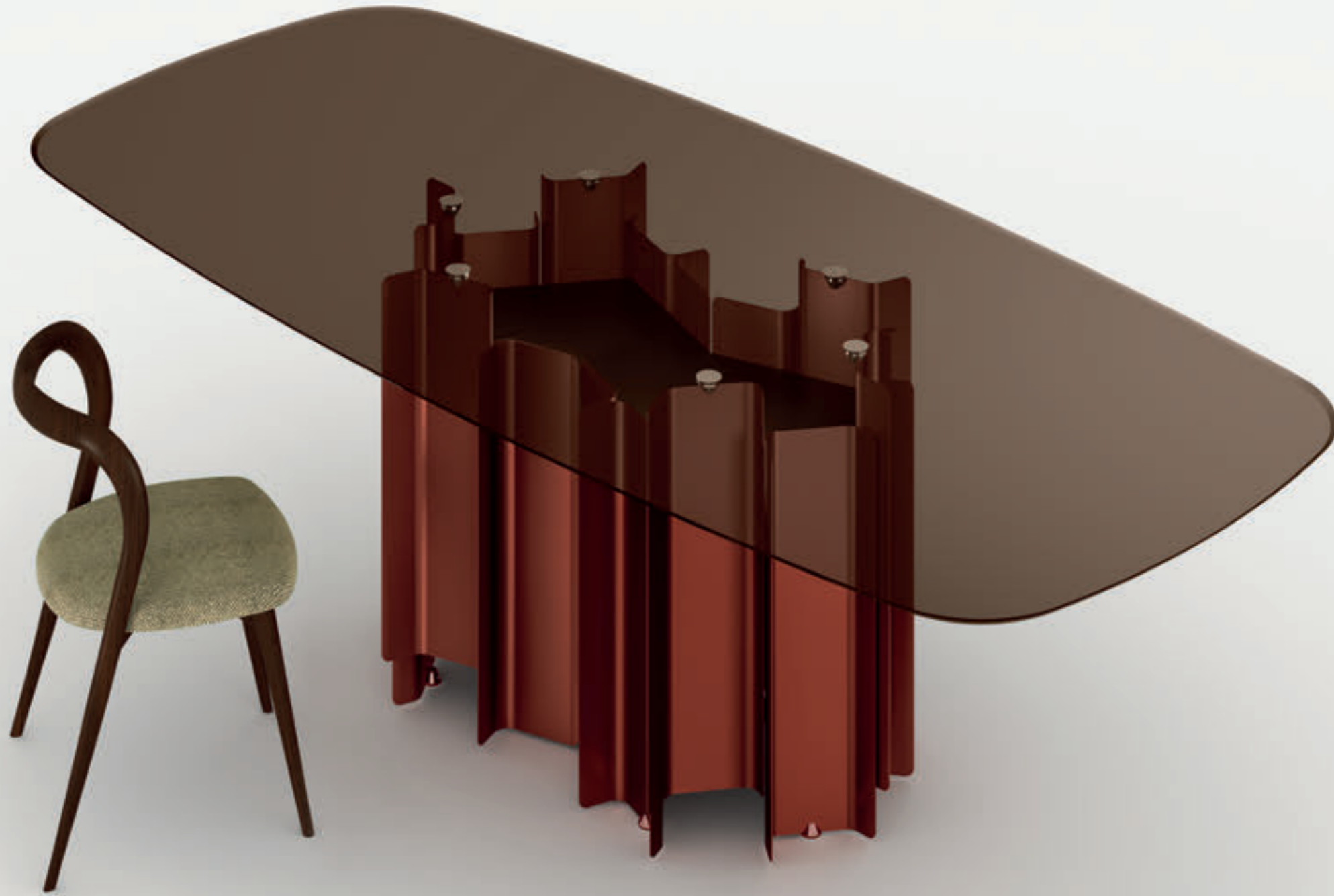

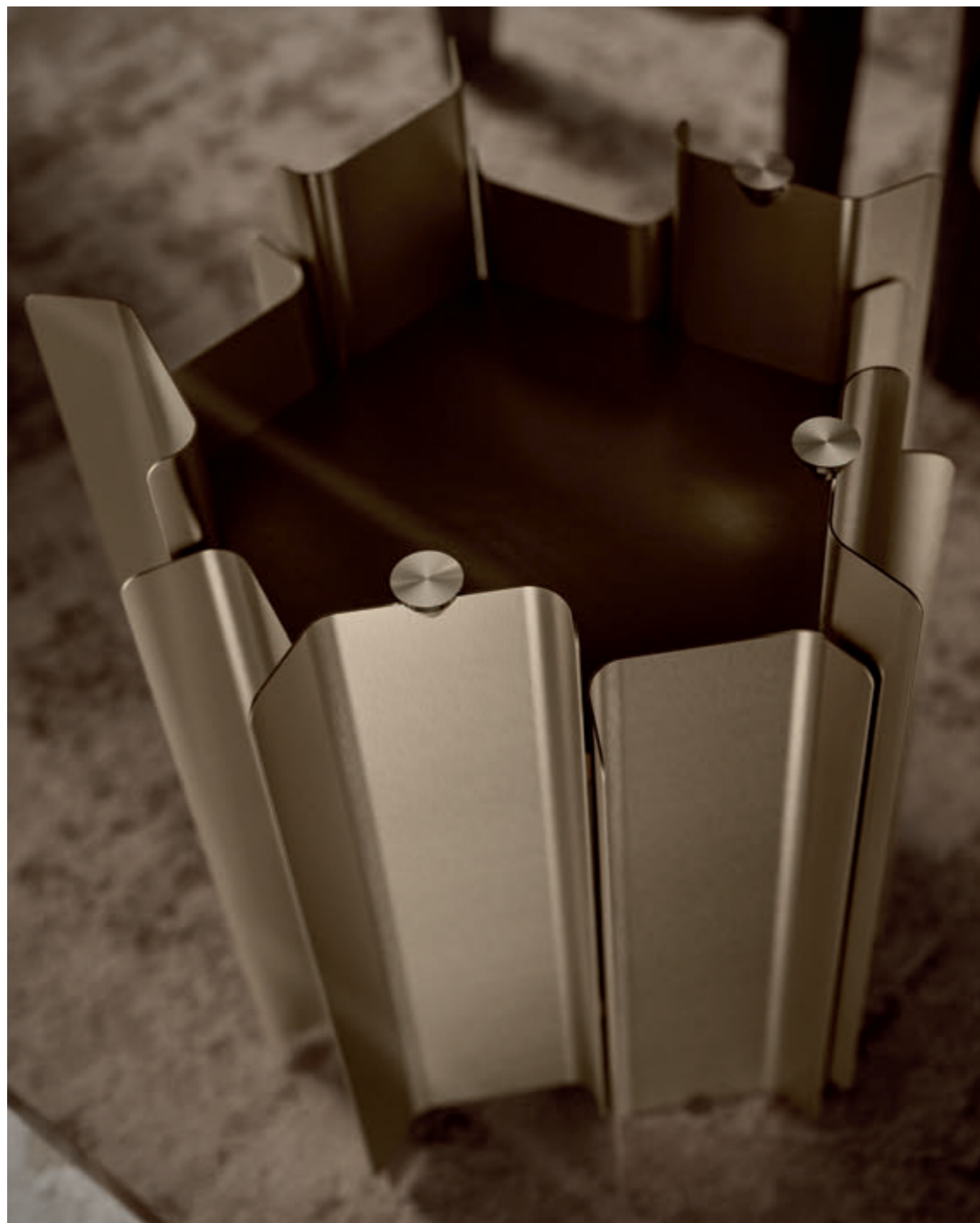

Cathedral dining table

design
Studio 14

INFO TECNICHE / TECHNICAL INFO

Tavolo con piano in vetro temperato sagomato o rotondo disponibile nelle finiture extrachiaro, fumè o bronzo, fissato alla base tramite piastre di acciaio. Il basamento è composto da elementi verticali in metallo curvato verniciati nelle finiture Champagne, Titanio, Dark Brown, Bronzo, Red Jaipur e nero grafite. I dettagli in metallo, sempre nella stessa finitura della base, permettono un perfetto livellamento del tavolo. Combinando più basamenti, è possibile realizzare tavoli di grandi dimensioni.

Table with shaped or round tempered glass top available in extra clear, smoked or bronze finishes, secured to the base with steel plates. The base is composed of vertical curved metal elements painted in Champagne, Titanium, Dark Brown, Bronze, Red Jaipur and graphite black. The metal details, always in the same finish as the base, allow for perfect leveling of the table. By combining multiple bases, it is possible to create large tables.

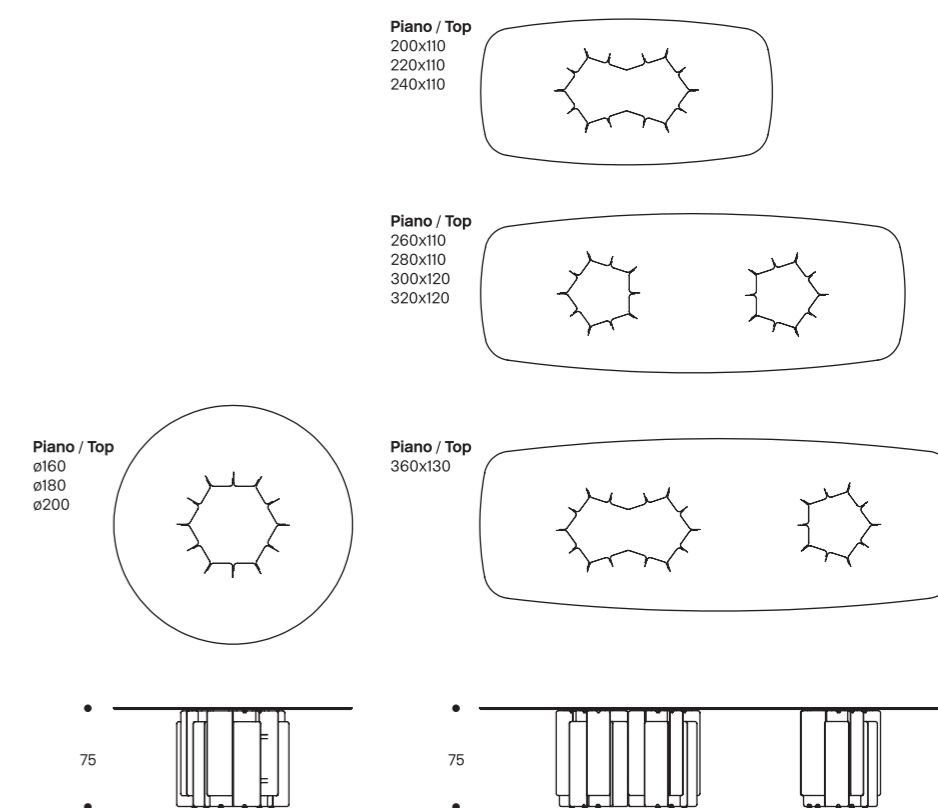

Luma
sideboard

design
Massimo Castagna





Madia che trae ispirazione dal design italiano degli anni '50 con una silhouette dai dettagli curvilinei. Fortemente caratterizzante è la forma dell'anta specchio, che svetta rispetto alla scocca contenitiva, andando a disegnare una sagoma dagli angoli dolcemente smussati e rastremati. La struttura completamente rivestita a specchio, genera un forte impatto visivo che afferma una spiccata tridimensionalità dell'estetica, una presenza fisica prima ancora che decorativa.

A sideboard inspired by 1950s Italian design, featuring a silhouette with curved details. The distinctive shape of the mirrored door stands out from the surrounding structure, creating a shape with gently rounded and tapered corners. The fully mirrored structure creates a strong visual impact, asserting a distinctly three-dimensional aesthetic, a physical presence rather than a decorative one.





Luma sideboard

design
Massimo Castagna

INFO TECNICHE / TECHNICAL INFO

Madia con struttura in legno rivestita esternamente in specchio nelle finiture specchio, specchio fumè e specchio bronzo. Ante battenti in legno laccato con chiusura soft close e frontale in specchio di forte spessore dai bordi smussati. I frontali sono anche disponibili in specchio con spessore ridotto e bordo dritto. Ripiani interni in vetro extrachiaro su ogni vano.

Sideboard with a wooden frame covered in mirrored exteriors in mirror, smoked mirror and bronze mirror finishes. Lacquered wooden hinged doors with soft-close mechanism and thick mirror fronts with beveled edges. The fronts are also available in thinner mirror with straight edges. Extra-clear glass shelves in each compartment.

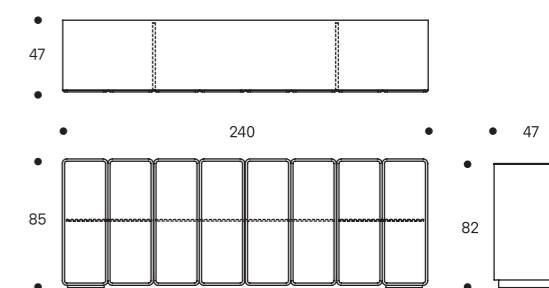

Ekua chair

design
Massimo Castagna

Appartiene ad un gusto estetico fortemente contemporaneo. Casual ed elegante, esprime un raffinato equilibrio, unendo la solida struttura in legno massello tornito alla matericità morbida e sensuale della seduta e dello schienale rivestiti in tessuto. La linea curva dello schienale generosamente imbottito trasmette un piacevole effetto di abbraccio.

It reflects a strongly contemporary aesthetic. Casual and elegant, it expresses a refined balance, combining a solid turned wood frame with the soft, sensual texture of the fabric-upholstered seat and backrest. The curved line of the generously padded backrest conveys a pleasant, embracing effect.





Eku chair

design
Massimo Castagna

INFO TECNICHE / TECHNICAL INFO

Sedia con struttura a tre gambe in legno massello tornito e traversi incrociati. Disponibile nelle finiture Siberian Ash, Eucalipto, Rovere Naturale e laccato nero a poro aperto. Seduta e schienale sagomati e imbottiti, rivestiti in tessuto; seduta sfoderabile su richiesta.

Chair with three-legged frame in turned solid wood and cross-beam structure. Available in Siberian Ash, Eucalipto, Natural Oak and open-pore black lacquer finishes. Contoured and padded seat and backrest, upholstered in fabric; removable seat covers available upon request.

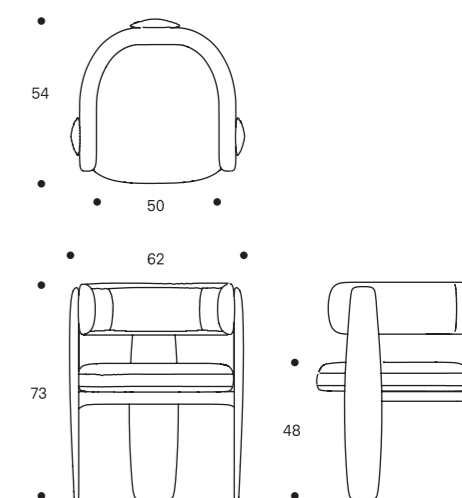

SC003

Codex Tavolo / Table
Vetro satinato Dark Brown, Eucalipto, Dark Brown
Frosted Dark Brown glass, Eucalipto, Dark Brown

Sanur Sedia / Chair
Eucalipto, tessuto D007
Eucalipto, fabric D007

Dimora Madia / Sideboard
Eucalipto, Champagne
Eucalipto, Champagne

Transition Lampada / Lamp
Vetro pyrex, Champagne
Pyrex glass, Champagne

Mydear Specchio / Mirror
Eucalipto, specchio bronzo
Eucalipto, bronze mirror



Codex
dining table

design
Giulio Mancini

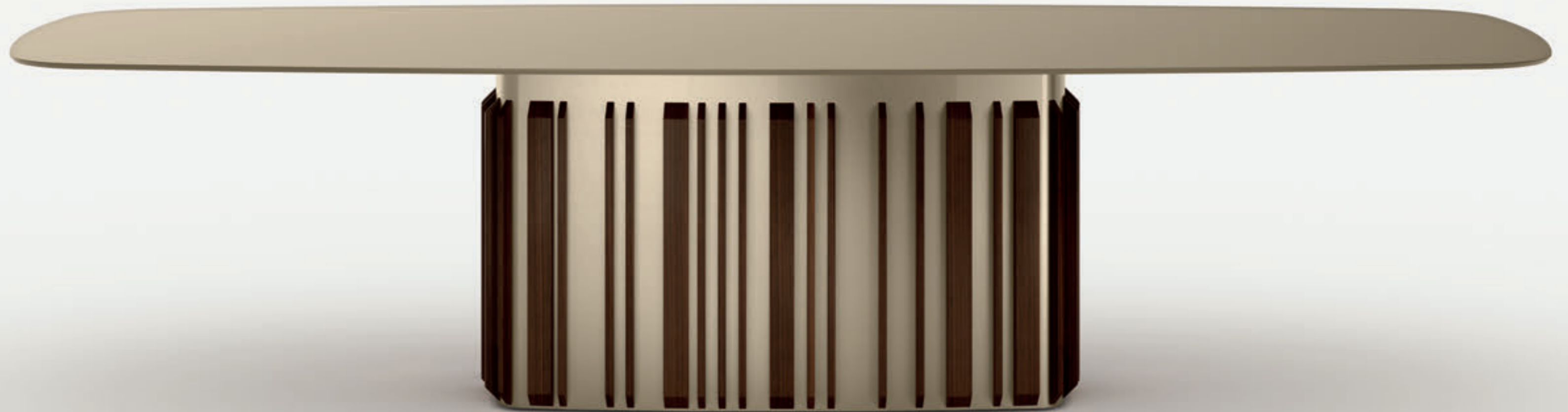

La forma morbida e sinuosa del basamento di questo tavolo è arricchita dall'alternanza dei listelli in legno massello di diversa misura e spessore, finemente lavorati e modellati. I top in vetro laccato dal bordo bisellato permettono di creare soluzioni cromatiche in abbinamento o in contrasto con le finiture di legno e di metallo del basamento.

The soft, sinuous shape of this table's base is enhanced by alternating solid wood slats of varying sizes and thicknesses, finely crafted and shaped. The lacquered glass tops with beveled edges allow for color combinations that match or contrast with the wood and metal finishes of the base.

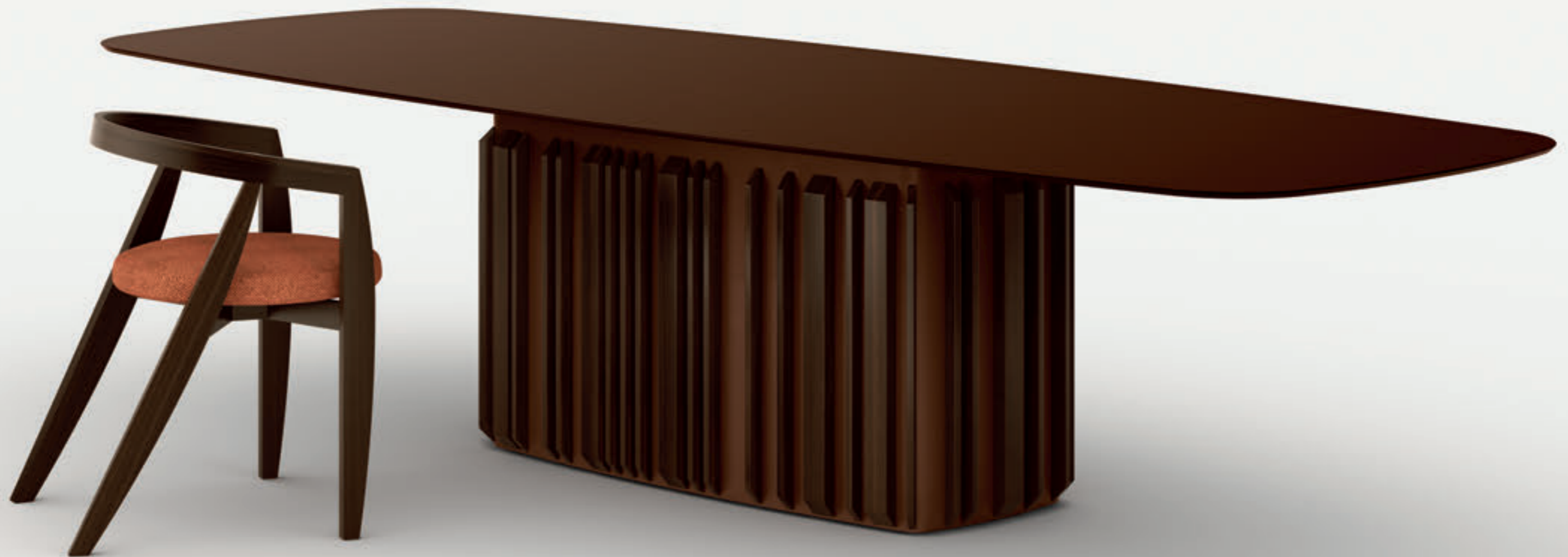



Codex dining table

design
Giulio Mancini

INFO TECNICHE / TECHNICAL INFO

Tavolo con basamento centrale in metallo e listelli in legno massello. Metalli disponibili nelle finiture Champagne, Titanio, Dark Brown, Bronzo e nero grafite. Legni disponibili nelle finiture Eucalipto, Siberian Ash, Noce Canaletto e Rovere Naturale. I top sono disponibili nella forma sagomata con bordo bisellato in vetro temperato extrachiaro satinato laccato Champagne, Titanio, Dark Brown, Platino e Nero o marmo spazzolato opaco nelle varianti Nero Marquina, Bianco Carrara, Arabescato Orobico Gold, Sahara Noir, Tropikal Storm, Domus White e Travertino Romano. Inoltre i top sono anche disponibili in ceramica stratificata vetro nelle finiture Pietra di Savoia antracite bocciardato, Noir desir lucido o opaco, Calacatta oro venato lucido, Pietra Grey opaco, Sahara noir lucido o bocciardato e Travertino bocciardato. I piedini regolabili in altezza nascosti sotto la base, permettono un perfetto livellamento del tavolo.

Table with central metal base and solid wood slats. Metals available in Champagne, Titanio, Dark Brown, Bronzo and Graphite Black finishes. Woods available in Eucalipto, Siberian Ash, Canaletto Walnut and Natural Oak finishes. The tops are available shaped form with beveled edge in extra clear satinized tempered glass lacquered in Champagne, Titanio, Dark Brown, Platino and Black, or in matt brushed marble in Nero Marquina, Bianco Carrara, Arabescato Orobico Gold, Sahara Noir, Tropikal Storm, Domus White and Travertino Romano. The tops are also available in layered glass ceramic in the finishes: Pietra di Savoia anthracite bushhammered, Noir Desir polished or matt, Calacatta oro venato polished, Pietra Grey matt, Sahara Noir polished or bushhammered and Travertino bushhammered. The height-adjustable feet hidden under the base allow for perfect leveling of the table.



Piano Vetro / Glass Top
200x110 / 220x110 / 240x110 / 260x110 / 280x110
300x120 / 320x120

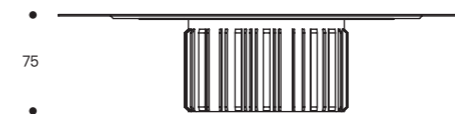
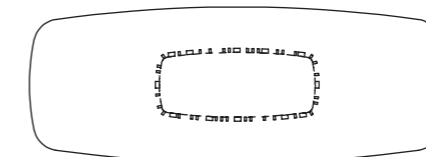

Piano Ceramica / Ceramic Top
200x110 / 240x115 / 280x115 / 320x115

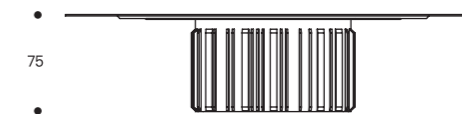
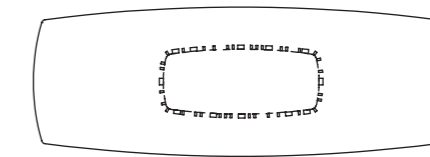

Piano Marmo / Marble Top
200x115 / 220x115 / 240x120 / 260x120 / 280x120

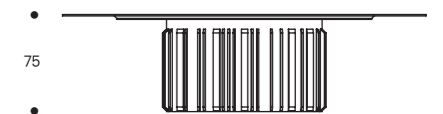
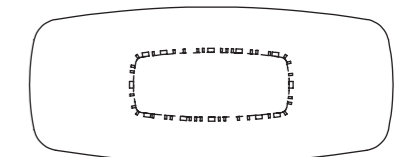

Dimora
sideboard

design
Debonademeo studio



La madia è definita dal volume curvo degli schienali in metallo che avanzano fino ad abbracciarne tutta la struttura centrale in legno, creando un particolare effetto di sospensione. Elemento caratterizzante sono i contrasti, espressi da un design sinuoso, e da abbinamenti materici personalizzabili ed eclettici. La cura dei dettagli interni completati dall'illuminazione interna, la rendono un elemento d'arredo pratico e funzionale.

The sideboard is defined by the curved volume of the metal back panels that extend to embrace the entire central wooden structure, creating a unique suspended effect. Contrasts are its defining feature, expressed through a sinuous design and through customizable and eclectic combinations of materials. The attention to interior details, complemented by internal lighting, make it a practical and functional piece of furniture.







Dimora sideboard

design
Debonademeo studio

INFO TECNICHE / TECHNICAL INFO

Madia con struttura in metallo curvato e legno. Metallo nelle finiture Champagne, Titanio, Dark Brown e Bronzo. Top, base e ante battenti nelle finiture legno Siberian Ash, Eucalipto e Noce Canaletto o laccato opaco Champagne, Titanio, Dark Brown, Platino o Ral. Ante battenti con apertura push pull. Optional kit illuminazione interna luce LED 3000K con sensore.

Sideboard with curved metal and wood structure. Metal in Champagne, Titanio, Dark Brown and Bronzo finishes. Top, base, and hinged doors in Siberian Ash, Eucalipto and Canaletto Walnut wood finishes or in matt Champagne, Titanio, Dark Brown, Platino or RAL lacquer. Hinged doors with push-pull opening. Optional internal lighting kit 3000K LED light with sensor.

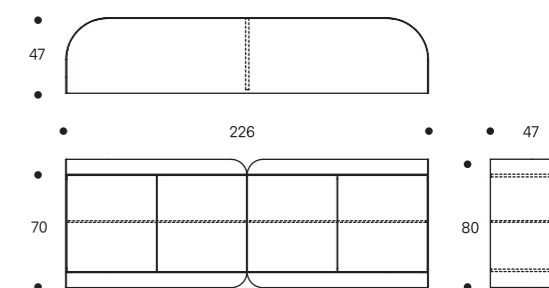

Sanur chair

design
Giovanni D'Ambrosio

La struttura per questa sedia, interamente costruita in massello curvato e modellato, è essenziale e geometrica. Sintesi perfetta tra tradizione e modernità, in un equilibrio di maestria artigianale e processi industriali. Armonia e rigore convivono in un design dalle linee pulite ed eleganti che contribuiscono a delineare un'estetica dinamica e distintiva. La seduta generosamente imbottita insieme allo schienale incavato e adeguatamente inclinato, assicurano il massimo confort.

The frame of this chair, constructed entirely from curved and shaped solid wood, is simple and geometric. It perfectly blends tradition and modernity, balancing craftsmanship and industrial processes. Harmony and precision coexist in a design with clean, elegant lines that contribute to a dynamic and distinctive aesthetic. The generously padded seat and the recessed, appropriately inclined backrest ensure maximum comfort.





Sanur chair

design
Giovanni D'Ambrosio

INFO TECNICHE / TECHNICAL INFO

Sedia in legno massello curvato con gambe inclinate e struttura a traversi incrociati. Disponibile nelle finiture Siberian Ash, Eucalipto, Rovere Naturale e laccato nero a poro aperto. Seduta sagomata e imbottita, rivestita in tessuto., sfoderabile su richiesta.

Chair in curved solid wood with slanted legs and a cross-beam structure. Available in Siberian Ash, Eucalipto, Natural Oak and open-pore black lacquer finishes. Contoured and padded seat, upholstered in fabric, removable upon request.

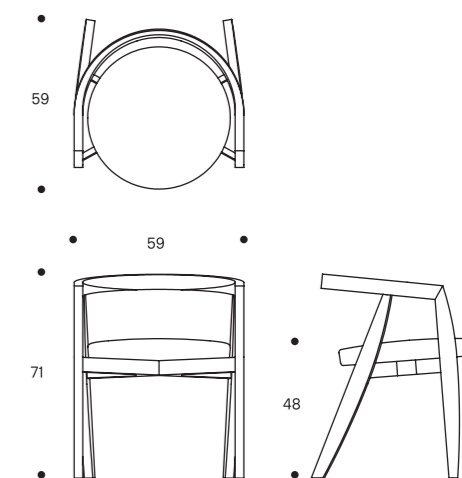

Mydear mirror

design
Alessandro Corina

Un segno continuo che si avvolge nello spazio dà forma a Mydear, uno specchio in cui la linea diventa protagonista. La cornice segue un percorso fluido e ininterrotto, come un nastro che si piega con naturalezza generando una geometria morbida e dinamica. Il legno, nella sua purezza materica, accompagna questo movimento in un equilibrio sottile tra presenza e percezione, tra struttura e immagine. In Mydear la forma non è mai statica: è un gesto che scorre, avvolge e definisce lo spazio, trasformando lo specchio in un elemento architettonico capace di dialogare con l'ambiente con continuità.

A continuous line that wraps around space gives shape to Mydear, a mirror where lines take center stage. The frame follows a fluid and uninterrupted path, like a ribbon that bends naturally, generating a soft and dynamic geometry. Wood, in its material purity, accompanies this movement in a subtle balance between presence and perception, between structure and image. In Mydear, form is never static: it is a gesture that flows, envelops, and defines the space, transforming the mirror into an architectural element capable of seamlessly interacting with its surroundings.





Mydear mirror

design
Alessandro Corina

INFO TECNICHE / TECHNICAL INFO

Specchio da parete con struttura in legno curvato nelle finiture Eucalipto, Siberian Ash e Noce Canaletto. Specchio piano nelle finiture specchio, specchio fume' e specchio bronzo. Optional kit illuminazione LED COB 3000K, su lato superiore e inferiore, con accensione e regolazione dell'intensità luminosa, touch sullo specchio.

Wall mirror with curved wood frame in Eucalipto, Siberian Ash and Canaletto Walnut finishes. Flat mirror clear, smoked or bronze finishes. Optional 3000K COB LED lighting kit on the top and bottom, with touch-sensitive switch and dimmer on the mirror.

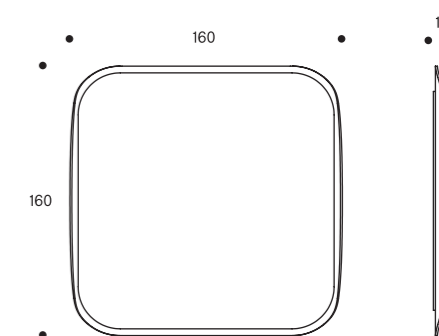

Wonderwall boiserie, doors and partitions

design

Massimo Castagna

Dalla passione per il vetro, nasce un nuovo concetto di decorazione per pareti e divisione di ambienti che si trasformano in spazi dinamici, moderni ed emozionanti. L'equilibrio tra innovazione tecnologica e design su misura permette di creare atmosfere uniche, capaci di stupire e ispirare. Boiserie, vetrate fisse, porte scorrevoli e pivot diventano gli elementi compositivi per disegnare aree con totale libertà e ampia personalizzazione.

From a passion for glass comes a new concept of wall decoration and room division, transforming them into dynamic, modern, and exciting spaces. The balance between technological innovation and custom design allows for the creation of unique atmospheres that amaze and inspire. Paneling, fixed glass panels, sliding and pivot doors become the compositional elements for designing spaces with complete freedom and extensive customization.









Wonderwall boiserie, doors and partitions

design
Massimo Castagna

Info Tecniche / Technical Info

Sistema di boiserie, vetrate fisse, porte scorrevoli e pivot in vetro fuso temperato con profili in alluminio nelle finiture Nero, Carbon, Bronzo, Rame, Champagne e Sabbia. Sistema realizzabile su misura con moduli di dimensione massima pari a 300 cm. Per info tecniche vedi listino.

A system of boiserie, fixed glass panels, sliding doors and pivot doors, in tempered fused glass with aluminium profiles in Nero, Carbon, Bronzo, Rame, Champagne and Sabbia finishes. The system can be custom-made with modules measuring up to 300 cm. For technical information, see the price list.

**Realizzato in collaborazione con Barausse.
Made in collaboration with Barausse.**

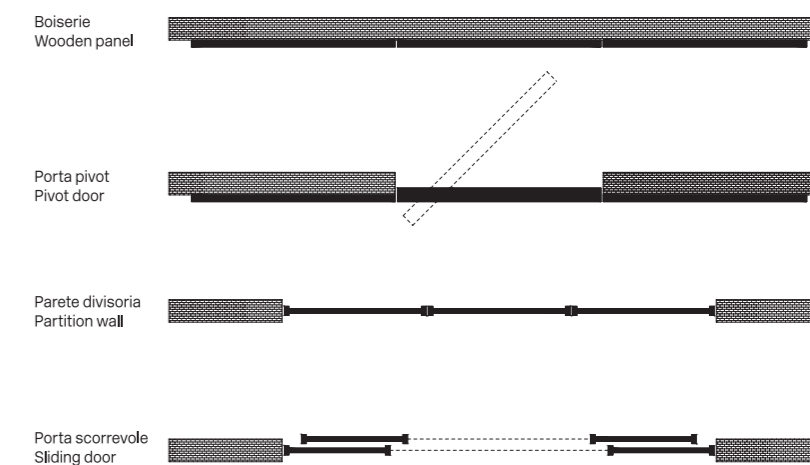

**Materials
collection**
Collezione
materiali

Materials index
Indice materiali

Vetro / Glass **90**

Specchio / Mirror
Finiture Metallo / Metal Finishing **91**

Marmo / Marble
Legno / Wood **92**

Tessuto / Textile **93**

Vetro / Glass

Extrachiaro
Extra clear



Vetro Extrachiaro satinato
retrolaccato champagne
Backlacquered champagne
extra clear frosted glass



Fumè
Smoked



Vetro Extrachiaro satinato
retrolaccato Titanio
Backlacquered Titanio
extra clear frosted glass



Bronzo
Bronze

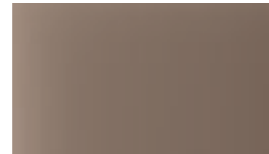

Vetro Extrachiaro satinato
retrolaccato Dark Brown
Backlacquered Dark Brown
extra clear frosted glass



Vetro Extrachiaro satinato
retrolaccato Platino
Backlacquered Platino
extra clear frosted glass

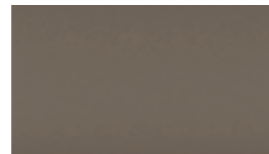

Vetro Wonderwall / Wonderwall glass

T-Stripes Extrachiaro specchio
Extraclear T-Stripes mirror



T-Stripes Fumè specchio
Smoked T-Stripes mirror



T-Stripes Bronzo specchio
Bronze T-Stripes mirror



T-Stripes Fumè
Smoked T-Stripes

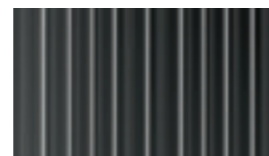

T-Stripes Bronzo
Bronze T-Stripes



T-Squares Extrachiaro specchio
Extraclear T-Squares mirror



T-Squares Fumè specchio
Smoked T-Squares



T-Squares Bronzo specchio
Bronze T-Squares mirror



T-Squares Fumè
Smoked T-Squares



T-Squares Bronzo
Bronze T-Squares



Specchio / Mirror

Specchio
Mirror



Fumè
Smoked

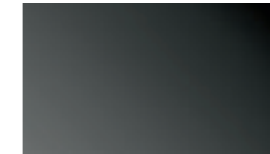

Bronzo
Bronze



Finiture su metallo / Metal finishing

Titanio



Champagne



Dark Brown



Nero / Black



Bianco / White



Bronzo



Red Jaipur



Collezione materiali
Materials collection

Marmo / Marble

Tropical storm
FINITURA SPAZZOLATA
BRUSHED FINISHING



Arabescato Orobico Gold
FINITURA SPAZZOLATA
BRUSHED FINISHING



Domus White
FINITURA SPAZZOLATA
BRUSHED FINISHING



Nero Marquinia
FINITURA SPAZZOLATA
BRUSHED FINISHING



Bianco Carrara
FINITURA SPAZZOLATA
BRUSHED FINISHING



Sahara Noir
FINITURA SPAZZOLATA
BRUSHED FINISHING

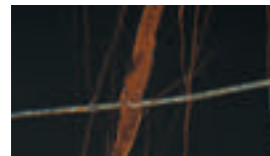

Travertino Sibillino
FINITURA SPAZZOLATA
BRUSHED FINISHING



Legno / Wood

Siberian Ash



Eucalipto



Rovere Naturale
Natural Oak



Noce canaletto
Canaletto walnut



Dea chair / Ekua chair / Sanur chair
tessuto / textile

La riproduzione delle finiture su carta può riportare leggere differenze cromatiche rispetto agli originali. Finishes reproductions on paper can differ slightly from the original ones.

Tessuto / Textile D

D 002



D 001



D 005

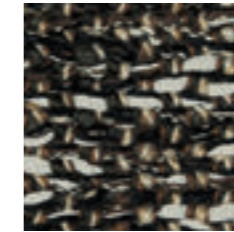

D 004

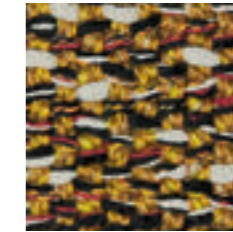

D 007

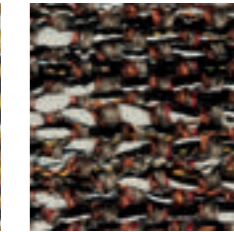

D 006

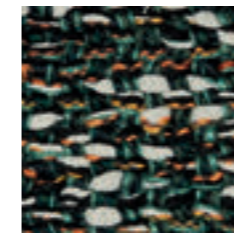

D 003

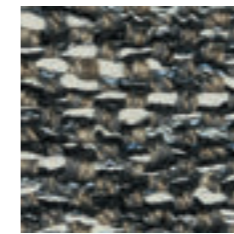

Tessuto / Textile H

H 021



H 018

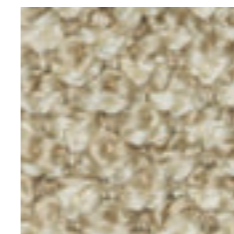

H 017

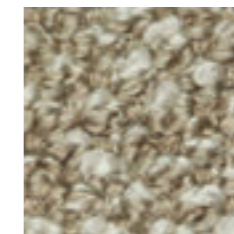

H 027

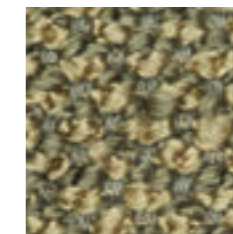

H 015

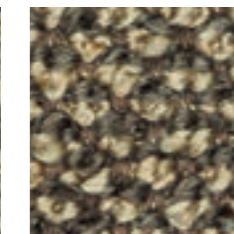

H 013

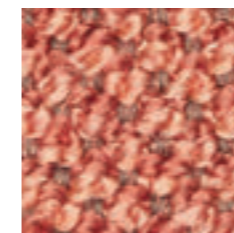

H 012

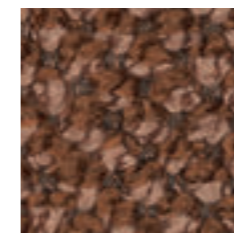

H 004

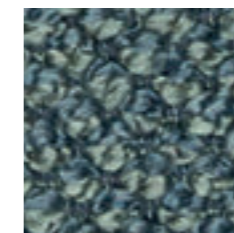

H 008



H 010

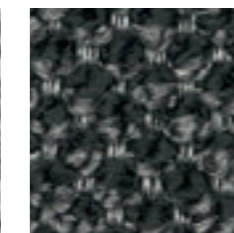

Tessuto / Textile B



Tessuto / Textile C

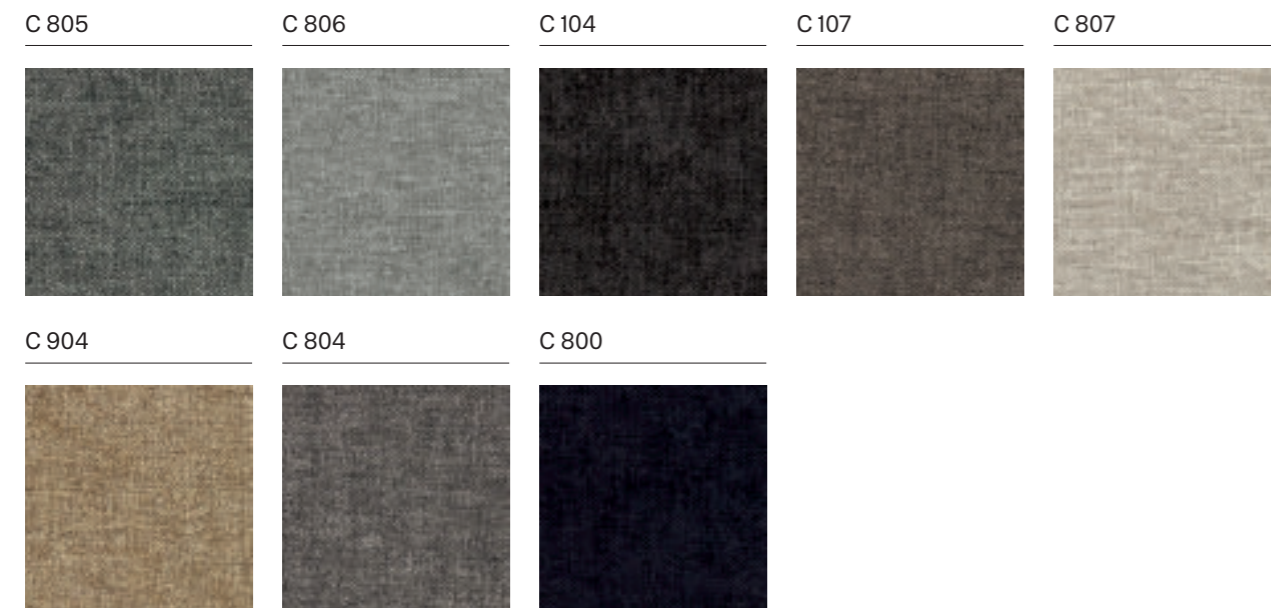

Tessuto / Textile F



Tessuto / Textile P



Tonellidesign

Tonelli Design

T.D. Srl
via Casali 40/42
61122 - Pesaro (PU) Italy
tel. +39 0721 481172
www.tonellidesign.it
info@tonellidesign.it
export@tonellidesign.it

-  Tonelli design
-  Tonelli_Design
-  tonelli-design
-  Tonelli Design-Official

The New Moderinsm.

art direction

Massimo Castagna / AD Architettura

digital images

Garage121

graphic design

Enrico Severi Design

post production

MIC Studio

print

Gruppo Leardini

Published April 2026

Tonelli Design / All rights reserved

Tonellidesign