

AL

B

ED

LISTINO

PRICE

BOOK

2024  
v.1.6

UN SISTEMA  
COMPLETO  
DI SOLUZIONI  
TECNICHE AL  
SERVIZIO DEL  
PROGETTISTA.

#### LA NOSTRA OFFERTA

Siamo un'Azienda di complementi e sistemi in alluminio e vetro, dal 1964. Siamo un'Azienda produttiva e ne andiamo fieri perché è la nostra forza. Tutti i nostri prodotti sono interamente realizzati in Italia con materie prime di altissima qualità e riciclabili al 100%. Grazie alla collaborazione coi nostri clienti, la proposta di Albed negli anni è diventata un sistema completo di soluzioni tecniche al servizio del progettista.

#### OUR OFFER

We are a company of furnishing accessories and systems in aluminum and glass, since 1964. We are a manufacturing company and we are proud of it because it is our strength. All our products are entirely produced in Italy and made with 100% recyclable raw materials of the highest quality. Over the years, Albed's proposal has become a complete system of technical solutions at the designer's service.

A COMPLETE  
SYSTEM OF  
TECHNICAL  
SOLUTIONS,  
SERVING THE  
DESIGNER

# Trova la tua soluzione rispondendo a tre domande

Find your solution by answering  
three questions

---

1. QUALE SOLUZIONE CERCHI ?
2. COME LA SOLUZIONE SI INTEGRA NEL PROGETTO?
3. QUAL É L'ESTETICA DEL PRODOTTO?

1. WHAT SOLUTION ARE YOU LOOKING FOR?
2. HOW DOES THE SOLUTION INTEGRATE INTO THE PROJECT?
3. WHAT IS THE AESTHETICS OF THE PRODUCT?

# Indice delle tipologie di soluzioni

## Index of the types of solutions

Quale soluzione cerchi? / What solution are you looking for?



**Porte battenti con cornici**  
Hinged door and frame  
P. 44



**Porte effetto filomuro**  
Flush-effect door  
P. 84



**Porte filomuro**  
Flush door  
P. 94

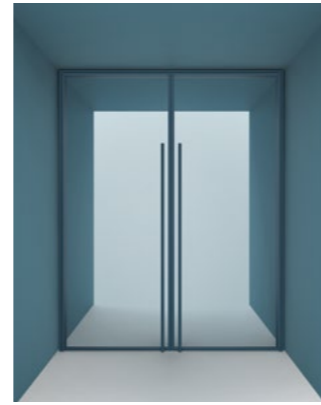

**Porte senza falso telaio**  
Door without basic door frame  
P. 142



**Cabine Armadio**  
Walk-in closet  
P. 284

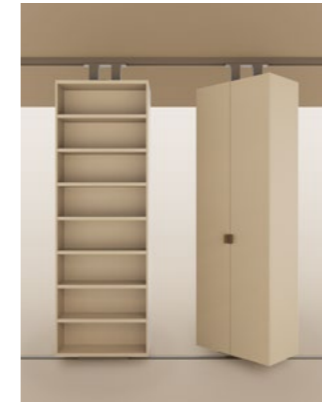

**Librerie**  
Bookcase  
P. 330



**Porte a scomparsa**  
Pocket door  
P. 184



**Pannelli scorrevoli o girevoli**  
Sliding or pivoting panel  
P. 232



**Tavoli**  
Table  
P. 340



**Pareti divisorie**  
Partition wall  
P. 262



**Boiserie**  
Boiserie  
P. 282

Informazioni generali / General informations  
 Porte battenti con cornice / Hinged door and frame  
 Porte effetto filomuro / Flush-effect door  
 Porte filomuro / Flush door  
 Porte senza falso telaio / Door w/o basic door frame  
 Porte a scomparsa / Pocket door  
 Pannelli scorrevoli o girevoli / Sliding or pivoting panels  
 Pareti divisorie / Partition wall  
 Boiserie / Boiserie  
 Cabine armadio / Walk-in closet  
 Librerie / Bookcase  
 Tavoli / Table

Informazioni generali / General informations  
 Porte battenti con cornice / Hinged door and frame  
 Porte effetto filomuro / Flush-effect door  
 Porte filomuro / Flush door  
 Porte senza falso telaio / Door w/o basic door frame  
 Porte a scomparsa / Pocket door  
 Pannelli scorrevoli o girevoli / Sliding or pivoting panels  
 Pareti divisorie / Partition wall  
 Boiserie / Boiserie  
 Cabine armadio / Walk-in closet  
 Librerie / Bookcase  
 Tavoli / Table

# Indice del Listino

## Price Book index

### Informazioni

#### 10 GUIDA RAPIDA ALL'USO

- 11 • Come comporre il prezzo?
- 12 • Come prendere le misure?

#### 20 PIÙ INFORMAZIONI

- 21 • Manuali tecnici e condizioni
- 22 • Il glossario del mondo porte

#### 30 LE NOSTRE FINITURE

- 31 • Alluminio
- 32 • Vetri traslucidi
- 34 • Vetri opachi
- 36 • Vetri con reti e tessuti
- 38 • Caratteristiche tecniche dei vetri
- 40 • Legno

### Porte e pareti divisorie

#### 44 BATTENTI CON CORNICE

- 46 • **Stipite legno per porte battenti**
- 50 - And battente con cornice
- 52 • **Stipite Morbida per porte battenti**
- 56 - Morbida battente con cornice
- 58 • **Stipite 45° per porte battenti**
- 62 • **Stipite pers. per porte battenti**
- 66 • **Stipite slim per porte battenti**
- 70 - Quadra battente con cornice
- 72 - Prima battente con cornice
- 74 - Celine battente con cornice
- 76 - Ri-trait battente con cornice
- 78 - Ri-trait 8b battente con cornice
- 80 - Ring battente con cornice
- 81 - Blow battente con cornice
- 82 - Quies battente con cornice
- 83 • **Accessori per stipiti porte battenti**

#### 84 PORTE EFFETTO FILOMURO

- 86 • **Stipite effetto filomuro**
- 88 - Level
- 90 • **Stipite bilico effetto filomuro**
- 92 - Boisé

#### 94 PORTE FILOMURO

- 96 • **Filomuro cerniere nascoste (50mm)**
- 100 - Next 50mm filomuro
- 102 • **Filomuro cerniere nascoste(58mm)**
- 106 - Next 58mm filomuro
- 108 • **Filomuro cerniere nascoste (60mm)**
- 112 • **Filomuro bilico con battuta (60mm)**
- 114 - Suit filomuro
- 116 • **Filomuro ambo lati (105 o 125mm)**
- 118 - Integra
- 120 • **Filomuro cerniera esterna (38mm)**
- 124 • **Filomuro bilico (38mm)**
- 128 - Quadra filomuro
- 130 - Prima filomuro
- 132 - Celine filomuro
- 134 - Ri-trait filomuro
- 136 - Ri-trait 8b filomuro
- 138 - Ring filomuro
- 139 - Blow filomuro
- 141 • **Accessori per porte filomuro**

#### 142 PORTE SENZA FALSO TELAIO

- 144 • **Stipite telaio singolo**
- 148 • **Stipite telaio doppio**
- 152 • **Stipite telaio bilico**
- 156 - Quadra senza falso telaio
- 158 - Prima senza falso telaio
- 160 - Celine senza falso telaio
- 162 - Ri-trait senza falso telaio
- 164 - Ri-trait 8b senza falso telaio
- 166 • **Stipite portale battente**
- 172 • **Stipite portale bilico**
- 178 - Entre-deux
- 181 • **Bilico senza stipiti**
- 182 - Next bilico senza stipiti
- 183 - Suit bilico senza stipiti

#### 184 PORTE A SCOMPARSA

- 186 • **Stipite legno per porte a scomparsa**
- 190 - And a scomparsa
- 192 • **Stipite Morbida per porte a scomparsa**
- 196 - Morbida a scomparsa
- 198 • **Stipite 45° per porte a scomparsa**
- 202 • **Stipite pers. per porte a scomparsa**
- 206 • **Stipite slim per porte a scomparsa**
- 210 • **Porte a scomparsa senza stipite**
- 214 - Quadra a scomparsa
- 216 - Prima a scomparsa
- 218 - Celine a scomparsa
- 220 - Ri-trait a scomparsa
- 222 - Ri-trait 8b a scomparsa
- 224 - Dot a scomparsa
- 226 • **Controtelai per porte a scomparsa**
- 231 • **Accessori per stipiti porte a scomp.**

#### 232 PANNELLI SCORREVOLI O GIREVOLI

- 234 • **Sistemi binario Albed**
- 236 • **Scorrevole a soffitto Evo**
- 238 • **Scorrevole a soffitto Evo+Uno**
- 240 • **Scorrevole a soffitto Uno**
- 242 • **Scorrevole a parete Evo**
- 244 • **Girevole a soffitto Evo**
- 246 - Quadra scorrevole o pivotante
- 248 - Prima scorrevole o pivotante
- 249 - Celine scorrevole o pivotante
- 250 - Ri-trait scorrevole o pivotante
- 251 - Ri-trait 8b scorrevole o pivotante
- 252 - Dot scorrevole
- 254 • **Soffietto a soffitto Evo**
- 256 - Quadra soffietto
- 257 - Ri-trait soffietto
- 258 • **Binario a parete Sail**
- 259 - Sail scorrevole
- 260 • **Binario a parete invisibile**
- 261 - And scorrevole

#### 262 PARETI DIVISORIE

- 264 • **Parete divisoria sistema continuo**
- 266 - Sistema parete divisoria All Ways
- 267 • **Struttura parete divisoria All Ways**
- 268 • **Parete divisoria sistema telaio**
- 270 - Sistema parete divisoria Quadra
- 272 - Sistema parete divisoria Prima
- 274 - Sistema parete divisoria Celine
- 276 - Sistema parete divisoria Ri-trait
- 278 - Sistema parete divisoria Ri-trait 8b
- 281 • **Struttura sistema parete telaio**

#### 282 BOISERIE

- 284 • **Boiserie a incollaggio**
- 286 - Sviluppo boiserie a incollaggio
- 288 • **Boiserie a montaggio Albed**
- 290 - Sviluppo boiserie a montaggio

### Complementi

#### 294 CABINE ARMADIO

- 296 • **Cabine armadio Ri-vista a parete**
- 296 • **Cabine armadio Ri-vole**
- 298 • **Cabina armadio Ri-vista a soffitto**
- 300 • **Cabina armadio Solo a parete**
- 302 • **Cabina armadio Solo a soffitto**
- 304 • **Cabina armadio Solo nicchia**
- 306 • **Cabina armadio Solo freestanding**
- 308 - Struttura cabina armadio
- 311 - Elementi cabina armadio
- 320 - Schienali cabina armadio
- 325 - Fianchi cabina armadio
- 326 - Ante cabina armadio
- 328 - Isole cabina armadio
- 329 - Accessori cabina armadio

#### 330 LIBRERIE

- 332 - Libreria Girevole
- 334 - Libreria Line

#### 340 TAVOLI

- 342 - Tavolo Nile

### Informations

#### 10 QUICK USER GUIDE

- 11 • How to compose the price?
- 12 • How to take the measurement?

#### 20 MORE INFORMATION

- 21 • Technical manuals and conditions
- 22 • Door glossary

#### 30 OUR FINISHING

- 31 • Aluminium
- 32 • Traslucent glass
- 34 • Opaque glass
- 36 • Glass with fabric and mesh
- 38 • Technical characteristics of glass
- 40 • Wood

### Doors and partitions wall

#### 44 HINGED DOOR AND FRAME

- 46 • **Wooden jamb for hinged door**
- 50 - And hinged door and frame
- 52 • **Morbida jamb for hinged door**
- 56 - Morbida hinged door and frame
- 58 • **Jamb 45° for hinged door**
- 62 • **Customizable jamb for hinged door**
- 66 • **Slim jamb for hinged door**
- 70 - Quadra hinged door and frame
- 72 - Prima hinged door and frame
- 74 - Celine hinged door and frame
- 76 - Ri-trait hinged door and frame
- 78 - Ri-trait 8b hinged door and frame
- 80 - Ring hinged door and frame
- 81 - Blow hinged door and frame
- 82 - Quies hinged door and frame
- 83 • **Jamb accessories for hinged door**

#### 84 FLUSH-EFFECT DOOR

- 86 - Flush-effect jamb
- 88 - Level
- 90 - Flush-effect pivoting jamb
- 92 - Boisé

#### 94 FLUSH JAMB

- 96 • **With concealed hinges (50mm)**
- 100 - Next 50mm flush door
- 102 • **With concealed hinges (58mm)**
- 106 - Next 58mm flush door
- 108 • **With concealed hinges (60mm)**
- 112 • **Pivoting flush hinged door (60mm)**
- 114 - Suit flush door
- 116 • **Flush on both sides (105 o 125mm)**
- 118 - Integra
- 120 • **With external hinge (38mm)**
- 124 • **Pivoting flush door (38mm)**
- 128 - Quadra flush door
- 130 - Prima flush door
- 132 - Celine flush door
- 134 - Ri-trait flush door
- 136 - Ri-trait 8b flush door
- 138 - Ring flush door
- 139 - Blow flush door
- 141 • **Accessories for flush doors**

#### 142 DOOR WITHOUT BASIC DOOR FRAME

- 144 • **Single frame jamb**
- 148 • **Double frame jamb**
- 152 • **Pivoting frame jamb**
- 156 - Quadra without basic door frame
- 158 - Prima without basic door frame
- 160 - Celine without basic door frame
- 162 - Ri-trait without basic door frame
- 164 - Ri-trait 8b without basic door frame
- 166 • **Hinged portal jamb**
- 172 • **Pivoting portal jamb**
- 178 - Entre-deux
- 181 • **Pivoting without jamb**
- 182 - Pivoting Next without jamb
- 183 - Pivoting Suit without jamb

#### 184 POCKET DOOR

- 186 • **Wooden jamb for pocket door**
- 190 - And pocket door
- 192 • **Morbida jamb for pocket door**
- 196 - Morbida pocket door
- 198 • **Jamb 45° for pocket door**
- 202 • **Customizable jamb for pocket door**
- 206 • **Slim jamb for pocket door**
- 210 • **Pocket door without jamb**
- 214 - Quadra pocket door
- 216 - Prima pocket door
- 218 - Celine pocket door
- 220 - Ri-trait pocket door
- 222 - Ri-trait 8b pocket door
- 224 - Dot a pocket door
- 226 • **Counterframes for pocket door**
- 231 • **Jamb accessories for pocket door**

#### 232 SLIDING OR PIVOTING PANEL

- 234 • **Albed rail system**
- 236 • **Sliding on ceiling rail Evo**
- 238 • **Sliding on ceiling rails Evo+Uno**
- 240 • **Sliding on ceiling rail Uno**
- 242 • **Sliding on wall rail Evo**
- 244 • **Pivoting on ceiling rail Evo**
- 246 - Sliding or pivoting Quadra
- 248 - Sliding or pivoting Prima
- 249 - Sliding or pivoting Celine
- 250 - Sliding or pivoting Ri-trait
- 251 - Sliding or pivoting Ri-trait 8b
- 252 - Sliding Dot
- 254 • **Folding on ceiling rail Evo**
- 256 - Folding Quadra
- 257 - Folding Ri-trait
- 258 • **Sail wall rail**
- 259 - Sliding Sail
- 260 • **Concealed wall rail**
- 261 - Sliding

#### 262 PARTITION WALL

- 264 • **Continuous system partition wall**
- 266 - All Ways partition wall system
- 267 • **All Ways partition wall structure**
- 268 • **Frame system partition wall**
- 270 - Quadra partition wall system
- 272 - Prima partition wall system
- 274 - Celine partition wall system
- 276 - Ri-trait partition wall system
- 278 - Ri-trait 8b partition wall system
- 281 • **Frame system partition wall structure**
- 282 • **BOISERIE**
- 284 • **Boiserie with gluing panels**
- 286 - Boiserie gluing development
- 288 • **Boiserie mounting Albed**
- 290 - Boiserie mounting development

### Complements

#### 294 WALK-IN CLOSET

- 296 • **Walk in closet Ri-vista on wall**
- 296 • **Walk in closet Ri-vista sliding**
- 298 • **Walk in closet Ri-vista on ceiling**
- 300 • **Walk in closet Solo on wall**
- 302 • **Walk in closet Solo on ceiling**
- 304 • **Walk in closet Solo niche**
- 306 • **Walk in closet Solo freestanding**
- 308 - Walk-in closet structure
- 311 - Walk-in closet elements
- 320 - Walk-in closet back panels
- 325 - Walk-in closet sides
- 326 - Walk-in closet doors
- 328 - Walk-in closet islands
- 329 - Walk-in closet accessories

#### 330 BOOKCASE

- 332 - Girevole bookcase
- 334 - Line bookcase

#### 340 TABLE

- 342 - Nile table

# RAPIDA GUIDA ALL'USO QUICK USER GUIDE

## Come comporre il prezzo? How to compose the price?

Segui i numeri delle tabelle / Follow the numbers in the tables

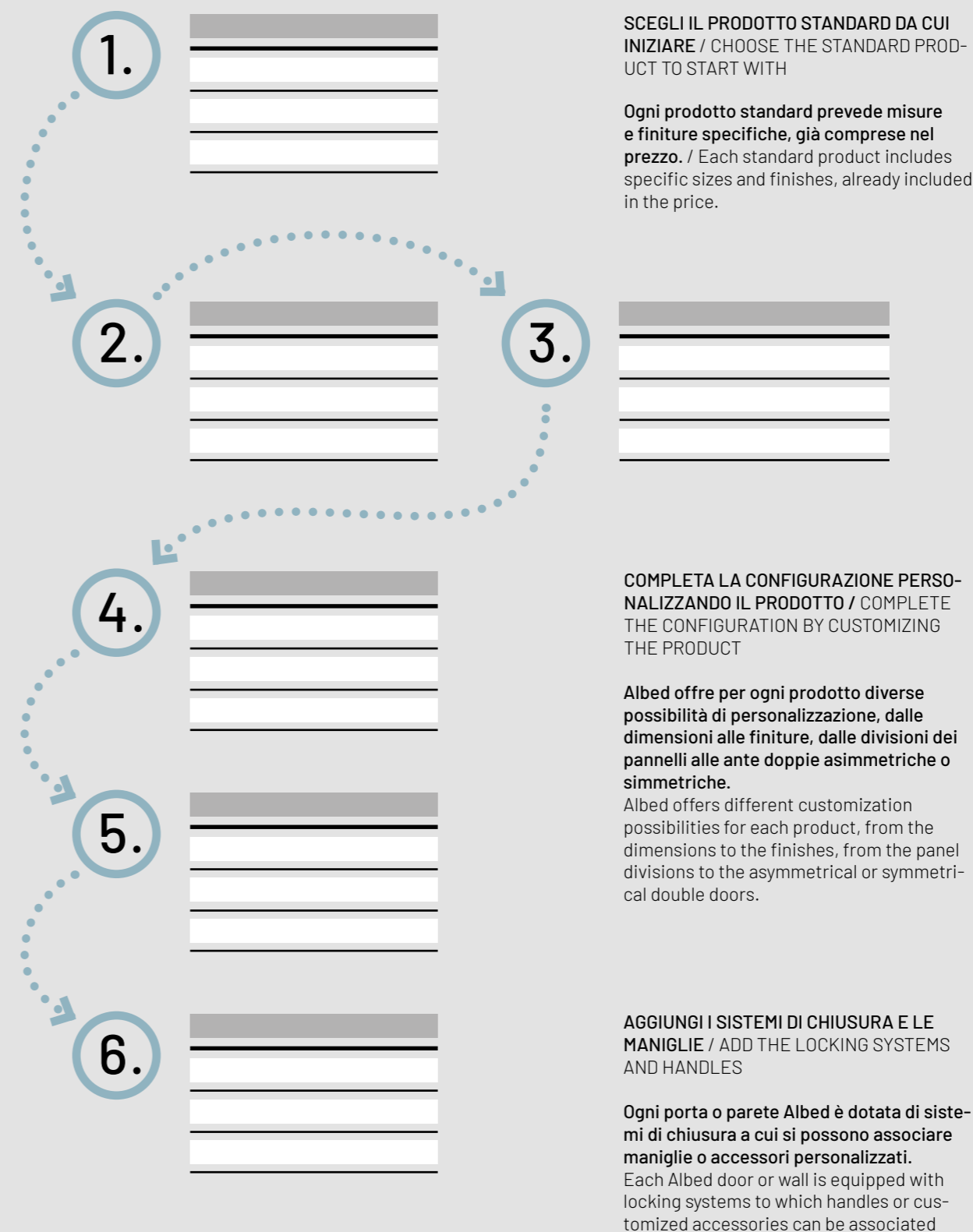

# Come prendere le misure?

## How to take the measurements?

### Le misure del mondo porte battenti e bilico

#### The hinged and pivoting doors' world measures

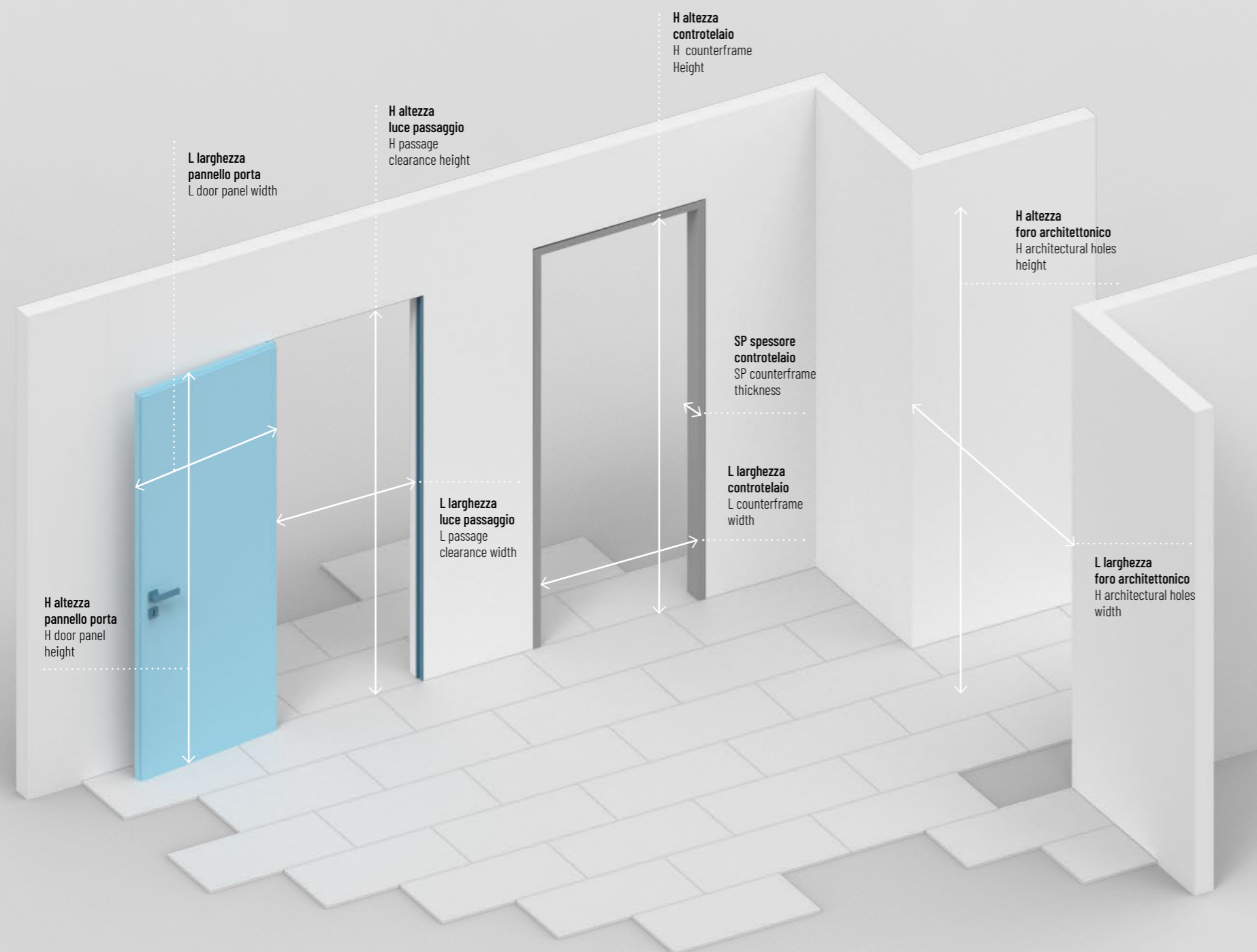

Le porte connettono due spazi, due volumi, due ambienti integrandosi col progetto architettonico e dando ritmo ai passaggi.

The doors connect two spaces, two volumes, two environments, integrating with the architectural project and giving rhythm to the passages.

Per quanto esistano misure codificate standard per le tipologie più diffuse, altre tipologie e tutte le porte su misura richiedono rilievi precisi per ottenere una corretta realizzazione.

Although there are standard codified measurements for the most door common types, other types and all custom-made doors require precise reliefs to obtain a correct realization.

Vi indichiamo la modalità corretta di rilevare le misure, necessarie in fase di ordine, in base alle diverse tipologie di chiusura.

Here are the correct way to take the measures, needed in the ordering phase, based on the different types of closure.

### Dettagli / Details

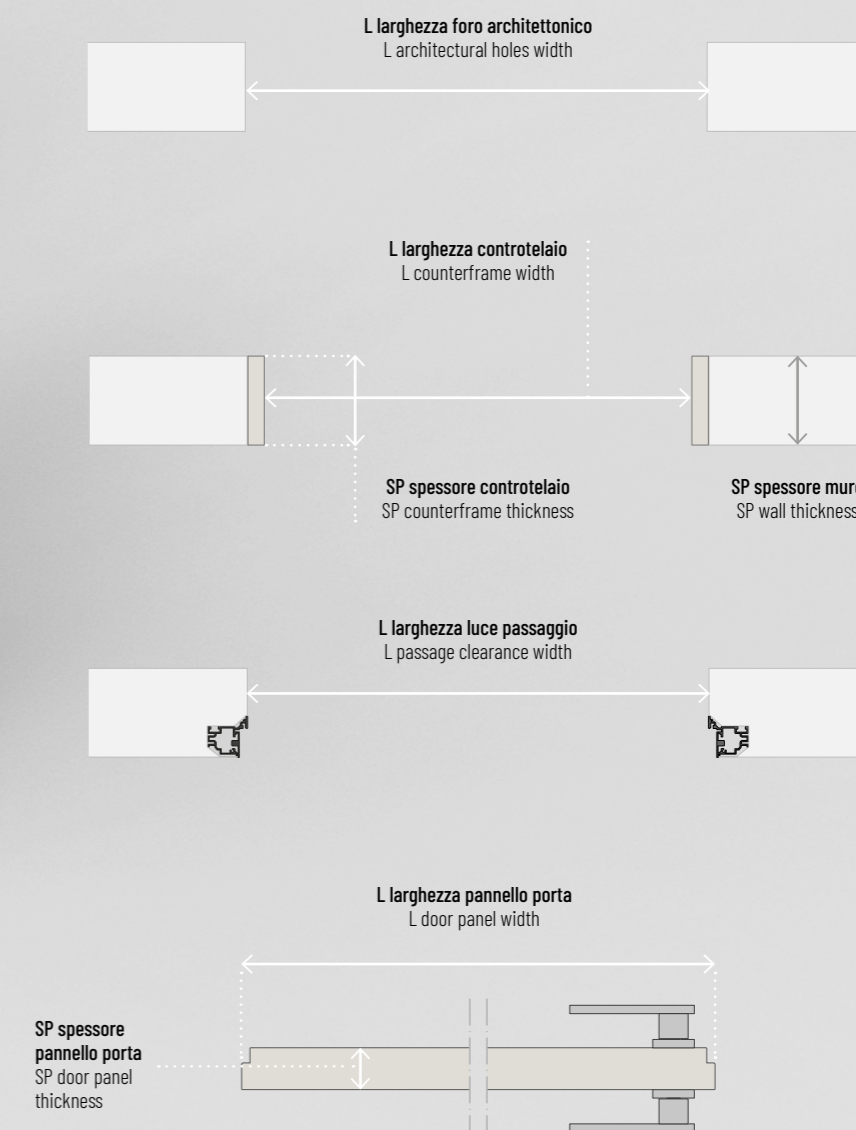

# Come prendere le misure?

## How to take the measurements?

### Le misure del mondo porte a scomparsa con stipiti

#### The world measures of pocket doors with jambs

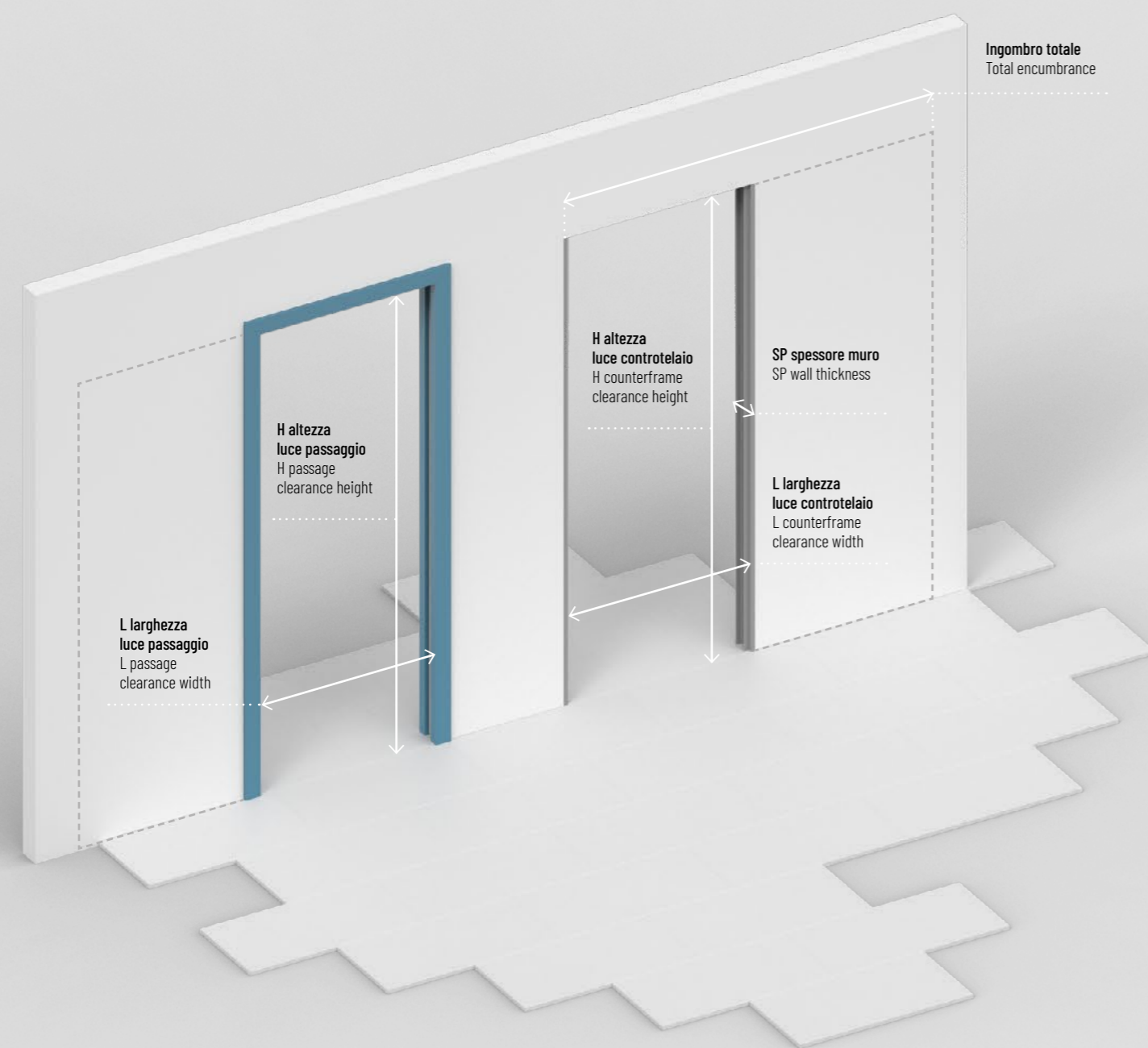

Le porte connettono due spazi, due volumi, due ambienti integrandosi col progetto architettonico e dando ritmo ai passaggi.

The doors connect two spaces, two volumes, two environments, integrating with the architectural project and giving rhythm to the passages.

Per quanto esistano misure codificate standard per le tipologie più diffuse, altre tipologie e tutte le porte su misura richiedono rilievi precisi per ottenere una corretta realizzazione.

Although there are standard codified measurements for the most door common types, other types and all custom-made doors require precise reliefs to obtain a correct realization.

Vi indichiamo la modalità corretta di rilevare le misure, necessarie in fase di ordine, in base alle diverse tipologie di chiusura.

We indicate the correct way to take the measures, necessary in the order phase, based on the different types of closure.

### Dettagli / Details

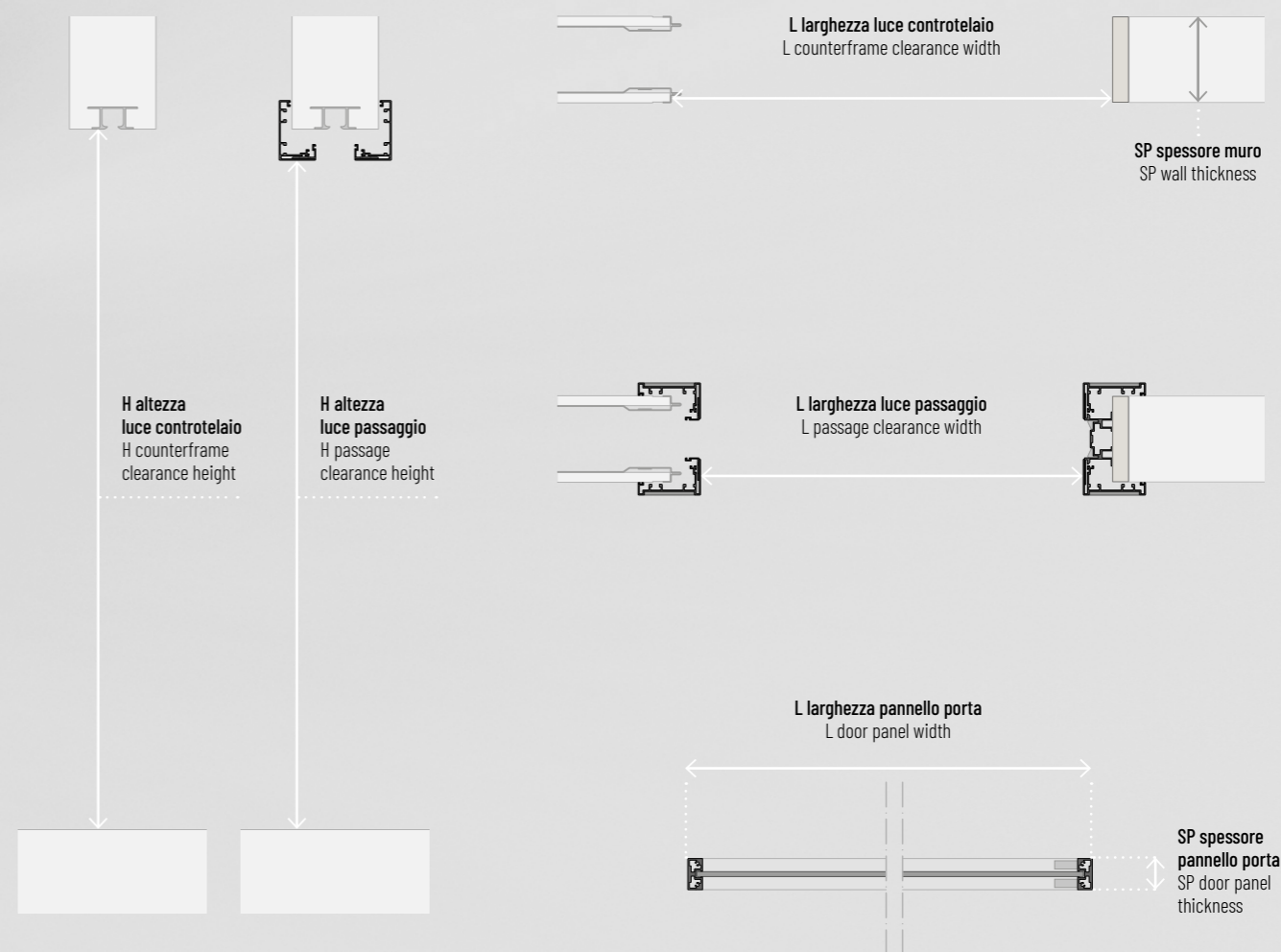



# Come prendere le misure?

## How to take the measurements?

### Le misure del mondo porte a scomparsa senza stipiti

#### The world measures of pocket doors without jambs

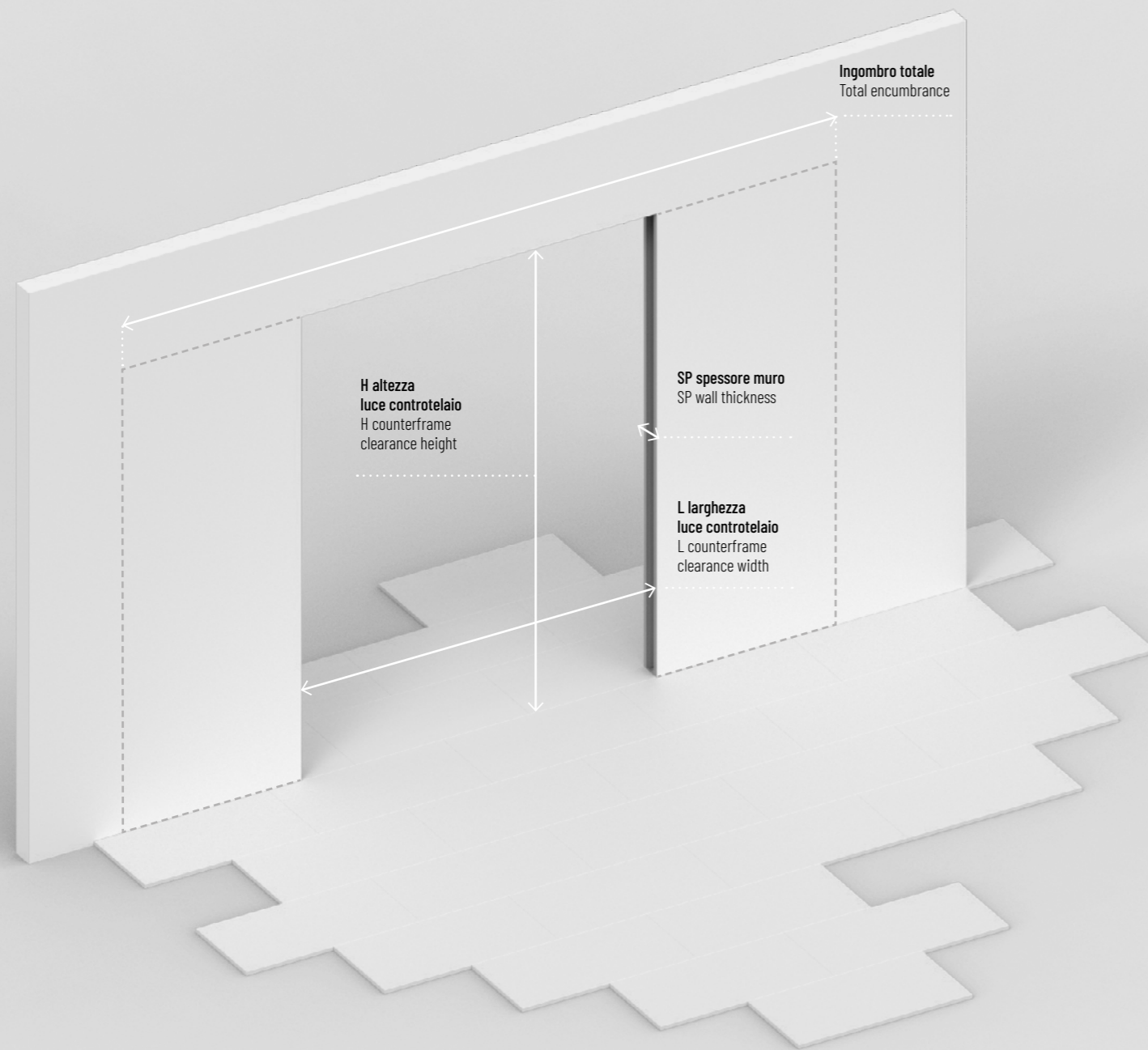

Le porte connettono due spazi, due volumi, due ambienti integrandosi col progetto architettonico e dando ritmo ai passaggi.

Per quanto esistano misure codificate standard per le tipologie più diffuse, altre tipologie e tutte le porte su misura richiedono rilievi precisi per ottenere una corretta realizzazione.

Vi indichiamo la modalità corretta di rilevare le misure, necessarie in fase di ordine, in base alle diverse tipologie di chiusura.

The doors connect two spaces, two volumes, two environments, integrating with the architectural project and giving rhythm to the passages.

Although there are standard codified measurements for the most door common types, other types and all custom-made doors require precise reliefs to obtain a correct realization.

We indicate the correct way to take the measures, necessary in the order phase, based on the different types of closure.

### Dettagli / Details

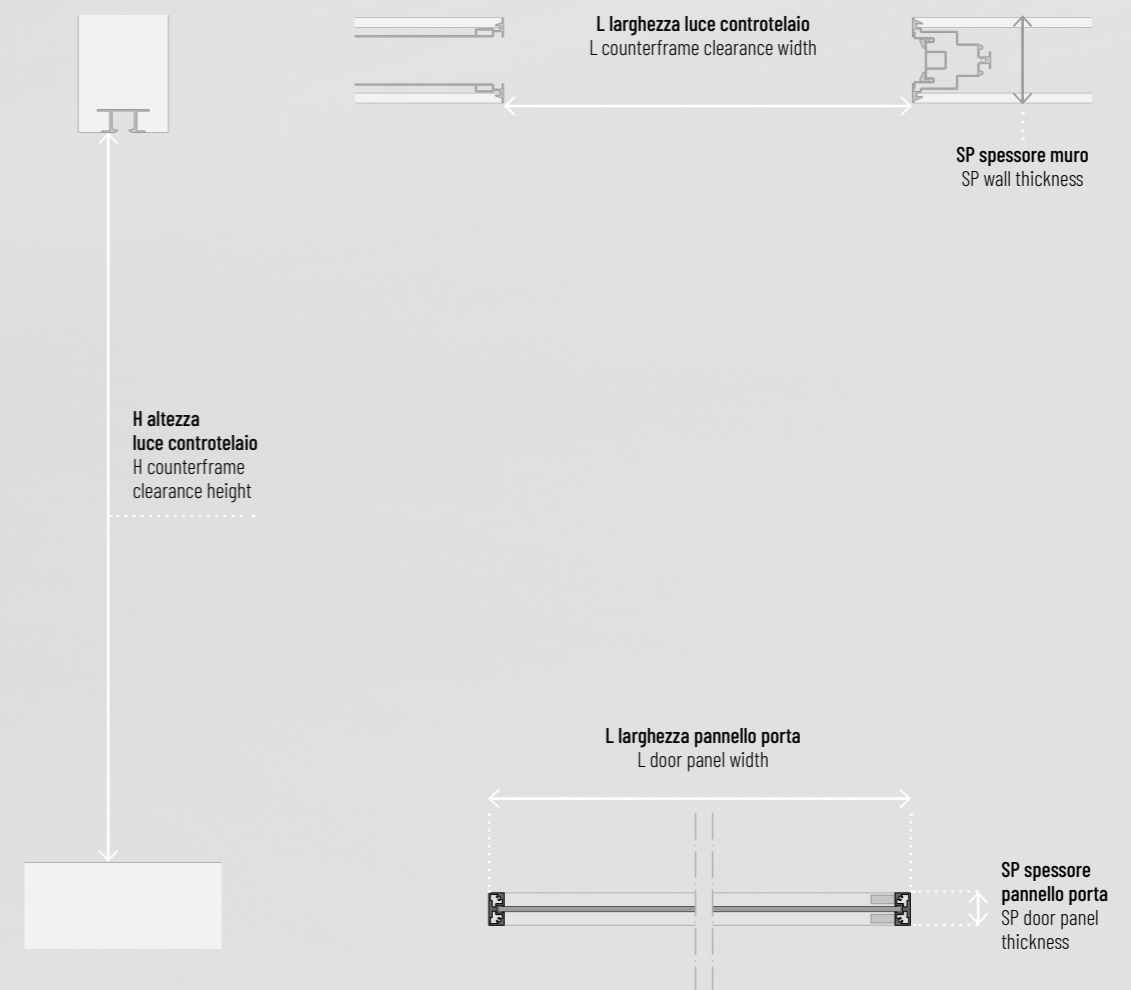

# Come prendere le misure?

## How to take the measurements?

### Le misure del mondo pannelli su binari

#### The panels' world measures

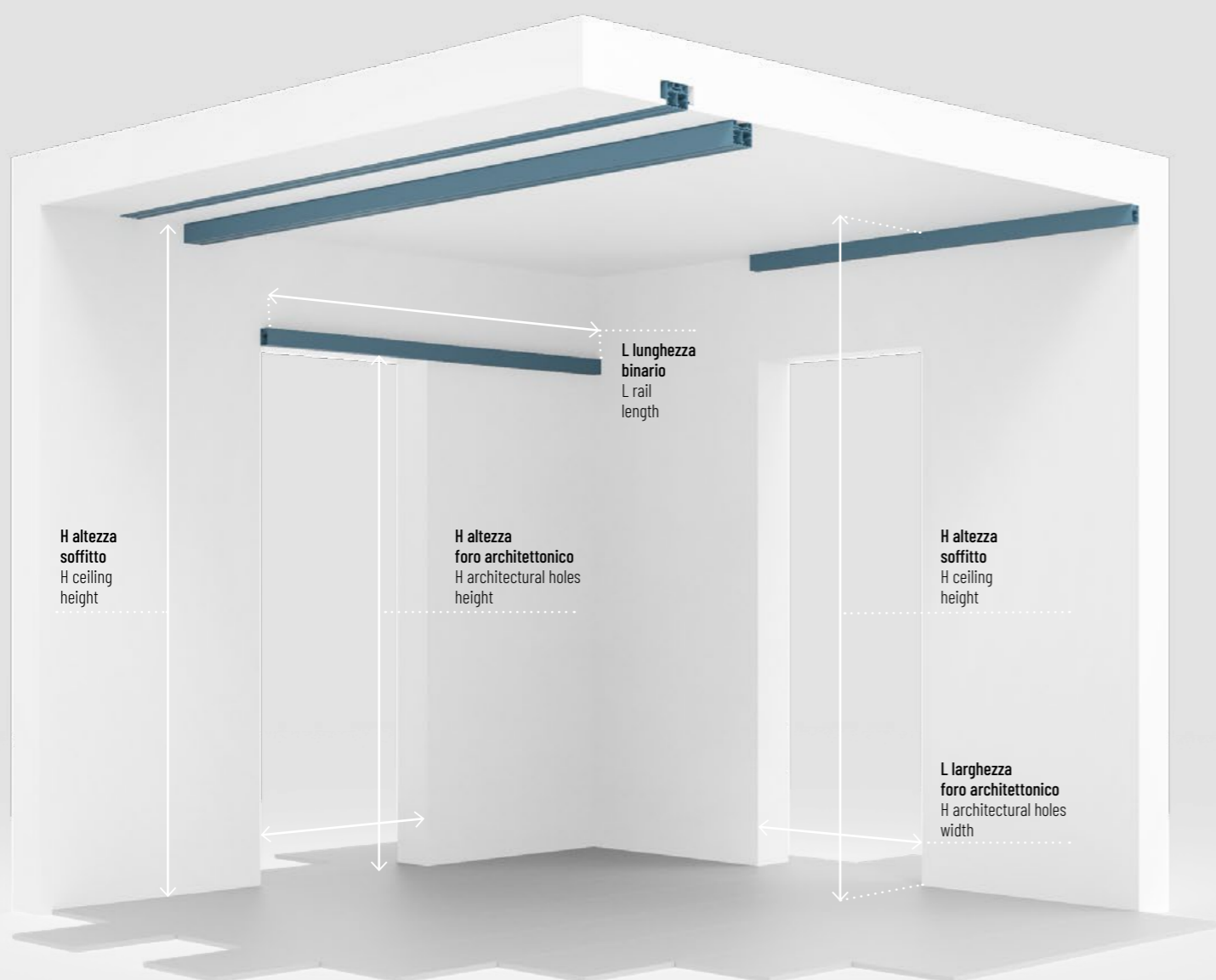

Le porte connettono due spazi, due volumi, due ambienti integrandosi col progetto architettonico e dando ritmo ai passaggi.

Per quanto esistano misure codificate standard per le tipologie più diffuse, altre tipologie e tutte le porte su misura richiedono rilievi precisi per ottenere una corretta realizzazione.

Vi indichiamo la modalità corretta di rilevare le misure, necessarie in fase di ordine, in base alle diverse tipologie di chiusura.

The doors connect two spaces, two volumes, two environments, integrating with the architectural project and giving rhythm to the passages.

Although there are standard codified measurements for the most door common types, other types and all custom-made doors require precise reliefs to obtain a correct realization.

We indicate the correct way to take the measures, necessary in the order phase, based on the different types of closure.

### Dettagli / Details

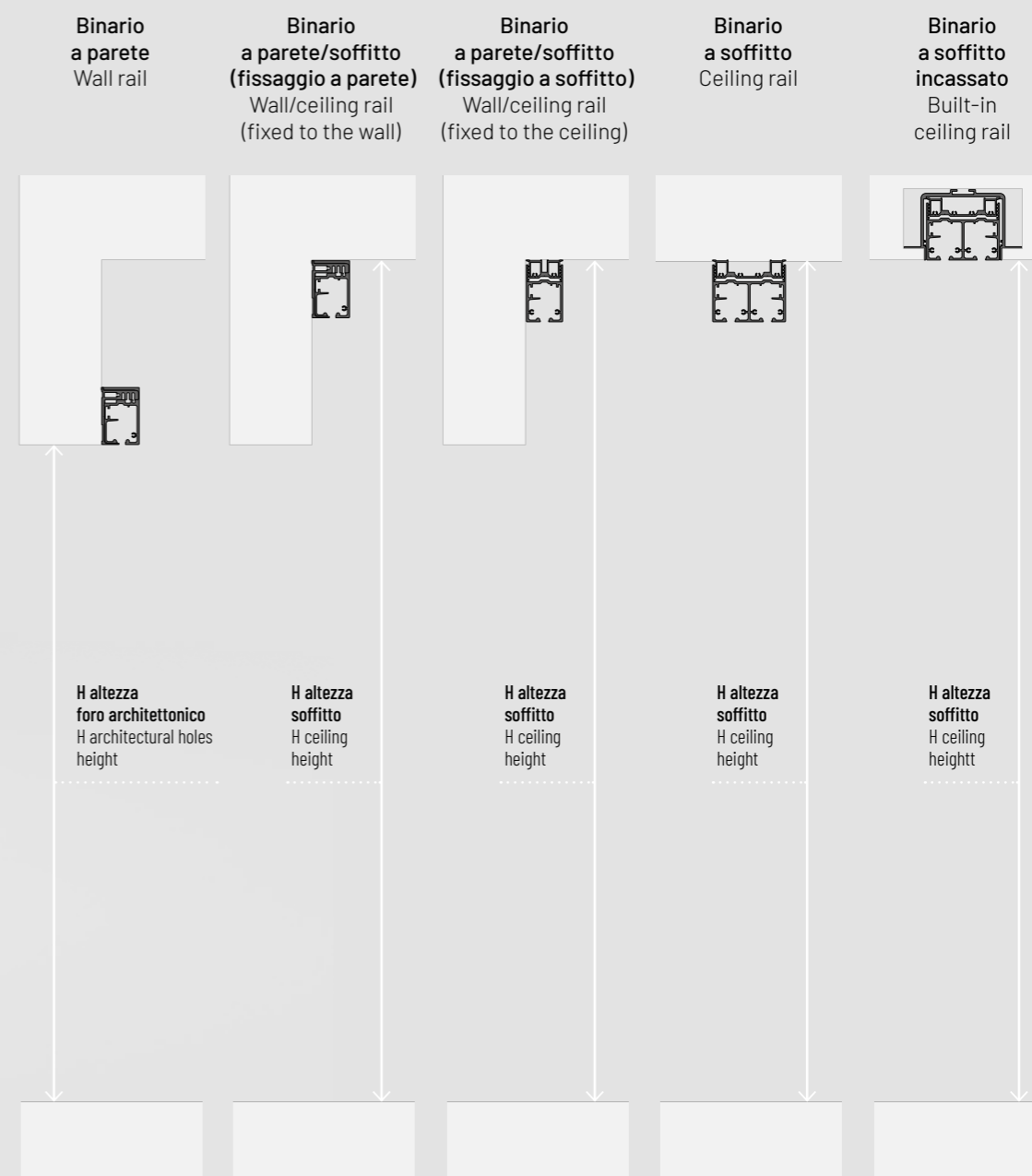

PIÙ  
INFOR-  
MAZIONI  
MORE  
INFOR-  
MATIONS

## Manuali tecnici e condizioni

### Technical manuals and conditions

#### Albed.it

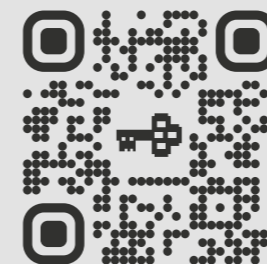

area  
riservata  
su Albed.it

reserved area  
on Albed.it

Il sito [www.albed.it](http://www.albed.it) mette a disposizione, nell'Area Riservata, una raccolta di materiali tecnici a supporto di chi sceglie le soluzioni Albed per il proprio progetto.

L' Area riservata di Albed.it è accessibile previa registrazione. La registrazione è libera e non comporta alcun costo o impegno da parte dell'utilizzatore, ma permette ad Albed di offrirvi il miglior servizio.

Qui troverete immagini, listini, e documentazione tecnica di tutti i prodotti, inclusi blocchi dwg.

Questo listino, seppur completo di informazioni dedicate a comprendere al meglio i prodotti Albed, non ha la pretesa di spiegare tutti i dettagli dei nostri prodotti. Vi invitiamo a verificare i manuali tecnici per maggiori informazioni.

The website [www.albed.it](http://www.albed.it) provides, in the Reserved Area, a collection of technical materials to support those who choose Albed solutions for their project.

The reserved area of Albed.it is accessible upon registration. Registration is free and does not involve any cost or commitment on the part of the user, but allows Albed to offer you the best service.

Here you will find images, price lists, and technical manuals of all products, including dwg blocks.

This price list, although complete with information dedicated to better understanding Albed products, does not claim to explain all the details of our products. Please check the technical manuals for more information.

#### Condizioni generali di vendita

### General Sales Conditions

A questo indirizzo potete prendere visione delle nostre condizioni generali di vendita:  
[www.albed.it/#/condizioni-general](http://www.albed.it/#/condizioni-general)

At this address you can view our general conditions of sale:  
[www.albed.it/#/condizioni-general](http://www.albed.it/#/condizioni-general)

# Il glossario del mondo porte

## Doors glossary

## Vocabolario tecnico

**AMBOLATI (PORTA FILOMURO)**

La porta filomuro ambo lati è un prodotto che Albed ha per primo introdotto nel mercato con la collezione “Integra”. Questa porta garantisce l’effetto filomuro su entrambi i lati della parete in cui è installata. Integra è disponibile per pareti con spessore 105 mm e 125 mm.

**ALLUMINIO**

L’alluminio è un metallo duttile, naturalmente di colore argenteo. E’ caratterizzato dalla sua resistenza all’ossidazione che lo rende inalterabile alla corrosione e in generale estremamente durevole. La sua possibilità di essere estruso anche in forme piuttosto complesse lo ha reso il metallo più utilizzato per la realizzazione di profili di ogni genere. (L’alluminio si lega anche con altri metalli, il che gli permette di raggiungere, nonostante la sua leggerezza, proprietà tecniche simili a quelle dell’acciaio.) La Bauxite, materiale dal quale si ricava l’alluminio, è uno degli elementi più diffusi sulla crosta terrestre. L’Alluminio ha la proprietà di essere facilmente e perpetuamente riciclato senza una sostanziale perdita delle sue proprietà. Albed utilizza alluminio estruso con lega UNI EN AW-6060 conforme alla norma UNI EN 755.

**ANODIZZATO (ALLUMINIO)**

L’anodizzazione è un processo elettrochimico mediante il quale si deposita uno strato di ossido protettivo. L’anodizzazione permette di ottenere superfici dalle finiture metalliche estremamente luminose e resistenti. Albed tratta i suoi profili in conformità alla norma UNI 10681.

**ASIMMETRICA (PORTA DOPPIA)**

Per porta doppia asimmetrica si intende una porta a doppio battente formata da un pannello di larghezza standard e da un secondo di dimensioni variabili che va a colmare la larghezza residua.

**BATTENTE (PORTA)**

La porta a battente è la tipologia di porta più diffusa. Il pannello porta è collegato allo stipite da un lato mediante cerniere che possono essere visibili oppure a scomparsa. La porta si apre facendo perno sulle cerniere e va in battuta sul lato opposto.

**BATTENTE CON CORNICE (PORTA)**

La battente con cornice è la porta tradizionale per eccellenza. È caratterizzata da uno stipite che si ancora al foro architettonico e incornicia il pannello porta.

**BATTENTE EFFETTO FILOMURO (PORTA)**

Le porte battenti ad “effetto filomuro” sono porte tradizionali che grazie a soluzioni tecniche simulano le condizioni estetiche di una porta a “filomuro”: quando il pannello porta è chiuso si posiziona in modo quasi continuo con la parete, senza stipiti visibili. Il vantaggio di una soluzione di questo tipo consiste nella semplicità di installazione, senza bisogno di ricorrere ad opere murarie o di cartongesso. Albed ha ingegnerizzato due collezioni “effetto filomuro”: “Level” e “Boisé”.

**BATTENTE FILOMURO (PORTA)**

La porta battente “filomuro” permette di ottenere una parete dalla superficie continua senza la presenza di uno stipite visibile. Quest’ultimo viene incassato all’interno della muratura o della struttura di cartongesso che lo rendono praticamente impercettibile. Le porte filomuro sono apprezzate per la loro capacità di integrarsi nel progetto architettonico, anche con rivestimenti in boiserie realizzati con diversi materiali.

**BATTENTE SENZA FALSO TELAIO (PORTA)**

Le porte senza falso telaio sono caratterizzate da uno stipite che può essere installato direttamente sulle pareti finite. Non necessitano obbligatoriamente di un foro architettonico e di conseguenza trovano la loro più frequente applicazione nella chiusura dei vani passaggio come i corridoi. Per questo motivo sono anche conosciute come “porte corridoio”.

**BOISERIE**

La boiserie è un rivestimento applicato alle pareti di un interno architettonico. Storicamente erano realizzate in legno ma possono essere sviluppate anche in vetro e in ceramica con notevoli benefici legati alle qualità intrinseche dei materiali. Albed propone due soluzioni di boiserie con pannelli in aderenza alla parete e pannelli ispezionabili.

**CERNIERA**

La cerniera è quel meccanismo che permette l’apertura di una porta. Diversi tipi di cerniera permettono di ottenere effetti estetici e angoli di apertura differenti. Albed utilizza cerniere a scomparsa (completamente invisibili quando la porta è chiusa), e cerniere esterne.

**COPRIFILI**

I coprifili sono elementi di finitura che rifiniscono e completano la giunzione tra il telaio dello stipite e il falso telaio. I coprifili sono presenti tipicamente nelle soluzioni “a battente” e “a scomparsa”, mentre sono assenti nelle porte “filomuro”.

**CONTRO TELAIO**

Il contro telaio (chiamato anche “falso-telaio”) è un telaio in legno grezzo che viene installato lungo il perimetro dei fori architettonici permettendo l’installazione di alcune tipologie di porte. Sul contro telaio viene fissato il telaio dello stipite. In fase di progettazione è importante rilevare le esatte dimensioni del contro telaio e verificare che i coprifili della porta, una volta installati, saranno idonei a nascondere il falso telaio.

**CUOIO**

Il cuoio è un materiale che si ricava dalla lavorazione della pelle di alcuni animali. In alcuni casi viene utilizzato cuoio rigenerato che viene prodotto lavorando scarti di confezionamento, residui conciari e finitura di manufatti in cuoio. Questa soluzione permette di raggiungere dimensioni maggiori con superfici continue.

**DESTRA (PORTA)**

La porta viene definita destra quando le cerniere si trovano alla destra del pannello porta. Le porte Albed sono disponibili sia con cerniere a destra che con cerniere a sinistra, con apertura a tirare oppure a spingere.

**DIGITAL (VETRO)**

Il vetro “digital” è un particolare vetro selezionato da Albed dopo anni di ricerca che permette di installare monitor dietro alla sua superficie in modo che questo risulti completamente invisibile, garantendo però la trasparenza dell’immagine riprodotta. Il vetro “digital” è disponibile per il prodotto Integra Vision (porta filomuro ambo lati con monitor integrato).

**ALUMINUM**

Aluminum is a ductile metal, naturally silvery in color. It is characterized by its resistance to oxidation which makes it unalterable to corrosion and in general extremely durable. Its ability to be extruded even in rather complex shapes has made it the most used metal for the creation of profiles of all kinds. Bauxite, the material from which aluminum is obtained, is one of the most widespread on the earth’s crust. Aluminum has the feature of being easily and perpetually recycled without a substantial loss of its properties. Albed uses extruded aluminum with UNI EN AW-6060 alloy compliant with the UNI EN 755 standard.

**ANODIZED (ALUMINUM)**

Anodizing is an electrochemical process by which a protective oxide layer is deposited. Anodizing makes it possible to obtain surfaces with extremely bright and resistant metallic finishes. Albed treats its profiles in compliance with the UNI 10681 standard.

**ARCHITECTURAL HOLE**

The architectural hole is the passage in the wall that allows the connection between two environments. It is normally prepared for the installation of doors with the appropriate counter frame.

**ASYMMETRIC (DOUBLE DOOR)**

By asymmetrical double door we mean a double hinged door made up of a panel of standard width and a second one of variable dimensions that fills the residual width.

**BACK PAINTED (GLASS)**

By “back-lacquered” glass we mean glass painted on the side which is behind. In this way it is possible to obtain opaque (non-transparent) surfaces of great brightness and depth, generated by the combination of the glossy surface of the glass and the depth of the painted surface. The back side of the glass cannot be cleaned with aggressive chemicals, which could damage it.

**BACK PANEL**

Backs are special panels that close the space among the uprights of the walk-in closets, covering the wall. They can be in glass or wood, in all available finishings.

**BOISERIE**

The boiserie is a covering system applied to the walls of an architectural interior. Historically they were made of wood but can also be developed in glass and ceramic with considerable benefits linked to the intrinsic qualities of the materials. Albed offers two boiserie solutions with panels adhering to the wall and inspectable panels.

**ON BOTH SIDES (FLUSH DOOR)**

The flush door on both sides is a product that Albed was the first to introduce on the market with the “Integra” collection. This door guarantee the flush effect on both sides of the wall where it’s installed. Integra is available for wall with a thikness of 105mm and 125mm.

**CASINGS**

The casings are the finishing elements that finish and complete the junction between the frame of the jamb and the false frame. The casing are typically used in the “hinged” and “pocket” solutions, while they are absent in the flush with the wall doors.

**CLOSING SYSTEM**

The “closing system” defines the closing modality in the closed position. In some cases it can provide for the the use of a lock while, in other cases, Albed proposes magnetic solutions or solutions with “smart” hinges.

**COUNTER FRAME**

The counter frame (also called “false-frame”) is a raw wood frame that is installed along the perimeter of the architectural holes allowing the installation of some types of doors. The frame of the jamb is fixed to the counter frame. During the design phase it is important to detect the exact dimensions of the counter frame and verify that the door casings, once installed, will be suitable for hiding the counter frame.

**CUSTOM RAL VARNISHED**

Albed offers the possibility to its customers to create customized paints. There are normalized colour scales, such as RAL table, which allow the customer to choose and communicate the desired finishing in an univocal way.

**DIGITAL (GLASS)**

The “digital” glass it’s a particular glass selected by Albed after years of research, that permits to install a monitor behind its surface, in a way that makes it invisible.

**DOOR COMPARTMENT**

The door compartment generally indicates the hole where the door is installed. In taking measurements, it is important to specify in detail what is being considered, with more precise information such as: the architectural hole (it considers only the hole in the wall), the basic door frame (it is the space that results vertically from the distance between the finished floor level and the upper side of the counter-frame and horizontally from the distance between the two vertical prifiles of the same) or the passage clearance (it is the space that results from the installation of the jambs).

**DOUBLE (GLASS)**

Some collections offer the solution with the “double glass” panel. In this case, the panel consists of an aluminum perimeter frame that houses 2 glass surfaces (one on the front and one on the back), creating a sort of glass honeycomb.

**FINISHINGS**

The finishings are treatments to which the materials are subjected in order to obtain a certain aesthetic effect. Albed offers a wide range of finishes in aluminum, glass, wood, leather and different types of lacquering.

**FLUSH EFFECT HINGED DOOR**

The flush effect hinged doors are traditional doors that, thank ti technical solutions, simulate the aesthetic conditions of a flush door: when the door panel is closed, it is positioned almost continuously with the wall, without visible jambs. The advantage of this solution consists in the simplicity of installation, without the need for masonry or plasterboard works. Albed has engineered two “flush effect” collections: “Level” and “Boisé”.





**TRAVERSINI**

I traversini sono dei profili in alluminio che, nelle porte in alluminio e vetro, permettono di realizzare specchiature multiple. In alcuni casi dividono effettivamente il pannello di vetro permettendo così l'inserimento di diverse finiture, mentre in altri casi hanno una funzione prettamente estetica, essendo solo applicati al pannello in vetro.

**VANO PORTA**

Il vano porta indica genericamente il foro dove viene installata una porta. Nel prendere le misure è bene specificare più nel dettaglio cosa si sta prendendo in considerazione, con indicazioni più puntuali come: foro architettonico (considera il solo foro nella parete), falso telaio (il vano che risulta verticalmente dalla distanza tra il filo finito del pavimento e il traverso superiore del controtelaio e orizzontalmente dalla distanza tra i due montanti verticali dello stesso) o il passaggio porta (il vano che risulta dall'installazione degli stipiti).

**VERNICIATO (ALLUMINIO)**

La verniciatura è un trattamento di finitura dell'alluminio e può avvenire mediante polveri speciali o vernici liquide. Per i propri prodotti, Albed utilizza verniciature a polveri conformi alla norma UNI 12206 oppure laccature con vernici all'acqua.

**VERNICIATO CUSTOM RAL**

Albed rende disponibile ai propri clienti la possibilità di realizzare verniciature customizzate. Esistono scale di colori normalizzate, come la tabella RAL, che permettono la scelta e la comunicazione della finitura desiderata in modo univoco.

**VETRO**

Materiale costituito da silicati, in genere di metalli alcalini, alcalino-terrosi e di altri metalli bivalenti, ottenuto per fusione di sabbia silicea con ossidi e carbonati, avente consistenza solida ma natura amorfa, di larghissimo impiego in numerose applicazioni per la sua proprietà di essere modellato nelle più svariate forme e per la sua trasparenza. Albed propone una delle più vaste collezioni di porte e partizioni di interni in alluminio e vetro e oggi vanta di un catalogo di più di 56 finiture del vetro. Albed utilizza solo vetro di sicurezza secondo lo standard UNI EN 12150 e UNI EN ISO 12543.

**YALE (CHIAVE)**

La Yale è una chiave a corpo piatto, con fori calibrati. Questa chiave è stata brevettata nel 1861 da Linus Yale Jr, a cui deve il proprio nome. Garantisce un livello di sicurezza superiore alla chiave Patent.

**WOODEN HONEYCOMB (PANEL)**

The wooden honeycomb is a panel used in the production of furniture and furnishings, particularly appreciated for its lightness. The wooden honeycomb consists of two sheets of MDF (a high-density industrial technical wood panel) called covers, glued on a wooden frame. Usually a panel of alveolar paper is placed inside the panel in order to increase the rigidity. Albed uses honeycomb panels made in Italy to its own specifications and with the best materials. In some cases, in order to improve the acoustic performance or the the fire resistance, as in the case of the flush door "Next Ei30", panels of specific materials are used inside the wooden honeycomb panel.

**YALE (KEY)**

The Yale key is a flat-bodied key with calibrated holes. This key was patented in 1861 by Linus Yale Jr, to whom it owes its name. It ensures an higher level of security respect the Patent key.



# LE NOSTRE FINITURE OUR FINISH- INGS

## Alluminio Aluminium

### Finitura alluminio anodizzato / Anodized aluminium finishing

Nero	AN	Titanio	AT	Alluminio	AA	Champagne	AC	Oro	AG	Bronzo	AB
Alluminio anodizzato Anodized Aluminium		Alluminio laccato metallizzato Metallic lacquered aluminium		Alluminio anodizzato Anodized Aluminium		Alluminio anodizzato Anodized Aluminium		Alluminio laccato metallizzato Metallic lacquered aluminium		Alluminio anodizzato Anodized Aluminium	

### Finitura alluminio verniciato / Painted aluminium finishing

Bianco Ral 9003	AI	Custom Ral	AR
Alluminio verniciato epossidico Epoxy painted aluminium		Alluminio laccato Lacquered aluminium	

### Compatibilità / Compatibilities

Tipologia Typology	Nome finitura Finishing name	Codice Code	Prima	Quadra	Celine	Ri-trait	Ri-trait 8b	Integra	Next	Suit	Entre-deux	Dot	Sail	Oues	And	Morbida	Ring	Blow	Level	Boisé	All Ways	Boiserie	Solo/Ri-vista	Girevole	Nile
			Finiture alluminio anodizzato Anodized aluminium finishings	Nero	AN	●	●	●	●	●	●	●	●	●	●	●	●	●	●	●	●	●	●	●	●
Titanio	AT	●		●	●	●	●	●	●	●	●	●	●	●	●	●	●	●	●	●	●	●	●	●	●
Alluminio	AA	●		●	●	●	●	●	●	●	●	●	●	●	●	●	●	●	●	●	●	●	●	●	●
Champagne	AC	●		●	●	●	●	●	●	●	●	●	●	●	●	●	●	●	●	●	●	●	●	●	●
Oro	AG	●		●	●	●	●	●	●	●	●	●	●	●	●	●	●	●	●	●	●	●	●	●	●
Bronzo	AB	●		●	●	●	●	●	●	●	●	●	●	●	●	●	●	●	●	●	●	●	●	●	●
Alluminio Verniciato Painted aluminium	Bianco Ral 9003	AI	●	●	●	●	●	●	●	●	●	●	●	●	●	●	●	●	●	●	●	●	●	●	●
	Custom Ral	AR						●	●							●			●					●	

Informazioni generali / General informations  
 Porte battenti con cornice / Hinged door and frame  
 Porte effetto filomuro / Flush-effect door  
 Porte filomuro / Flush door  
 Porte senza falso telaio / Door w/o basic door frame  
 Porte a scomparsa / Pocket door  
 Pan. scorrevoli o girevoli / Sliding or pivoting panels  
 Pareti divisorie / Partition wall  
 Boiserie / Boiserie  
 Cabine armadio / Walk-in closet  
 Librerie / Bookcase  
 Tavoli / Table

Informazioni generali / General informations  
 Porte battenti con cornice / Hinged door and frame  
 Porte effetto filomuro / Flush-effect door  
 Porte filomuro / Flush door  
 Porte senza falso telaio / Door w/o basic door frame  
 Porte a scomparsa / Pocket door  
 Pan. scorrevoli o girevoli / Sliding or pivoting panels  
 Pareti divisorie / Partition wall  
 Boiserie / Boiserie  
 Cabine armadio / Walk-in closet  
 Librerie / Bookcase  
 Tavoli / Table



# Vetri traslucidi

## Traslucent Glass

### Trasparenti / Transparent

Neutro 10    Trasparente 1C    Neutro Extrachiaro 64    Bronzo 17    Fumé 15    Dark Gray 63

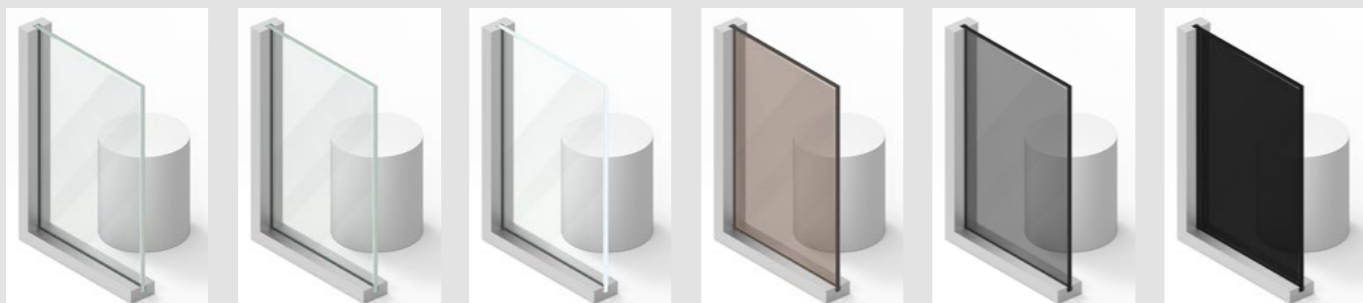

<b>Categoria / Category:</b> A	<b>Categoria / Category:</b> -	<b>Categoria / Category:</b> B	<b>Categoria / Category:</b> A	<b>Categoria / Category:</b> A	<b>Categoria / Category:</b> B
<b>Spessore / Thickness:</b> • <b>Temperato / Tempered</b> 4   6   8 mm • <b>Stratificato / Laminated</b> 3+3   5+5   6+6 mm	<b>Spessore / Thickness:</b> • <b>Temperato / Tempered</b> 10   12 mm • <b>Stratificato / Laminated</b> -	<b>Spessore / Thickness:</b> • <b>Temperato / Tempered</b> 4   6   8 mm • <b>Stratificato / Laminated</b> 3+3   5+5   6+6 mm	<b>Spessore / Thickness:</b> • <b>Temperato / Tempered</b> 4   6   8 mm • <b>Stratificato / Laminated</b> 6+4   6+6 mm	<b>Spessore / Thickness:</b> • <b>Temperato / Tempered</b> 4   6   8 mm • <b>Stratificato / Laminated</b> 6+4   6+6 mm	<b>Spessore / Thickness:</b> • <b>Temperato / Tempered</b> 4   6   8 mm • <b>Stratificato / Laminated</b> 6+4   6+6 mm

### Semi-trasparenti / Semi-transparent

Acidato 11    Satinato 1D    Acidato Extrachiaro 65    Bianco Latte 12    Bronzo Acidato 18    Fumé Acidato 16

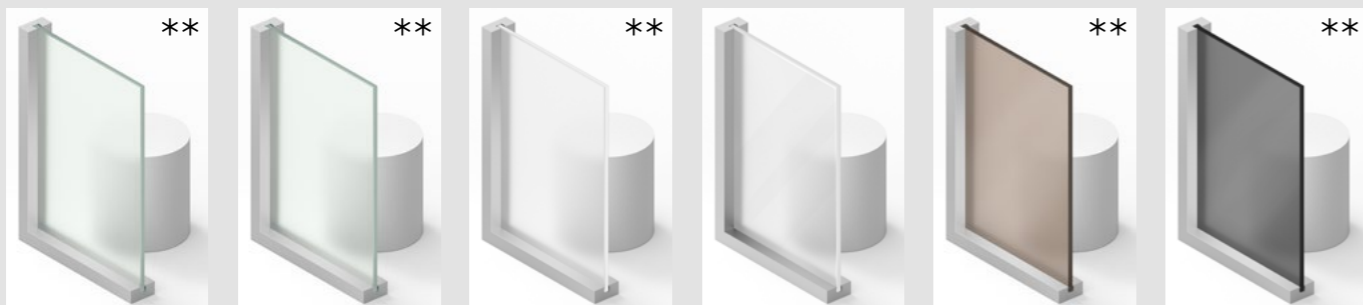

<b>Categoria / Category:</b> A	<b>Categoria / Category:</b> A	<b>Categoria / Category:</b> C	<b>Categoria / Category:</b> A	<b>Categoria / Category:</b> B	<b>Categoria / Category:</b> B
<b>Spessore / Thickness:</b> • <b>Temperato / Tempered</b> 4   6   8 mm • <b>Stratificato / Laminated</b> 3+3   5+5   6+6 mm	<b>Spessore / Thickness:</b> • <b>Temperato / Tempered</b> 10   12 mm • <b>Stratificato / Laminated</b> -	<b>Spessore / Thickness:</b> • <b>Temperato / Tempered</b> 4   6   8 mm • <b>Stratificato / Laminated</b> 3+3   5+5   6+6 mm	<b>Spessore / Thickness:</b> • <b>Temperato / Tempered</b> -	<b>Spessore / Thickness:</b> • <b>Temperato / Tempered</b> 4   6   8 mm • <b>Stratificato / Laminated</b> 6+4   6+6 mm	<b>Spessore / Thickness:</b> • <b>Temperato / Tempered</b> 4   6   8 mm • <b>Stratificato / Laminated</b> 6+4   6+6 mm

### Riflettenti / Reflective

Neutro Reflex 94    Bronze Reflex 93    Smoked Reflex 92    Gold Reflex 7A

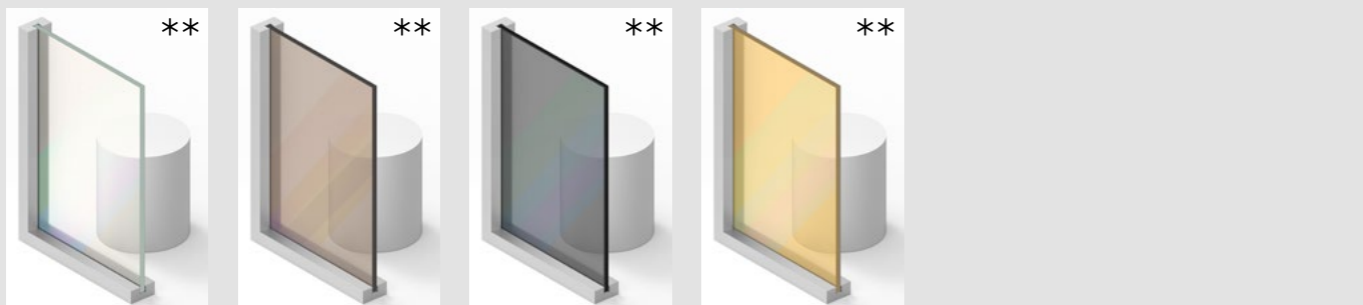

<b>Categoria / Category:</b> C	<b>Categoria / Category:</b> C	<b>Categoria / Category:</b> C	<b>Categoria / Category:</b> C
<b>Spessore / Thickness:</b> • <b>Temperato / Tempered</b> 4   6   8 mm • <b>Stratificato / Laminated</b> 6+4   6+6 mm	<b>Spessore / Thickness:</b> • <b>Temperato / Tempered</b> 4   6   8 mm • <b>Stratificato / Laminated</b> 6+4   6+6 mm	<b>Spessore / Thickness:</b> • <b>Temperato / Tempered</b> 4   6   8 mm • <b>Stratificato / Laminated</b> 6+4   6+6 mm	<b>Spessore / Thickness:</b> • <b>Temperato / Tempered</b> 6 mm • <b>Stratificato / Laminated</b> -

### Materici / Textured

Gothic 87    Shanghai Verticale 96    Shanghai Orizzontale 95    Plissé 6B    Rec 88    Cube 7C

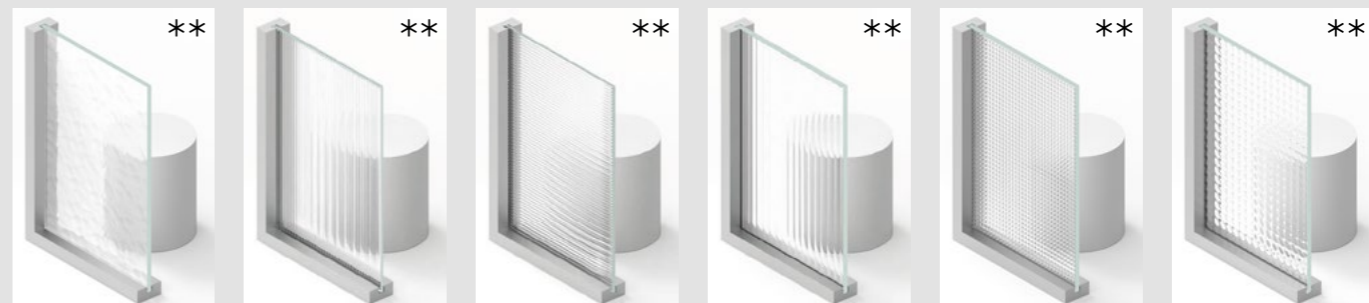

<b>Categoria / Category:</b> D	<b>Categoria / Category:</b> D	<b>Categoria / Category:</b> D	<b>Categoria / Category:</b> C	<b>Categoria / Category:</b> D	<b>Categoria / Category:</b> D
<b>Spessore / Thickness:</b> • <b>Stratificato / Laminated</b> 4+4   4+6   6+6 mm	<b>Spessore / Thickness:</b> • <b>Temperato / Tempered</b> 4   6 mm • <b>Stratificato / Laminated</b> 4+4   4+6   6+6 mm	<b>Spessore / Thickness:</b> • <b>Temperato / Tempered</b> 4   6 mm • <b>Stratificato / Laminated</b> 4+4   4+6   6+6 mm	<b>Spessore / Thickness:</b> • <b>Temperato / Tempered</b> 4   6 mm • <b>Stratificato / Laminated</b> 4+4   4+6   6+6 mm	<b>Spessore / Thickness:</b> • <b>Temperato / Tempered</b> 4   6 mm • <b>Stratificato / Laminated</b> 4+4   4+6   6+6 mm	<b>Spessore / Thickness:</b> • <b>Temperato / Tempered</b> 4   6 mm • <b>Stratificato / Laminated</b> 4+4   4+6   6+6 mm

### Compatibilità / Compatibilities

Tipologia Typology	Nome finitura Finishing name	Codice Code	Categoria Category																						
				Prima	Quadra	Celine	Ri-trait	Ri-trait 8b	Integra	Next	Suit	Entre-deux	Dot	Sail	Quies	And	Morbida	Ring	Blow	Level	Boisé	All Ways	Boiserie	Solo/RI+vista	Girevole
Vetri traslucidi trasparenti Transparent translucent glass	Neutro	10	A	●	●	●	●	●																	
	Trasparente	1C	-																			●			
	Neutro Extrachiaro	64	B	●	●	●	●	●														●			
	Bronzo	17	A	●	●	●	●	●														●			●
	Fumé	15	A	●	●	●	●	●														●			●
	Dark Gray	63	B	●	●	●	●	●														●			●
Vetri traslucidi semi-trasparenti Semi-transparent translucent glass	Acidato**	11	A	●	●	●	●	●																●	
	Satinato**	1D	A																					●	
	Acidato Extrachiaro**	65	C	●	●	●	●	●																●	
	Bianco Latte	12	A	●	●	●	●	●																●	
Vetri traslucidi riflettenti Reflective translucent glass	Bronzo Acidato**	18	B	●	●	●	●	●																●	
	Fumé Acidato**	16	B	●	●	●	●	●																●	
	Neutro Reflex**	94	C	●	●	●	●	●																●	
	Bronze Reflex**	93	C	●	●	●	●	●																●	
Vetri traslucidi materici Textured translucent glass	Smoked Reflex**	92	C	●	●	●	●	●																●	
	Gold Reflex**	7A	C	●	●	●	●	●																●	
	Gothic**	87	D																					●	
	Shanghai verticale**	96	D																					●	
Vetri traslucidi materici Textured translucent glass	Shanghai orizzontale**	95	D																					●	
	Plissé**	6B	C	●	●	●	●	●																●	
	Rec**	88	D	●	●	●	●	●																●	
	Cube**	7C	D	●	●	●	●	●																●	

\*non disponibile per Quadra doppio vetro e Quadra soffiato vetro singolo  
\*not available for Quadra double glass and Folding Quadra single glass

\*\* Per questi vetri la lavorazione superficiale che li caratterizza (acidatura, riflettanza, tridimensionalità) viene effettuata su una sola delle due facce del vetro. Al momento dell'ordine è necessario indicare la faccia su cui deve trovarsi questa lavorazione superficiale: fronte o retro. Attenzione: se non specificato, si intenderà fronte lucido per i vetri acidati (semi-trasparenti), fronte riflettente per i vetri riflettenti e fronte tridimensionale per i vetri tridimensionali (materici).  
\*\* For these glasses the surface processing that characterizes them (acid etching, reflectance, three-dimensionality) is carried out on only one of the two faces of the glass. At the time of the order it is necessary to indicate the face on which this surface processing must be located: front or back. Attention: if not specified, it will be ment glossy front for the etched glasses (semi-transparent), reflective front for reflective glasses and tridimensional front for tridimensional glasses (textured)

# Vetri opachi

## Opaque glass

### Laccati / Laquered

Neve extrachiaro 53    Neve Acidato extrachiaro 51    Polvere 72    Polvere Satinato 74    Sabbia 9A    Sabbia Satinato 3B

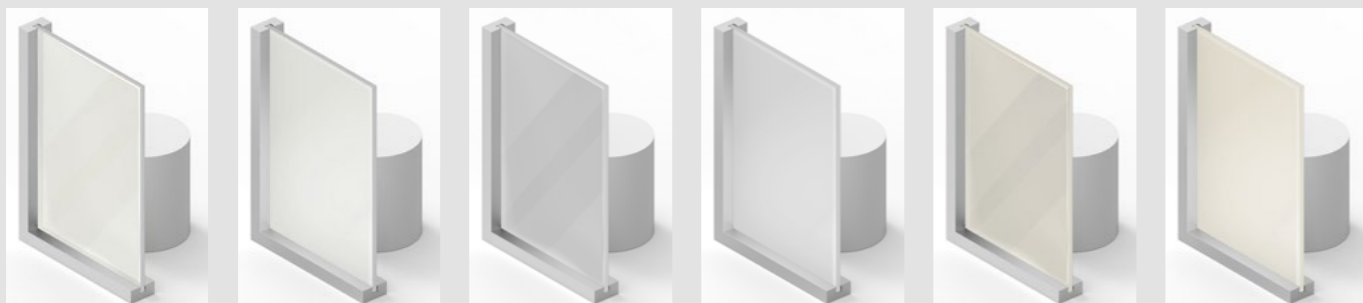

**Categoria / Category:** D    **Categoria / Category:** D    **Categoria / Category:** D    **Categoria / Category:** D    **Categoria / Category:** C    **Categoria / Category:** D

**Spessore / Thickness:**  
 • **Temperato / Tempered** 4 mm\*  
 • **Stratificato / Laminated** 3+3 | 5+5 | 6+6 mm

Tortora 38    Tortora Satinato 67    Cenere 4A    Cenere Satinato 5A    Grigio Londra 1B    Grigio Londra Satinato 4B

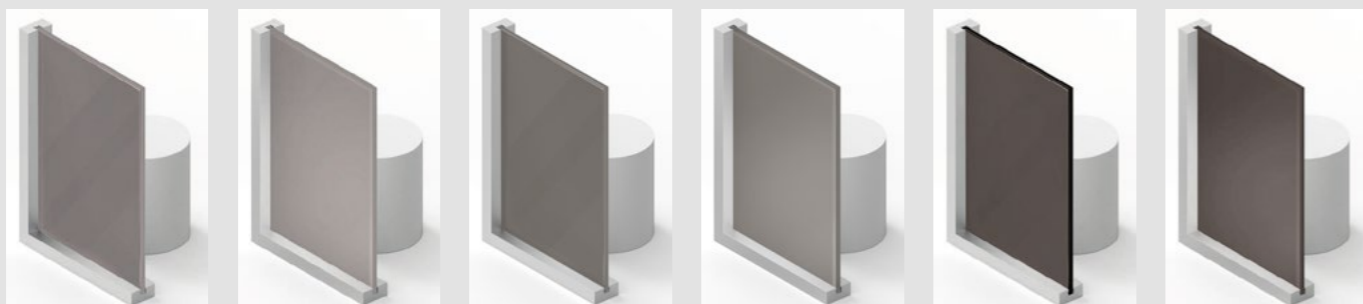

**Categoria / Category:** C    **Categoria / Category:** D    **Categoria / Category:** C    **Categoria / Category:** D    **Categoria / Category:** C    **Categoria / Category:** D

**Spessore / Thickness:**  
 • **Temperato / Tempered** 4 mm\*  
 • **Stratificato / Laminated** 3+3 | 5+5 | 6+6 mm

Grigio Gotham 2B    Grigio Gotham Satinato 5B    Nero 48    Nero Satinato 69



**Categoria / Category:** C    **Categoria / Category:** D    **Categoria / Category:** C    **Categoria / Category:** D

**Spessore / Thickness:**  
 • **Temperato / Tempered** 4 mm\*  
 • **Stratificato / Laminated** 3+3 | 5+5 | 6+6 mm

### Specchio / Mirror

Specchio 40    Specchio Bronzo 37



**Categoria / Category:** B    **Categoria / Category:** C

**Spessore / Thickness:**  
 • **Temperato / Tempered** 4 | 6 | 8 mm  
 • **Stratificato / Laminated** 5+5 | 6+6 mm

### Digital / Digital

Digital Mirror 90    Digital Black 91    On/Off



Vetri disponibili su progetto. Per dettagli, prezzi e compatibilità contattare l'ufficio commerciale.  
 Glasses available on a project. For details, prices and compatibility contact the sales office.

### Compatibilità / Compatibilities

Tipologia Typology	Nome finitura Finishing name	Codice Code	Categoria Category	Prima	Quadra	Celine	Ri-trait	Ri-trait 8b	Integra	Next	Suit	Entre-deux	Dot	Sail	Quies	And	Morbida	Ring	Blow	Level	Boisé	All Ways	Boiserie	Solo/Ri-vista	Girevole	Nile
Laccati Laquered	Neve extrachiaro	53	D	●	●	●	●	●	●	●	●	●	●	●	●	●	●	●	●	●	●	●	●	●	●	
	Neve acidato extrachiaro	51	D	●	●	●	●	●	●	●	●	●	●	●	●	●	●	●	●	●	●	●	●	●	●	
	Polvere	72	D	●	●	●	●	●	●	●	●	●	●	●	●	●	●	●	●	●	●	●	●	●	●	
	Polvere Satinato	74	D	●	●	●	●	●	●	●	●	●	●	●	●	●	●	●	●	●	●	●	●	●	●	
	Sabbia	9A	C	●	●	●	●	●	●	●	●	●	●	●	●	●	●	●	●	●	●	●	●	●	●	
	Sabbia Satinato	3B	D	●	●	●	●	●	●	●	●	●	●	●	●	●	●	●	●	●	●	●	●	●	●	
	Tortora	38	C	●	●	●	●	●	●	●	●	●	●	●	●	●	●	●	●	●	●	●	●	●	●	
	Tortora Satinato	67	D	●	●	●	●	●	●	●	●	●	●	●	●	●	●	●	●	●	●	●	●	●	●	
	Cenere	4A	C	●	●	●	●	●	●	●	●	●	●	●	●	●	●	●	●	●	●	●	●	●	●	
	Cenere Satinato	5A	D	●	●	●	●	●	●	●	●	●	●	●	●	●	●	●	●	●	●	●	●	●	●	
	Grigio Londra	1B	C	●	●	●	●	●	●	●	●	●	●	●	●	●	●	●	●	●	●	●	●	●	●	
	Grigio Londra Satinato	4B	D	●	●	●	●	●	●	●	●	●	●	●	●	●	●	●	●	●	●	●	●	●	●	
Grigio Gotham	2B	C	●	●	●	●	●	●	●	●	●	●	●	●	●	●	●	●	●	●	●	●	●	●		
Grigio Gotham Satinato	5B	D	●	●	●	●	●	●	●	●	●	●	●	●	●	●	●	●	●	●	●	●	●	●		
Nero	48	C	●	●	●	●	●	●	●	●	●	●	●	●	●	●	●	●	●	●	●	●	●	●		
Nero Satinato	69	D	●	●	●	●	●	●	●	●	●	●	●	●	●	●	●	●	●	●	●	●	●	●		
Specchi Mirror	Specchio	40	B	●	●	●	●	●	●	●	●	●	●	●	●	●	●	●	●	●	●	●	●	●		
	Specchio Bronzo	37	C	●	●	●	●	●	●	●	●	●	●	●	●	●	●	●	●	●	●	●	●	●		

\*I vetri temperati monolitici vengono laccati solo sulla faccia interna del vetro.  
 \*Monolithic tempered glass is lacquered only on the internal face of the glass.

In alcuni casi particolari i vetri opachi possono essere realizzati a progetto in lastre monolitiche temperate con spessori diversi da quelli indicati (5mm, 6mm).  
 Per dettagli, prezzi e compatibilità contattare l'ufficio commerciale.  
 In special be-spoke applications opaque glasses can be made in monolithic tempered plates with custom thicknesses other than those indicated (5mm or 6mm).  
 For details, prices and compatibility contact the sales office.

Informazioni generali / General informations  
 Porte battenti con cornice / Hinged door and frame  
 Porte effetto filomuro / Flush-effect door  
 Porte filomuro / Flush door  
 Porte senza falso telaio / Door w/o basic door frame  
 Porte a scomparsa / Pocket door  
 Pan. scorrevoli o girevoli / Sliding or pivoting panels  
 Paredi divisorie / Partition wall  
 Boiserie / Boiserie  
 Cabine armadio / Walk-in closet  
 Librerie / Bookcase  
 Tavoli / Table

Informazioni generali / General informations  
 Porte battenti con cornice / Hinged door and frame  
 Porte effetto filomuro / Flush-effect door  
 Porte filomuro / Flush door  
 Porte senza falso telaio / Door w/o basic door frame  
 Porte a scomparsa / Pocket door  
 Pan. scorrevoli o girevoli / Sliding or pivoting panels  
 Paredi divisorie / Partition wall  
 Boiserie / Boiserie  
 Cabine armadio / Walk-in closet  
 Librerie / Bookcase  
 Tavoli / Table

# Vetri con reti e tessuti

## Glass with fabric and mesh

### Fabric

Texture

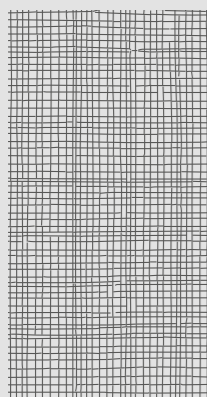

Fabric White

80

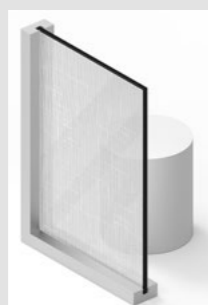

Categoria / Category: E

Spessore / Thickness:  
• Stratificato / Laminated  
3+3 | 4+4 | 5+4 | 6+6 mm

Fabric Black

81



Categoria / Category: E

Spessore / Thickness:  
• Stratificato / Laminated  
3+3 | 4+4 | 5+4 | 6+6 mm

### Mesh

Texture

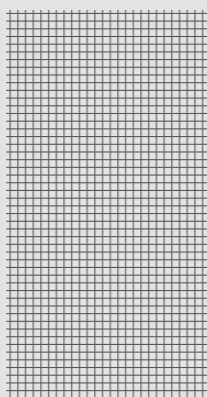

Alu Natural Mesh

82

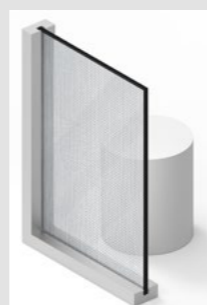

Categoria / Category: E

Spessore / Thickness:  
• Stratificato / Laminated  
3+3 | 4+4 | 5+4 | 6+6 mm

Gold Mesh

83



Categoria / Category: E

Spessore / Thickness:  
• Stratificato / Laminated  
3+3 | 4+4 | 5+4 | 6+6 mm

### Matisse

Texture

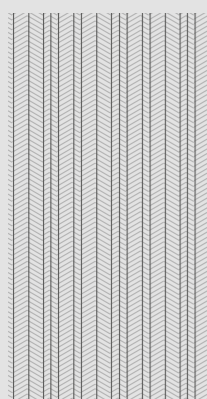

Matisse Aluminium

1A



Categoria / Category: E

Spessore / Thickness:  
• Stratificato / Laminated  
3+3 | 4+4 | 5+4 | 6+6 mm

Matisse Gris

3A



Categoria / Category: E

Spessore / Thickness:  
• Stratificato / Laminated  
3+3 | 4+4 | 5+4 | 6+6 mm

Matisse Doré

2A



Categoria / Category: E

Spessore / Thickness:  
• Stratificato / Laminated  
3+3 | 4+4 | 5+4 | 6+6 mm

Matisse Bronze

2C



Categoria / Category: E

Spessore / Thickness:  
• Stratificato / Laminated  
3+3 | 4+4 | 5+4 | 6+6 mm

### Monet

Texture

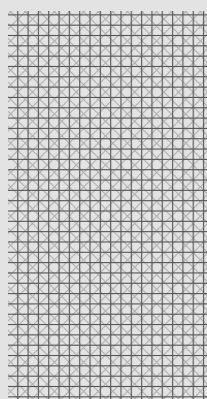

Monet Aluminium

3C

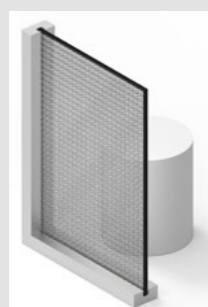

Categoria / Category: E

Spessore / Thickness:  
• Stratificato / Laminated  
4+4 | 5+4 | 6+6 mm +  
1 mm texture

Monet Gris

5C

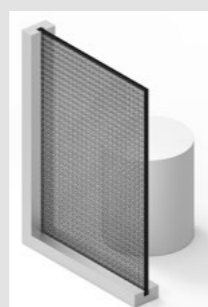

Categoria / Category: E

Spessore / Thickness:  
• Stratificato / Laminated  
4+4 | 5+4 | 6+6 mm +  
1 mm texture

Monet Doré

4C

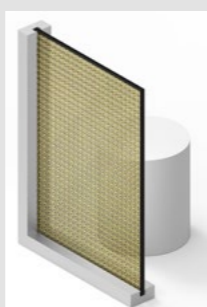

Categoria / Category: E

Spessore / Thickness:  
• Stratificato / Laminated  
4+4 | 5+4 | 6+6 mm +  
1 mm texture

Monet Bronze

6C

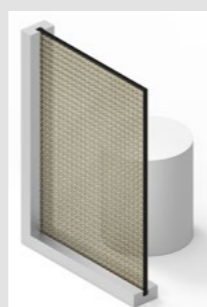

Categoria / Category: E

Spessore / Thickness:  
• Stratificato / Laminated  
4+4 | 5+4 | 6+6 mm +  
1 mm texture

### Deluxe

Texture

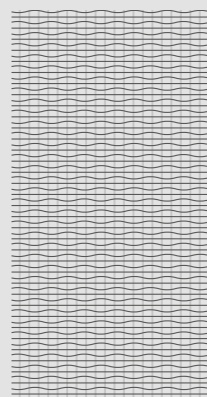

Deluxe Silver

86

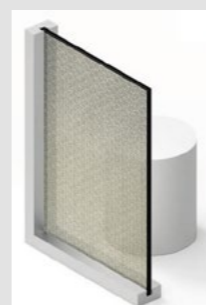

Categoria / Category: E

Spessore / Thickness:  
• Stratificato / Laminated  
3+3 | 4+4 | 5+4 | 6+6 mm

Deluxe Gold

85

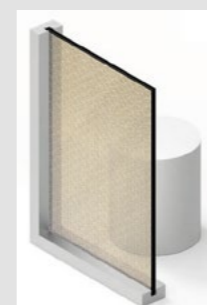

Categoria / Category: E

Spessore / Thickness:  
• Stratificato / Laminated  
3+3 | 4+4 | 5+4 | 6+6 mm

### Compatibilità / Compatibilities

Tipologia Typology	Nome finitura Finishing name	Codice Code	Categoria Category	Compatibilità / Compatibilities																					
				Prima	Quadra	Celine	Ri-trait	Ri-trait 8b	Integra	Next	Suit	Entre-deux	Dot	Sail	Oules	And	Morbida	Ring	Blow	Level	Boisé	All Ways	Boiserie	Solo/RI-vista	Girevole
	Fabric White	80	E	●	●	●	●	●	●	●	●	●	●	●	●	●	●	●	●	●	●	●	●	●	●
	Fabric Black	81	E	●	●	●	●	●	●	●	●	●	●	●	●	●	●	●	●	●	●	●	●	●	●
	Alu Natural Mesh	82	E	●	●	●	●	●	●	●	●	●	●	●	●	●	●	●	●	●	●	●	●	●	●
	Gold mesh	83	E	●	●	●	●	●	●	●	●	●	●	●	●	●	●	●	●	●	●	●	●	●	●
	Deluxe Silver	86	E	●	●	●	●	●	●	●	●	●	●	●	●	●	●	●	●	●	●	●	●	●	●
	Deluxe Gold	85	E	●	●	●	●	●	●	●	●	●	●	●	●	●	●	●	●	●	●	●	●	●	●
Vetri con reti e tessuti Glass with fabric and mesh	Matisse Aluminium	1A	E	●	●	●	●	●	●	●	●	●	●	●	●	●	●	●	●	●	●	●	●	●	●
	Matisse Gris	3A	E	●	●	●	●	●	●	●	●	●	●	●	●	●	●	●	●	●	●	●	●	●	●
	Matisse Doré	2A	E	●	●	●	●	●	●	●	●	●	●	●	●	●	●	●	●	●	●	●	●	●	●
	Matisse Bronze	2C	E	●	●	●	●	●	●	●	●	●	●	●	●	●	●	●	●	●	●	●	●	●	●
	Monet Aluminium	3C	E	●	●	●	●	●	●	●	●	●	●	●	●	●	●	●	●	●	●	●	●	●	●
	Monet Gris	5C	E	●	●	●	●	●	●	●	●	●	●	●	●	●	●	●	●	●	●	●	●	●	●
	Monet Doré	4C	E	●	●	●	●	●	●	●	●	●	●	●	●	●	●	●	●	●	●	●	●	●	●
	Monet Bronze	6C	E	●	●	●	●	●	●	●	●	●	●	●	●	●	●	●	●	●	●	●	●	●	●

\*non disponibile per Quadra doppio vetro e Quadra soffiato vetro singolo

\*not available for Quadra double glass and Folding Quadra single glass

Le reti e i tessuti possono presentare delle leggere ondulazioni, a seguito della stratifica a caldo dei doppi vetri, che attribuiscono al materiale il suo caratteristico aspetto naturale.  
The fabric and the mesh can have slight undulations due to the stratification process of double glasses that attributes to the material its characteristic natural appearance.

I vetri con reti e tessuti possono essere realizzati a progetto in versione opaca per applicazioni su Boiserie o pannelli porta. Per dettagli, prezzi e compatibilità contattare l'ufficio commerciale.  
Laminated glasses with nets and fabrics can be applied on boiserie or door panels for be-spoke applications. For details, prices and compatibility contact the sales office.

# Caratteristiche tecniche dei vetri

## Technical characteristics of the glass

### Temperati Tempered

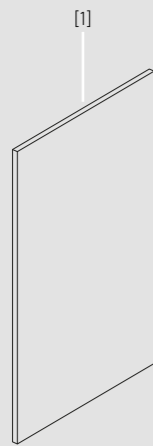

Vetri che sono sottoposti al trattamento della tempra, ossia ad una cottura del vetro alla temperatura di 650°/700° C, seguita rapidamente dal raffreddamento forzato. Questa procedura porta la resistenza meccanica del vetro ad essere superiore di 5 volte rispetto ad un vetro normale.

Nel caso di rottura, i vetri temperati si sbriciolano in piccoli frammenti inoffensivi.

I vetri proposti da Albed rispettano tutte le normative vigenti in materia di sicurezza per i vetri d'arredamento.

I vetri temperati sono disponibili negli spessori di: 4, 6 e 8 mm

The treatment to which tempered glasses are subjected consists in the firing of the glass up to 650° / 700° C, rapidly followed by a forced cooling. Through this process the glass reaches a mechanical resistance that is 5 times higher than a normal glass.

If broken, tempered glasses crumble into small harmless fragments.

The glasses used by Albed comply with all the current regulations in the field of safety furnishing glasses safety.

Tempered glasses are available in thicknesses of: 4, 6 and 8 mm.

### Stratificati Laminated

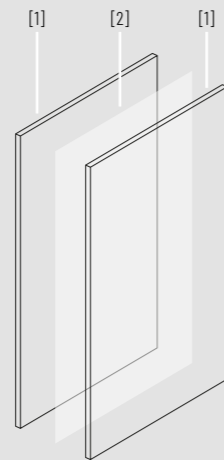

Vetri composti da due lastre [1] fra cui è inserita una sottile pellicola di materiale plastico [2], trasparente ed invisibile, che aderisce completamente alle due superfici.

A richiesta, è possibile avere un materiale plastico specifico che aumenti le capacità di isolamento acustico.

Nel caso di rottura dei vetri stratificati, il materiale plastico al suo interno trattiene i frammenti.

I vetri proposti da Albed rispettano tutte le normative vigenti in materia di sicurezza per i vetri d'arredamento. I vetri stratificati sono disponibili negli spessori di: 3+3, 4+4, 4+6, 5+5 e 6+6 mm

Laminated glasses consist in two glass plates [1] between which a thin film of plastic material [2] is inserted. The plastic film is transparent and invisible, and fully adheres to the two surfaces.

On request, it is possible to have a specific plastic film that increases the sound-proof capacity.

The glasses used by Albed comply with all the current regulations in the field of safety furnishing glasses safety.

If broken, the fragments remain glued to the plastic film inside the laminated glass. Laminated glasses are available in thicknesses of: 3+3, 4+4, 5+5 and 6+6mm

### Temperati riflettenti Reflex tempered



I vetri riflettenti sono dei vetri temperati [1] a cui viene applicato uno strato di ossidi metallici [2] a caldo su un lato della lastra.

Nel caso di rottura, i vetri temperati, si sbriciolano in piccoli frammenti inoffensivi.

I vetri proposti da Albed rispettano tutte le normative vigenti in materia di sicurezza per i vetri d'arredamento.

I vetri temperati sono disponibili negli spessori di: 4, 6 e 8 mm

Reflex glasses are tempered glasses (1) on which a layer of metal oxides (2) is applied hot on one side of the glass.

If broken, tempered glasses crumble into small harmless fragments.

The glasses used by Albed comply with all the current regulations in the field of furnishing glasses safety.

Tempered glasses are available in thicknesses of: 4, 6 and 8 mm.

### Laccati temperati Laquered tempered

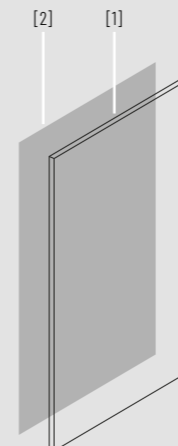

I vetri laccati sono prodotti tramite laccatura [2] di un lato del vetro temperato [1]. Il lato "bello" della lastra sarà sempre quello non verniciato. In modo da mantenere colori inalterabili nel tempo e al sicuro da macchie, polvere e umidità.

Nel caso di rottura, i vetri temperati, si sbriciolano in piccoli frammenti inoffensivi.

I vetri proposti da Albed rispettano tutte le normative vigenti in materia di sicurezza per i vetri d'arredamento.

I vetri temperati sono disponibili negli spessori di: 4mm

Lacquered glasses are obtained by the lacquering process (2) of one side of the tempered glass.

If broken, tempered glasses crumble into small harmless fragments.

The glasses used by Albed comply with all the current regulations in the field of furnishing glasses safety.

Tempered glasses are available in thicknesses of: 4 and 6 mm.

### Laccati stratificati Laquered laminated

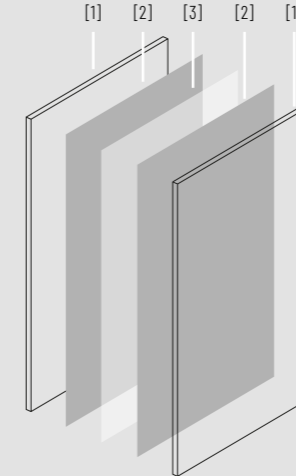

I vetri laccati stratificati sono prodotti tramite laccatura [2] di un lato di due vetri [1] accoppiati con una sottile pellicola di materiale plastico [3], trasparente ed invisibile, che aderisce completamente alle due superfici.

A richiesta, è possibile avere un materiale plastico specifico che aumenti le capacità di isolamento acustico.

Nel caso di rottura dei vetri stratificati, il materiale plastico al suo interno trattiene i frammenti.

I vetri stratificati sono disponibili negli spessori di: 3+3, 5+5 e 6+6 mm

Laquered laminated glasses are obtained by the lacquering process (2) of one side of the two glasses (1) combined with a thin transparent and invisible plastic film (3) that completely sticks to the two surfaces.

On request, it is possible to have a specific plastic film that increases the sound-proof capacity.

If broken, the fragments remain glued to the plastic film inside the laminated glass.

Laminated glasses are available in thicknesses of: 3+3, 4+4, 5+5 and 6+6mm

### Stratificati con reti e tessuti / Laminated with mesh and fabric

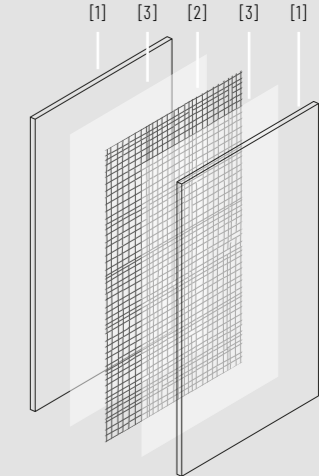

Vetri composti da due lastre [1], due sottili pellicole in materiale plastico [2], tra cui è inserito un tessuto o una rete metallica [3].

A richiesta, è possibile avere un materiale plastico specifico che aumenti le capacità di isolamento acustico.

Nel caso di rottura dei vetri stratificati, il materiale plastico al suo interno trattiene i frammenti.

I vetri stratificati sono disponibili negli spessori di: 3+3, 5+5 e 6+6 mm

Glasses composed of two plates (1) two thin plastic films (2) between which a fabric or a mesh is inserted (3).

On request, it is possible to have a specific plastic film that increases the sound-proof capacity.

If broken, the fragments remain glued to the plastic film inside the laminated glass.

Laminated glasses are available in thicknesses of: 3+3, 4+4, 5+5 and 6+6mm



# Legno Wood

## Essenze legno / Wood essences



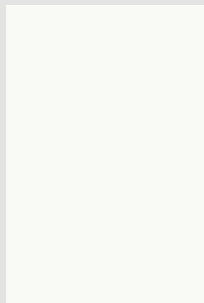
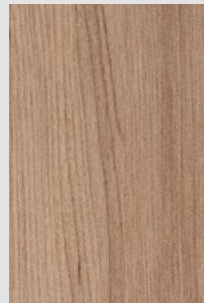
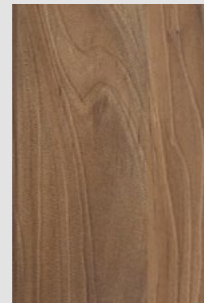
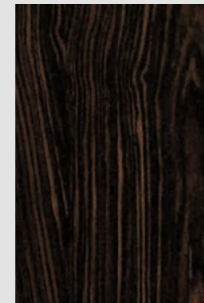

<b>Frassino Neve</b> <b>FN</b>	<b>Rovere Chiaro</b> <b>RC</b>	<b>Rovere Decapè</b> <b>RD</b>	<b>Rovere Miele</b> <b>RM</b>	<b>Noce Canaletto</b> <b>NC</b>
				
<b>Categoria / Category: 4</b>	<b>Categoria / Category: 4</b>	<b>Categoria / Category: 4</b>	<b>Categoria / Category: 4</b>	<b>Categoria / Category: 4</b>
<b>Fiammato, venatura verticale</b> Flamed, vertical grain	<b>Rigato, venatura verticale</b> Lined, vertical grain	<b>Fiammato, venatura verticale</b> Flamed, vertical grain	<b>Fiammato, venatura verticale</b> Flamed, vertical grain	<b>Rigato, venatura orizzontale</b> Lined, horizontal grain

<b>Noce Tabacco</b> <b>NT</b>	<b>Noce Moka</b> <b>NM</b>	<b>Rovere Notte</b> <b>RN</b>	<b>Rovere Termotrattato</b> <b>RT</b>	<b>Frassino Carbone</b> <b>FC</b>
				
<b>Categoria / Category: 4</b>	<b>Categoria / Category: 4</b>	<b>Categoria / Category: 4</b>	<b>Categoria / Category: 4</b>	<b>Categoria / Category: 4</b>
<b>Fiammato, venatura verticale</b> Flamed, vertical grain	<b>Fiammato, venatura verticale</b> Flamed, vertical grain	<b>Fiammato, venatura verticale</b> Flamed, vertical grain	<b>Fiammato, venatura verticale</b> Flamed, vertical grain	<b>Fiammato, venatura verticale</b> Flamed, vertical grain

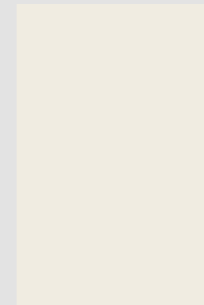

## Nobilitati / Nobilitati

<b>Nobilitato Talco</b> <b>WT</b>	<b>Nobilitato Louvre</b> <b>LV</b>	<b>Nobilitato Walnut</b> <b>WL</b>	<b>Nobilitato Ebony</b> <b>EB</b>	<b>Nobilitato Carbone</b> <b>CB</b>
				
<b>Categoria / Category: 1</b>	<b>Categoria / Category: 1</b>	<b>Categoria / Category: 2</b>	<b>Categoria / Category: 2</b>	<b>Categoria / Category: 1</b>
<b>Superficie tinta unita</b> Solid color surface	<b>Superficie fiammata</b> Flamed surface	<b>Superficie fiammata</b> Flamed surface	<b>Superficie fiammata</b> Flamed surface	<b>Superficie fiammata</b> Flamed surface

## Laccato / Lacquered

<b>Laccato standard RAL 9003</b> <b>LA</b>	<b>Laccato standard RAL 9010</b> <b>LB</b>	<b>Laccato standard RAL 7044</b> <b>LC</b>	<b>Laccato standard RAL 1019</b> <b>LD</b>	<b>Laccato custom RAL</b> <b>LR</b>
				
<b>Categoria / Category: -</b>	<b>Categoria / Category: -</b>	<b>Categoria / Category: -</b>	<b>Categoria / Category: -</b>	<b>Categoria / Category: 3</b>
<b>Verniciatura all'acqua opaca</b> Matt water-based paint	<b>Verniciatura all'acqua opaca</b> Matt water-based paint	<b>Verniciatura all'acqua opaca</b> Matt water-based paint	<b>Verniciatura all'acqua opaca</b> Matt water-based paint	<b>Verniciatura all'acqua opaca</b> Matt water-based paint

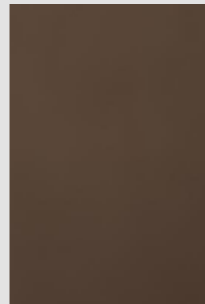
## Cuoio e cuoio rigenerato / Leather and regenerated leather

<b>Fango</b> <b>FG</b>	<b>Testa di Moro</b> <b>TM</b>
	
<b>Categoria / Category: 5</b>	<b>Categoria / Category: 5</b>

## Compatibilità / Compatibilities

Tipologia Typology	Prima	Quadra	Celme	Ri-trait	Ri-trait 8b	Integra	Next	Suit	Entre-deux	Dot	Sail	Quies	And	Morbida	Ring	Blow	Level	Boisé	All Ways	Boiserie	Solo/Ri-vista	Girevole	Nile
<b>Essenze legno / Wood essences</b>	●	●	●	●	●	●	●	●	●	●	●	●	●	●	●	●	●	●	●	●	●	●	●
<b>Nobilitati / Nobilitati</b>																					●	●	
<b>Laccato / Lacquered</b>	●	●	●	●	●	●	●	●	●	●	●	●	●	●	●	●	●	●	●	●	●	●	●
<b>Cuoio e cuoio rigenerato / Leather and regenerated leather</b>	●					●	●	●						●							●		

Informazioni generali / General informations  
 Porte battenti con cornice / Hinged door and frame  
 Porte effetto filomuro / Flush-effect door  
 Porte filomuro / Flush door  
 Porte senza falso telaio / Door w/o basic door frame  
 Porte a scomparsa / Pocket door  
 Pan. scorrevoli o girevoli / Sliding or pivoting panels  
 Pareti divisorie / Partition wall  
 Boiserie / Boiserie  
 Cabine armadio / Walk-in closet  
 Librerie / Bookcase  
 Tavoli / Table

Informazioni generali / General informations  
 Porte battenti con cornice / Hinged door and frame  
 Porte effetto filomuro / Flush-effect door  
 Porte filomuro / Flush door  
 Porte senza falso telaio / Door w/o basic door frame  
 Porte a scomparsa / Pocket door  
 Pan. scorrevoli o girevoli / Sliding or pivoting panels  
 Pareti divisorie / Partition wall  
 Boiserie / Boiserie  
 Cabine armadio / Walk-in closet  
 Librerie / Bookcase  
 Tavoli / Table

PORTE DOORS  
E AND  
PARETI DIVID-  
DIVISO- ING  
RIE WALLS

Informazioni generali / General informations  
 Porte battenti con cornice / Hinged door and frame  
 Porte effetto filomuro / Flush-effect door  
 Porte filomuro / Flush door  
 Porte senza falso telaio / Door w/o basic door frame  
 Porte a scomparsa / Pocket door  
 Pan. scorrevoli o girevoli / Sliding or pivoting panels  
 Pareti divisorie / Partition wall  
 Boiserie / Boiserie  
 Cabine armadio / Walk-in closet  
 Librerie / Bookcase  
 Tavoli / Table



# BATTENTI CON CORNICE

## HINGED DOOR AND FRAME

La porta "battente con cornice" è la porta tradizionale per eccellenza, può essere singola o doppia e con apertura a spingere o a tirare. Gli stipiti e i coprifili possono essere anche personalizzati a seconda delle esigenze progettuali.

The "hinged door and frame" is the traditional door par excellence. It can be single or double, with push or pull opening. The jambs and finishing lists can also be personalised to suit design needs.

### Sistema prodotto / Product system

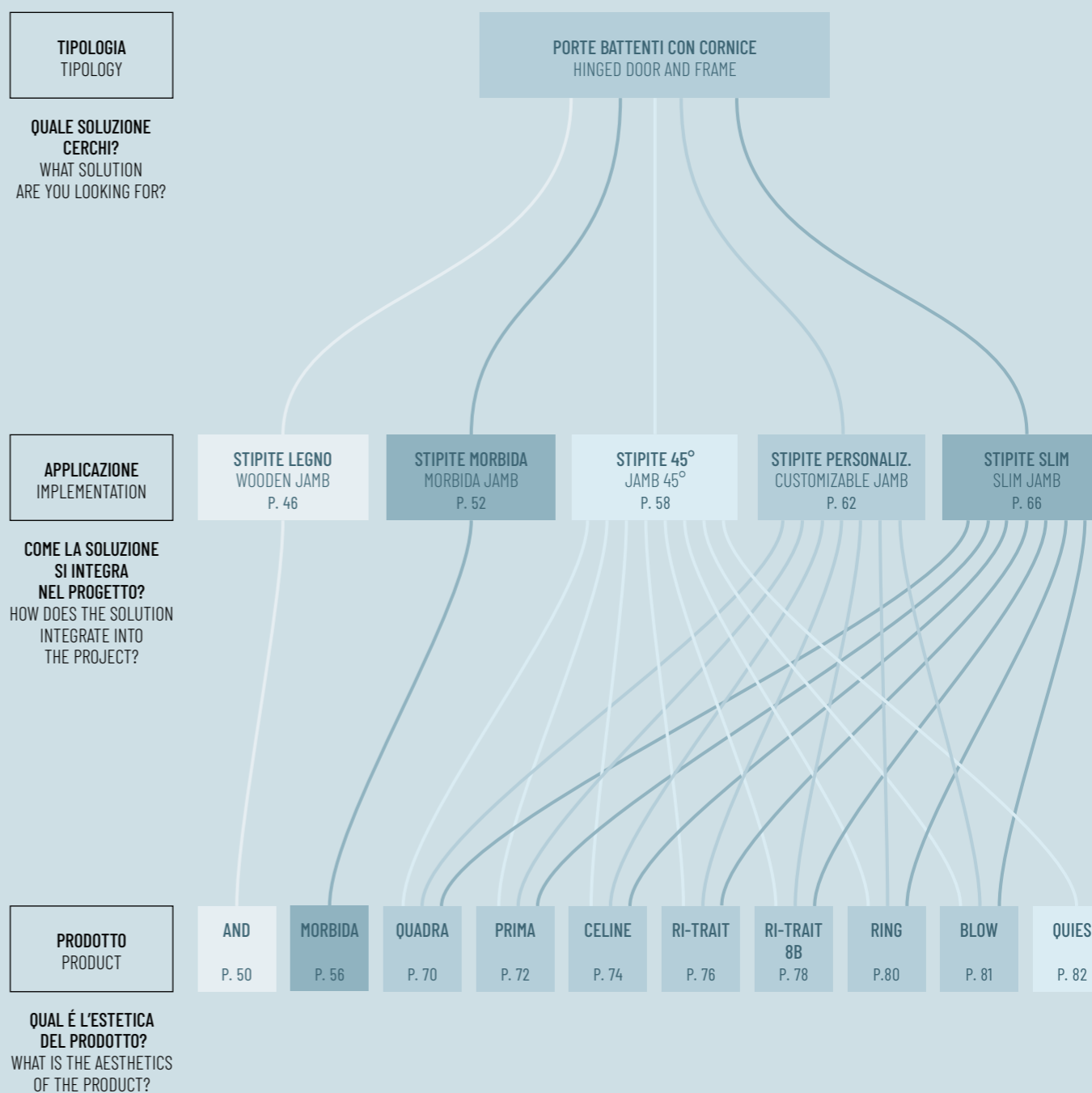

Informazioni generali / General informations  
 Porte battenti con cornice / Hinged door and frame  
 Porte effetto filomuro / Flush-effect door  
 Porte filomuro / Flush door  
 Porte senza falso telaio / Door w/o basic door frame  
 Porte a scomparsa / Pocket door  
 Pan. scorrevoli o girevoli / Sliding or pivoting panels  
 Pareti divisorie / Partition wall  
 Boiserie / Boiserie  
 Cabine armadio / Walk-in closet  
 Librerie / Bookcase  
 Tavoli / Table

# Stipite legno per porte battenti

## Wooden jamb for hinged door

Lo stipite in legno è la soluzione tradizionale per eccellenza del sistema porta. Si monta su un falso telaio in legno ed è adattabile a tutti gli spessori parete da 60mm a 300mm grazie al sistema telescopico integrato e agli aggiustaggi. Ospita delle cerniere a scomparsa, con un'apertura a 180° dell'anta (a tirare) o a 90° (a spingere). Albed utilizza cerniere certificate, regolabili sui 3 assi.

A wooden jamb is the best traditional solution for the door system. It is fitted into a wooden door frame and can be adapted to suit all wall thicknesses from 60 mm to 300 mm, thanks to the built-in telescopic system and the adjustments. It houses rebated hinges, allowing the door to open 180° (pull opening) or 90° (push opening). Albed uses certified hinges that can be adjusted on 3 axes.

### Porta singola / Single door



Porta singola a tirare  
Single pull door

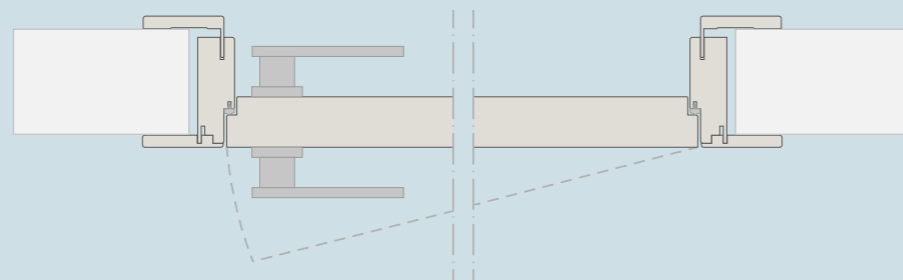

Porta singola a spingere  
Single push door

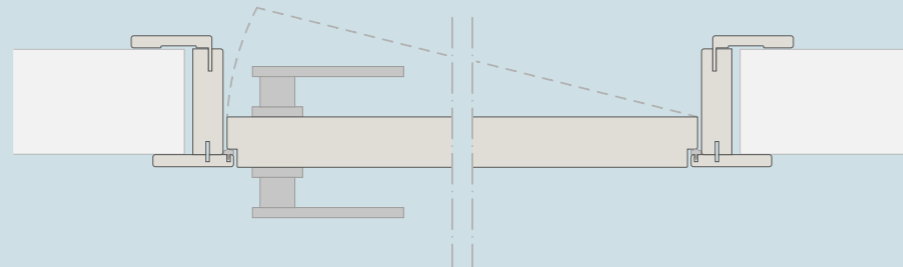

### Porta a due ante / Double door



Porta a due ante asimmetriche a tirare  
Asymmetrical double pull door

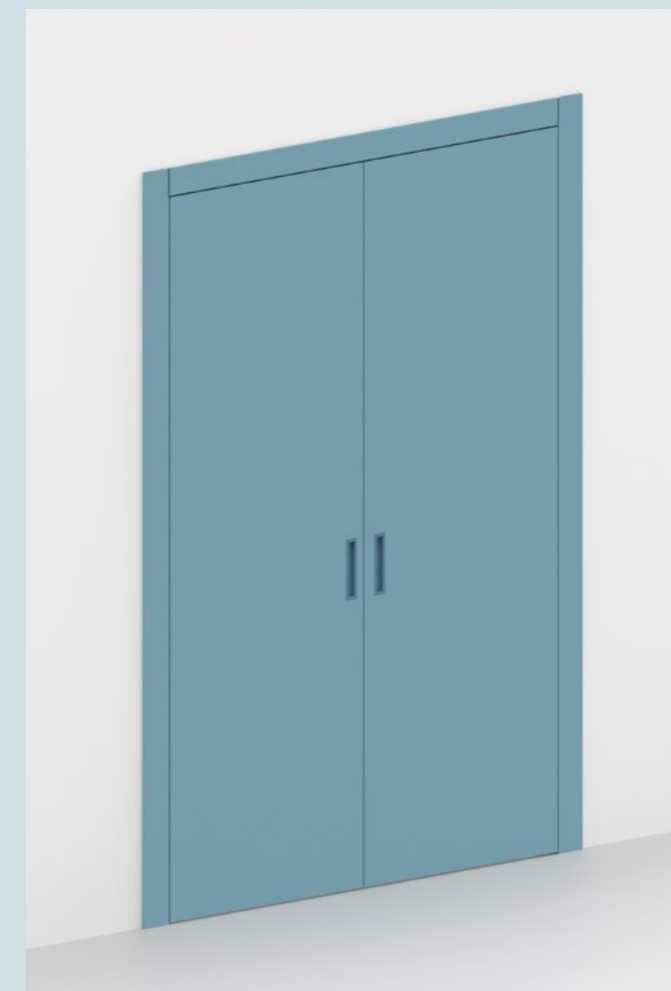
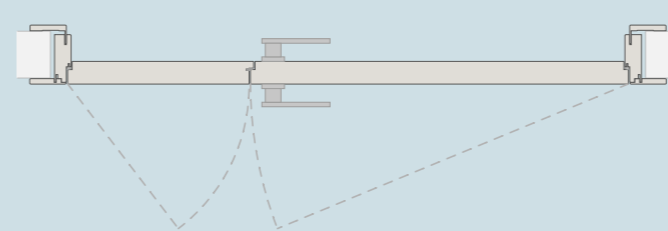

Porta a due ante simmetriche a tirare  
Symmetrical double pull door

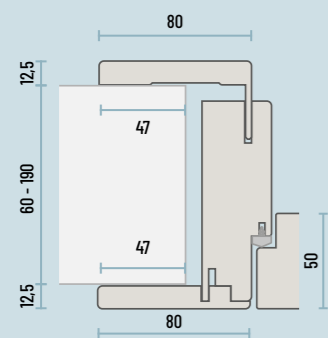
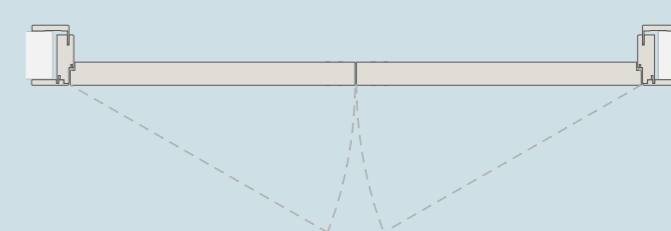

Dimensioni (mm) stipite legno per porte battenti a tirare  
Dimensions (mm) wooden jamb for pull hinged doors

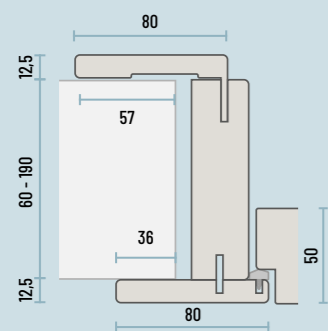

Dimensioni (mm) stipite legno per porte battenti a spingere  
Dimensions (mm) wooden jamb for push hinged doors



# Stipite legno per porte battenti

## Wooden jamb for hinged door

Compatibilità / Compatibilities

Dettagli / Details

And P. 50

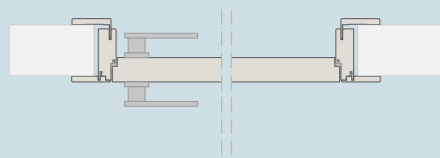

And a tirare  
And to pull

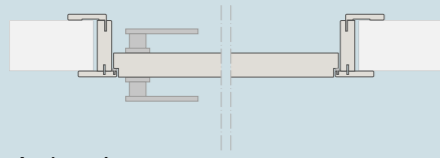

And a spingere  
And to push



**1. Sezione verticale Stipite legno con And a tirare**  
1. Vertical section Wooden jamb with And to pull

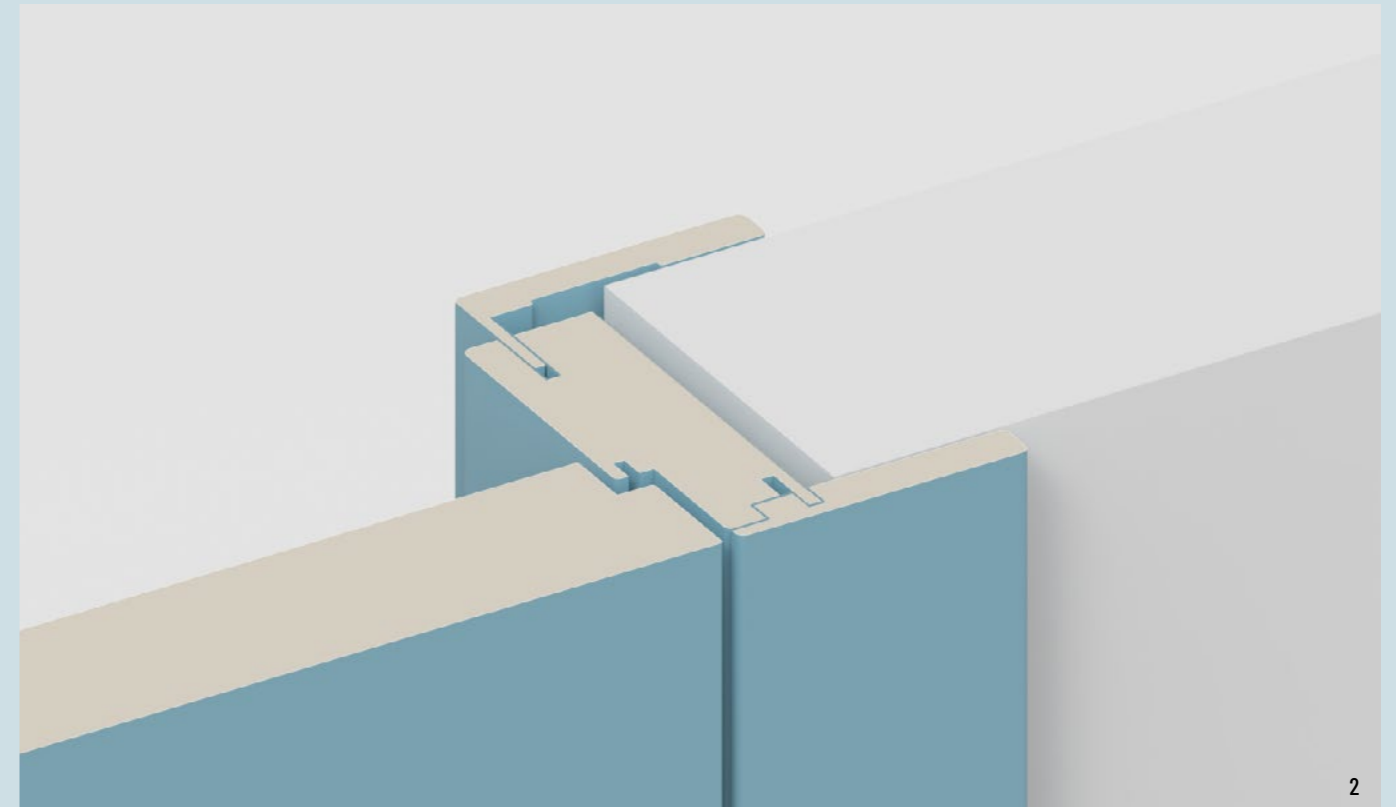

**2. Sezione orizzontale Stipite legno con And a tirare**  
2. Horizontal section Wooden jamb with And to pull

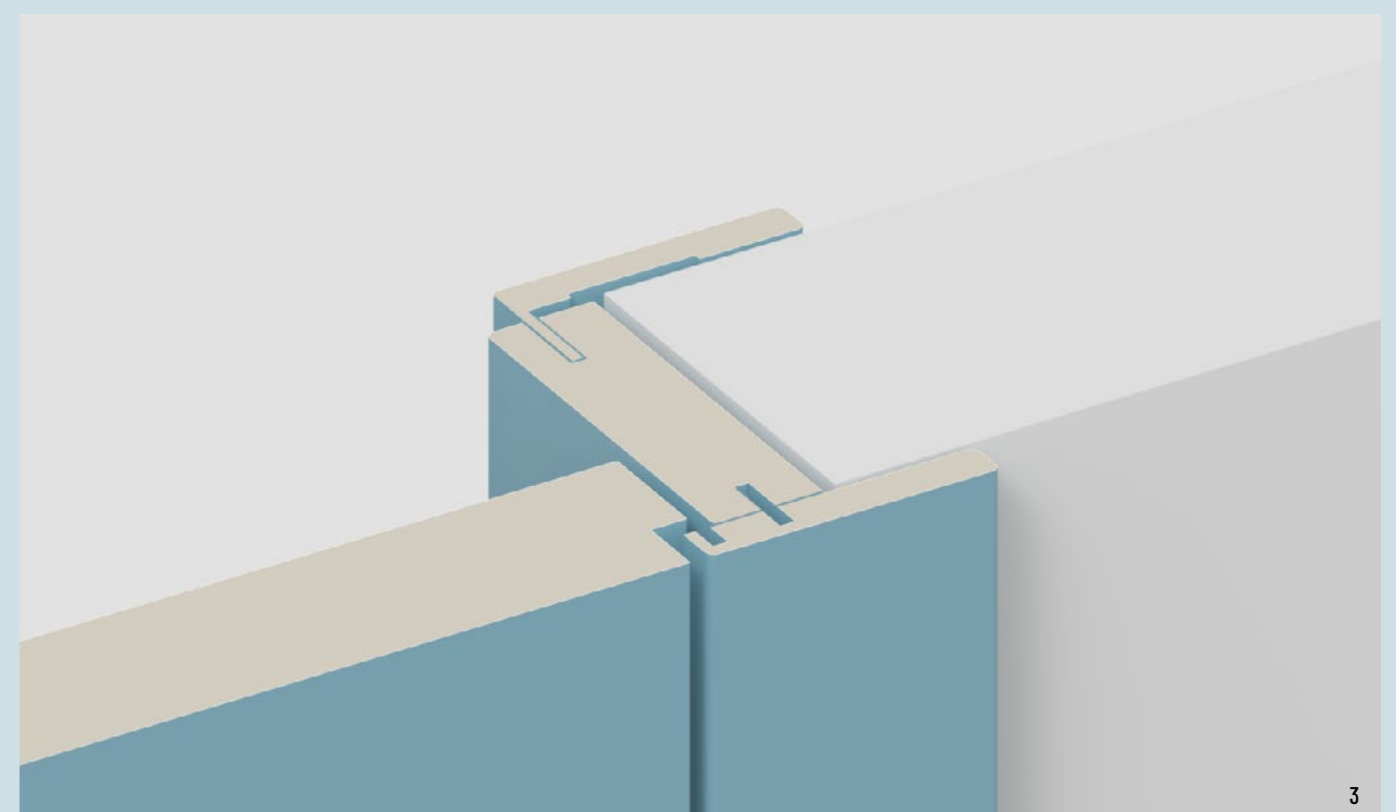

**3. Sezione orizzontale Stipite legno con And a spingere**  
3. Horizontal section Wooden jamb with And to push

# And battente con cornice

## And hinged door and frame

### 1 PORTE SINGOLE STANDARD / STANDARD SINGLE DOORS

Tipo pannello Panel type	Finitura pannello e stipite Panel and jamb finishing	Stipite legno Wooden jamb
Pannello legno Wooden panel	[1] Laccato standard / Standard lacquered	€ 950

### DIMENSIONI STANDARD / STANDARD SIZES

Porta singola Single door	Pannelli standard Standard panels	Controtelaio Counterframe
<b>A tirare o a spingere</b> To pull or to push	L 714/814 x H 2100	L 790/890 ±10 x H 2150 ±10

Al momento dell'ordine specificare il senso di apertura:  
tirare o spingere e sinistra o destra  
When ordering, specify the opening side of the door:  
pull or push and left or right.

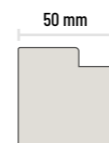

Pannello And  
And panel

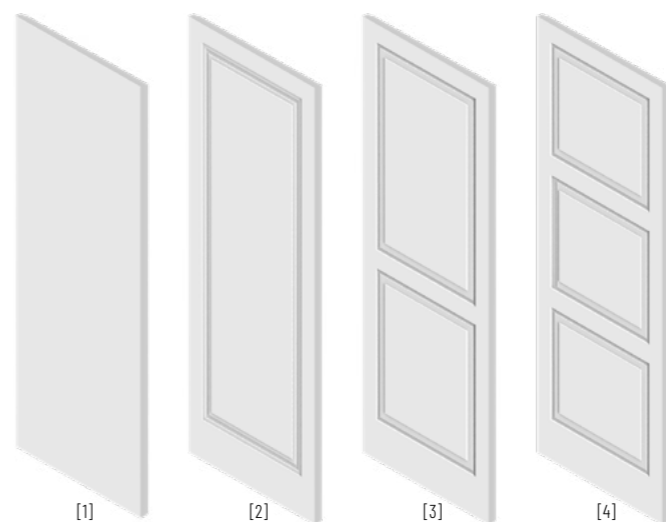

[1] Pannello legno  
Wooden panel

[2] Pannello legno pantografato 1 riquadro  
Grooving wooden panel 1 square

[3] Pannello legno pantografato 2 riquadri  
Grooving wooden panel 2 squares

[4] Pannello legno pantografato 3 riquadri  
Grooving wooden panel 3 squares

### 2 DIMENSIONI CUSTOM / CUSTOM SIZES

Tipo pannello Panel type	Per controtelaio: For counterframes:	L < 1090 ±10
Pannello legno Wooden panel	H < 2200 ±10	+ € 140
	H < 2700 ±10	+ € 350

Per qualsiasi larghezza custom per controtelaio fino a L 1090 ±10 (per porta singola) o fino a L 2090 ±10 (per porta a due ante)  
For any custom width for counterframe up to L 1090 ±10 (for single door) or up to L 2090 ±10 (for double door)

### 3 FINITURE / FINISHINGS

Tipo pannello Panel type	Finitura Finishing	P. 30
Pannello legno Wooden panel	Laccato custom RAL Custom RAL lacquered	+ € 190

### 4 PERSONALIZZAZIONI / PERSONALIZATIONS

Tipo pannello Panel type	Pantografatura Grooving	
Pannello legno Wooden panel	1 riquadro / 1 square [2]	+ € 250
	2 riquadri / 2 squares [3]	
	3 riquadri / 3 squares [4]	

### 5 PORTE A DUE ANTE / DOUBLE DOORS

Tipo pannello Panel type	Porta a due ante Double door	
Pannello legno Wooden panel	Due ante asimmetriche Asymmetrical double door	+ 80%
	Due ante simmetriche Symmetrical double door	+ 90%

Porta a due ante disponibili per controtelai da L 1190 ±10 a L 2090 ±10  
Double doors available for counterframes from L 1190 ±10 to L 2090 ±10

Porta a due ante asimmetriche è formata da un pannello porta L814 + un pannello semifisso di L tale da riempire il controtelaio  
Symmetrical double door is made up from a door panel L814 + a semi-fixed panel of Width such as to fill the counter frame

Porta a due ante simmetriche è formata da due pannelli di Larghezza uguale  
Symmetrical double door is made up of two panels of equal Width

### 6 SISTEMI DI CHIUSURA / CLOSING SYSTEMS

Tipo pannello Panel type	Sistema di chiusura Closing system	Senza blocco Whitout block	Chiave Patent Patent key	Nottolino Latch free/busy	Chiave Yale Yale key
Pannello legno Wooden panel	Serr. scrocco magn. per maniglia standard Lock with magnetic latch for standard handles	+ € 90 *	+ € 45	+ € 45	+ € 50 **
	Chiusura magnetica senza scrocco <sup>1</sup> Magnetic closing without latch <sup>1</sup>	+ € 50	-	-	-

<sup>1</sup> disponibile solo per Porta a due ante simmetriche.  
Per questa opzione è necessario ordinare due elementi  
<sup>1</sup> available only for Symmetrical double door.  
For this option order two elements.

\* il prezzo comprende serratura e opzione "solo foro maniglia"  
\* price includes lock and "handle hole only" option

\*\* il prezzo non comprende il cilindro Yale  
\*\* price does not include Yale cylinder

### 7 MANIGLIE / HANDLES

Tipo pannello Panel type	Sistema di chiusura Closing system	Maniglia Handle	Solo maniglia Only handle	Chiave Patent Patent key	Nottolino Latch free/busy	Chiave Yale Yale key
Pannello legno Wooden panel	Serr. scrocco magnetico per maniglia standard Lock with magnetic latch for standard handles	Etna	+ € 190	+ € 190	+ € 210	+ € 190
		Vesuvio**	+ € 230	+ € 230	+ € 250	+ € 230
		Vulcano	+ € 190	+ € 190	+ € 210	+ € 190
		Fuji	+ € 80	+ € 80	+ € 110	+ € 80
	Teide	+ € 80	+ € 80	+ € 110	+ € 80	
	Chiusura magn. snz scrocco Magnetic closing without latch	Piave	+ € 80	-	-	-

\* Per Porta a due ante simmetriche ordinare due elementi / For Symmetrical double door order two elements

\*\* Al momento dell'ordine specificare la scelta tra rosetta e bocchetta quadrata o tonda / When ordering, specify the choice between square or round rosette and escutcheon

### 8 ACCESSORI STIPITE / JAMBS ACCESSORIES

Stipite Jamb	Accessorio stipite Accessorio stipite	Pagina listino Page price book
Stipite legno Wooden jamb	Aggiustaggi / Adjustments Rifili / Trims	P. 83

Aggiustaggi e rifili sono necessari quando i muri hanno un range di spessore diverso da 104mm-120mm  
Adjustments and trims are necessary when the walls have a thickness range different from 106mm-120mm

### CODICI PORTE / DOORS CODES

Tipo pannello Panel type	Stipite legno / Wooden jamb			
	Porta singola / Single door		Porta a due ante / Double door	
	Tirare Pull	Spingere Push	Asimmetriche Asymmetrical	Simmetriche Symmetrical
[1]	AN-BT10	AN-BT20	ANPA910	ANPA901
[2]	AN-BT12	AN-BT22	ANPA912	ANPA902
[3]	AN-BT14	AN-BT24	ANPA914	ANPA903
[4]	AN-BT16	AN-BT26	ANPA916	ANPA904

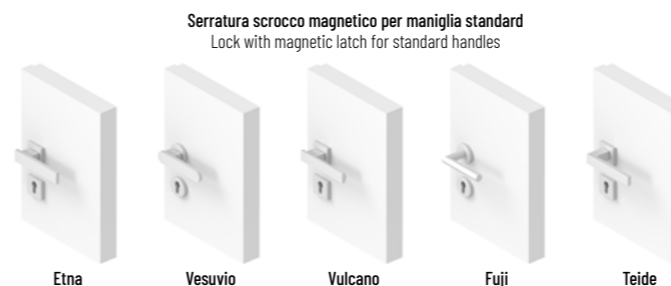

Etna

Vesuvio

Vulcano

Fuji

Teide

Chiusura magnetica senza scrocco  
Magnetic closing without latch



Piave

### CODICI SISTEMI DI CHIUSURA / CLOSING SYSTEMS CODES

Sistema di chiusura Closing system	Senza blocco Without block	Chiave Patent Patent key	Nottolino Latch free/busy	Chiave Yale Yale key
Serr. scrocco magnetico per maniglia standard Lock with magnetic latch for standard handles	LV-PS1	LV-PS1	LV-PS2	LV-PS3
Chiusura magnetica senza scrocco Magnetic closing without latch	MT-100	-	-	-

Configurazioni serratura scrocco magnetico per maniglia standard  
Lock with magnetic latch for standard handles configurations

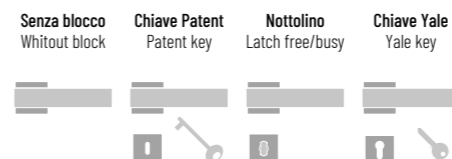

### CODICI MANIGLIE / HANDLES CODES

Maniglia Handle	Solo maniglia Only handle	Chiave Patent Patent key	Nottolino Latch free/busy	Chiave Yale Yale key
Etna	AC-350C	AC-350C	AC-350N	AC-350Y
Vesuvio*	AC-550C	AC-550C	AC-550N	AC-550Y
Vesuvio**	AC-555C	AC-555C	AC-555N	AC-555Y
Vulcano	AC-450C	AC-450C	AC-450N	AC-450Y
Fuji***	AC-120C	AC-120C	AC-120N	AC-120Y
Teide***	AC-220C	AC-220C	AC-220N	AC-120Y
Piave	QX	-	-	-

\* Versione con rosetta e bocchetta quadrata / Square rosette and escutcheon version

\*\* Versione con rosetta e bocchetta tonda / Circular rosette and escutcheon version

\*\*\* Disponibile solo in finitura acciaio / Available only in steel finish

# Stipite Morbida per porte battenti

## Morbida jamb for hinged door

Lo stipite Morbida reinterpreta i classici con cerniera a scomparsa. I suoi stipiti verticali in alluminio raccordano la superficie del pannello porta a quella della parete per un effetto unico. Il traverso orizzontale estende la superficie del pannello porta e può essere configurato in diverse altezze. La continuità tra le superfici è ancora maggiore con i sistemi boiserie Albed. Morbida si monta su un falso telaio in legno ed è adattabile a tutti gli spessori parete da 60mm a 300mm (con aggiustaggi). Ospita delle cerniere a scomparsa, con un'apertura a 180° dell'anta (a tirare) o a 90° (a spingere). Albed utilizza cerniere certificate, regolabili sui 3 assi.

The Morbida jamb reinvents concealed hinges classics. Its vertical aluminium jambs bridge the door panel surface with that of the wall creating a continuous surfaces unique effect. The horizontal jamb extends the door panel surface and can be configured to different heights. The continuity between surfaces is even greater with Albed boiserie systems. Morbida is mounted on a wooden subframe and is adaptable to all wall thicknesses from 60mm to 300mm (with adjustments). It accommodates concealed hinges, with 180° door opening (pull) or 90° opening (push). Albed uses certified hinges, adjustable on 3 axes.

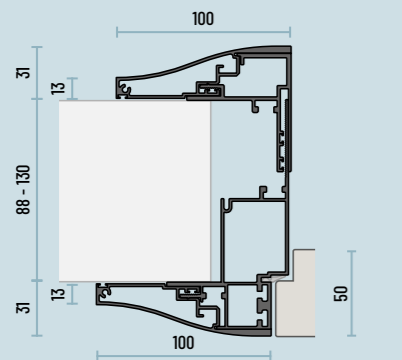

Dimensioni (mm) stipite Morbida per porte battenti a tirare  
Dimensions (mm) Morbida jamb for pull hinged doors

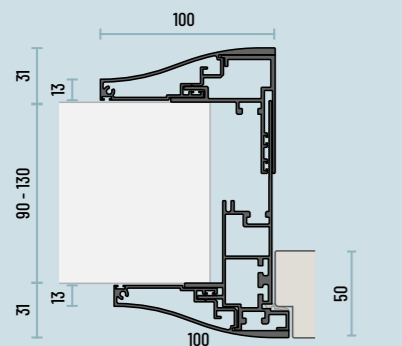

Dimensioni (mm) stipite Morbidat per porte battenti a spingere  
Dimensions (mm) Morbida jamb for push hinged doors

### Porta singola / Single door

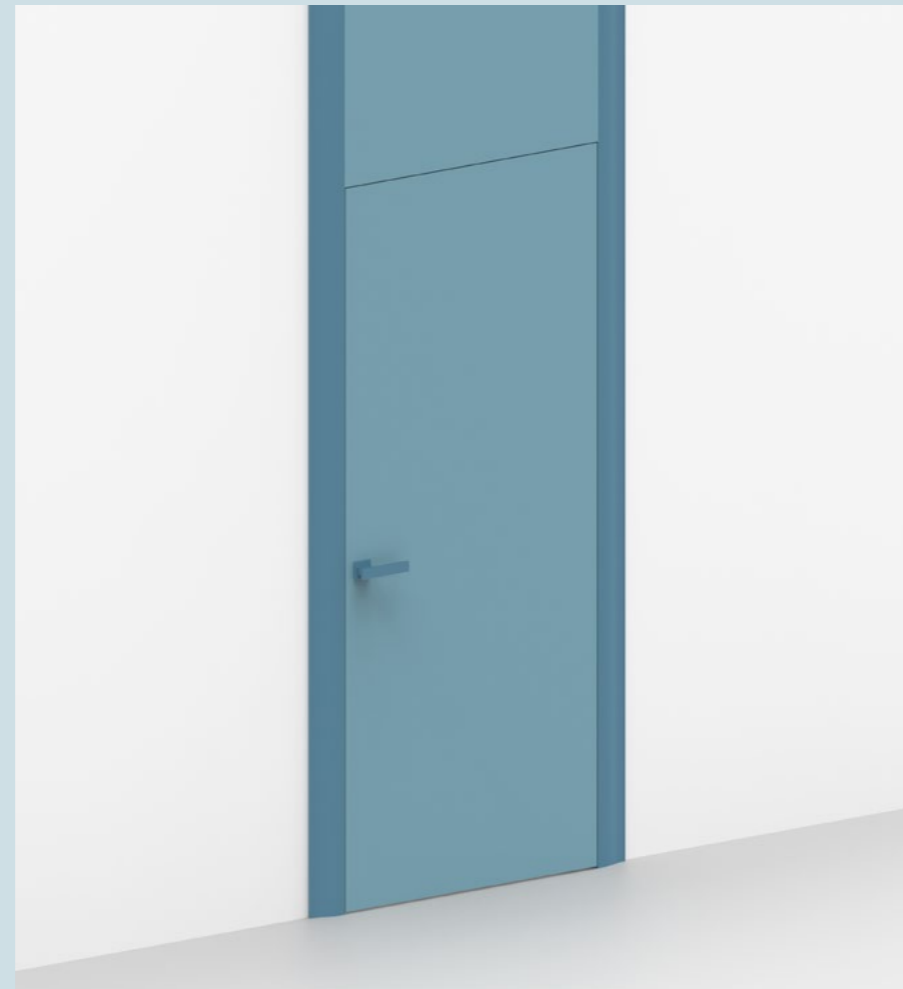

Porta singola a tirare  
Single pull door

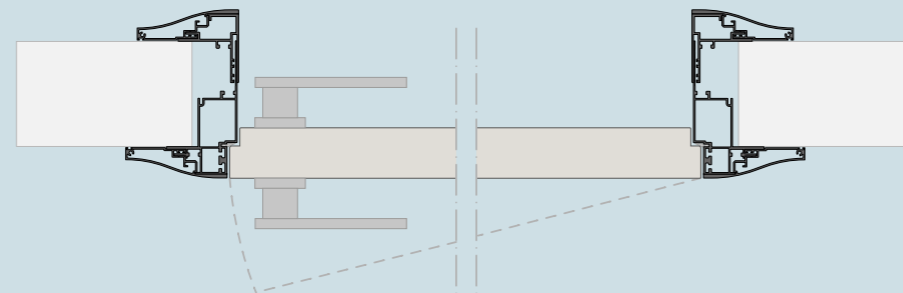

Porta singola a spingere  
Single push door

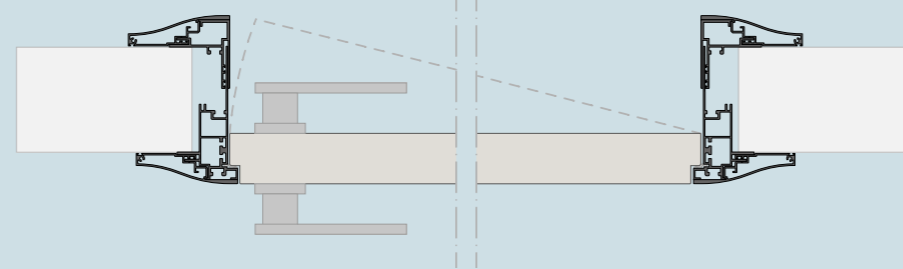

### Porta a due ante / Double door



Porta a due ante asimmetriche a tirare  
Asymmetrical double pull door

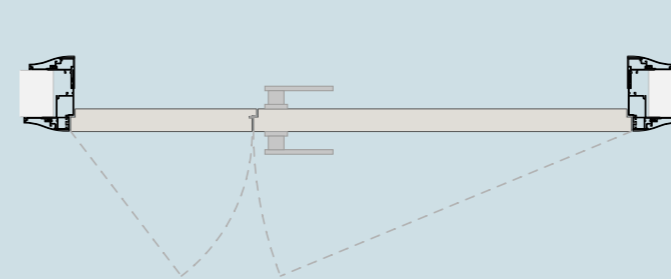

Porta a due ante simmetriche a tirare  
Symmetrical double pull door

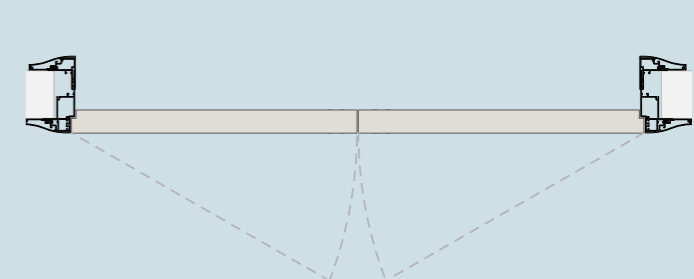

# Stipite Morbida per porte battenti

## Morbida jamb for hinged door

### Compatibilità / Compatibilities

### Dettagli / Details

#### Morbida P. 56

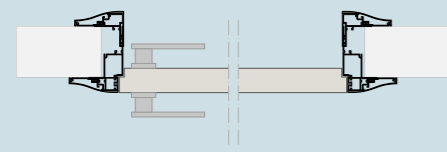

Morbida pannello a tirare  
Morbida panel to pull

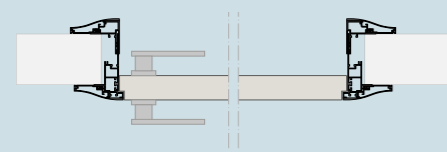

Morbida pannello a spingere  
Morbida panel to push

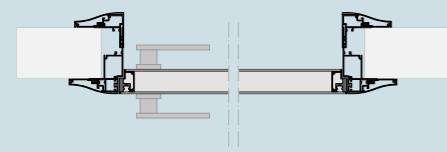

Morbida doppio vetro a tirare  
Morbida double glass to pull

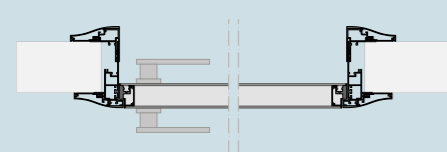

Morbida doppio vetro a spingere  
Morbida double glass to push

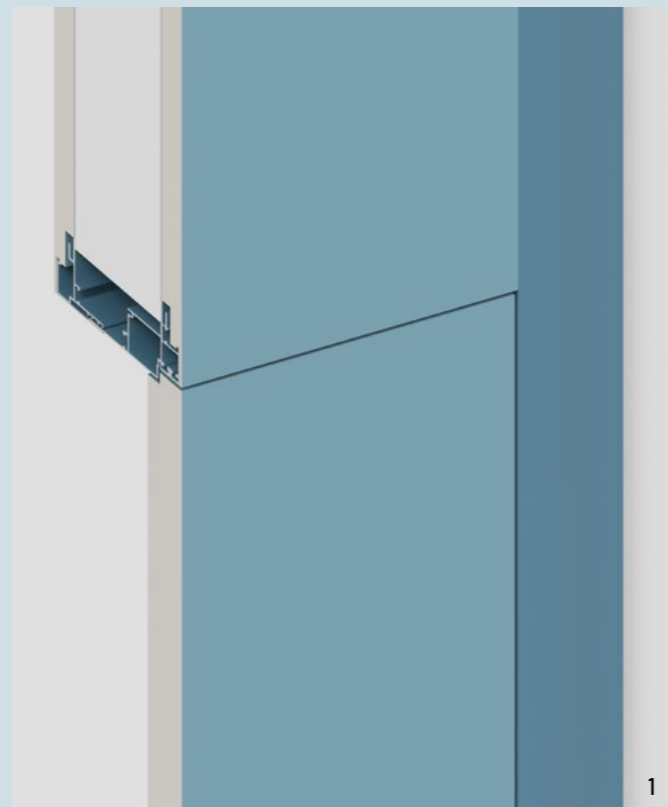

1

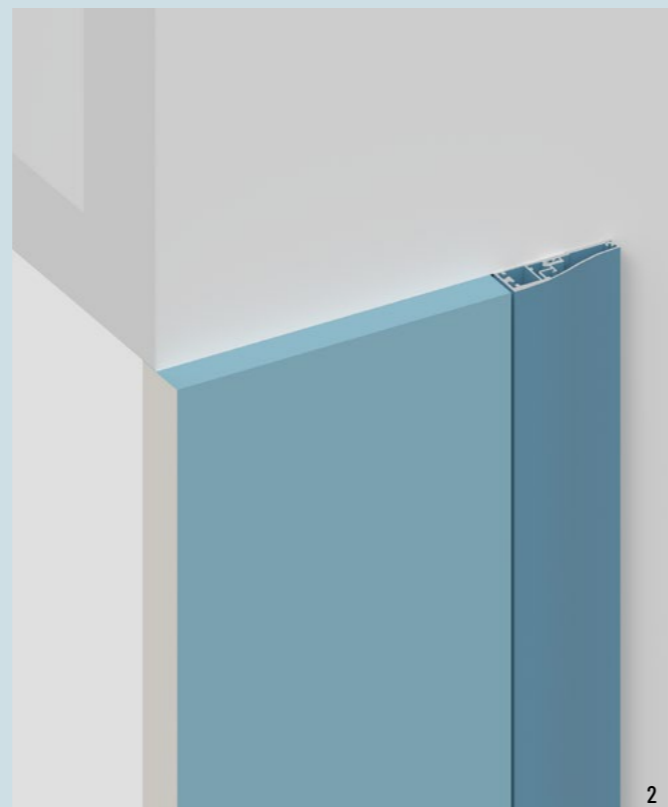

2

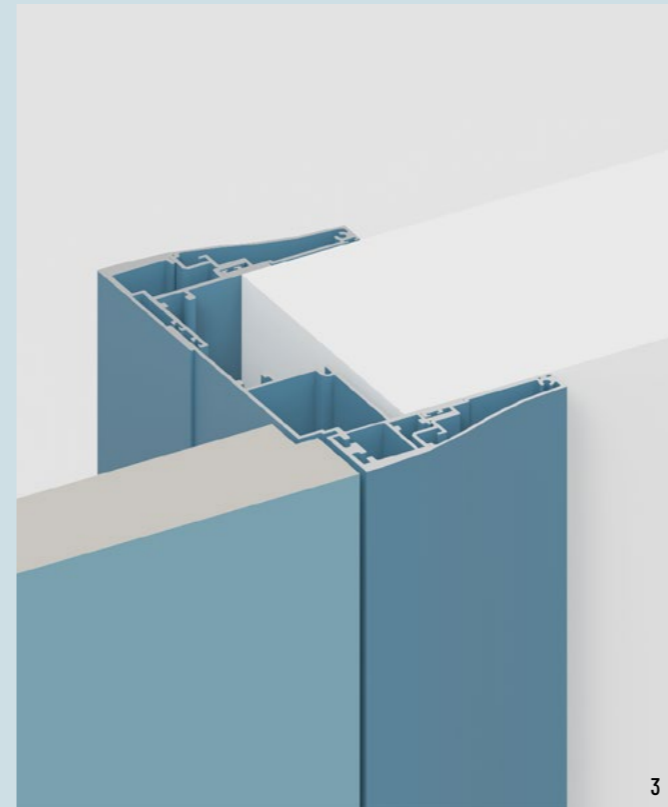

3

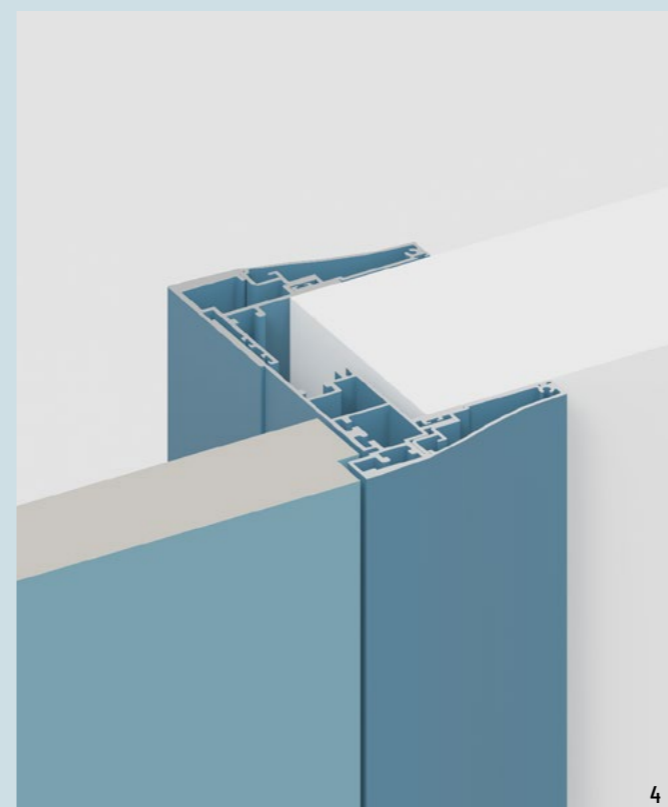

4

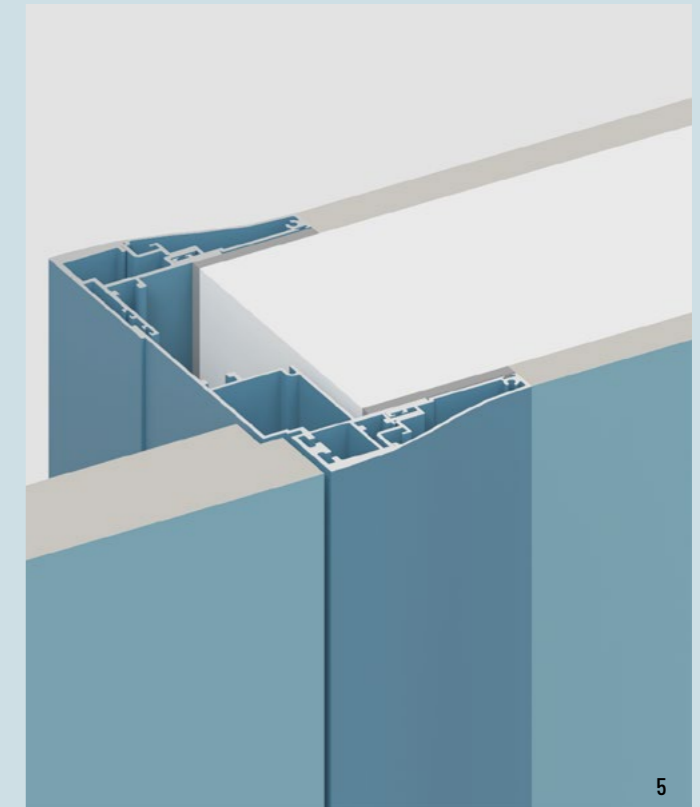

5

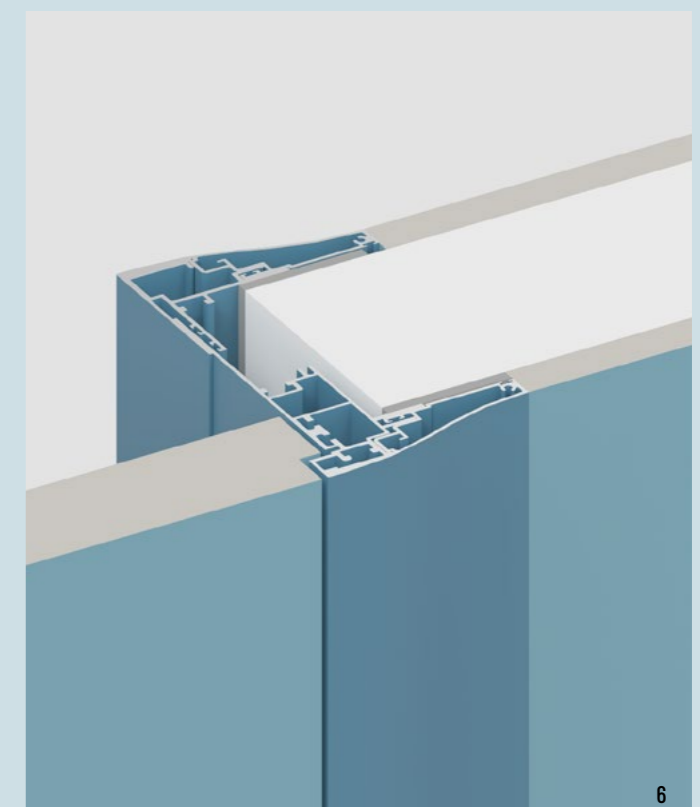

6

1. Sezione verticale stipite e pannello Morbida (stipite su tre lati) a tirare  
1. Vertical section Morbida jamb and panel (jamb on three sides) to pull

2. Sezione verticale stipite e pannello Morbida (tutta altezza) a tirare  
2. Vertical section Morbida jamb and panel (all height) to pull

3. Sezione orizzontale stipite e pannello porta Morbida tirare  
3. Horizontal section Morbida jamb and panel to pull

4. Sezione orizzontale stipite e pannello porta Morbida tirare a spingere  
4. Horizontal section Morbida jamb and panel to push

5. Sezione orizzontale stipite e pannello porta Morbida a spingere con pannelli Boiserie a incollaggio  
5. Horizontal section Morbida jamb and panel to pull with Boiserie gluing panels

6. Sezione orizzontale stipite e pannello porta Morbida a tirare con pannelli Boiserie a incollaggio  
6. Horizontal section Morbida jamb and panel to push with Boiserie gluing panels

Informazioni generali / General informations  
Porte battenti con cornice / Hinged door and frame  
Porte effetto filomuro / Flush-effect door  
Porte filomuro / Flush door  
Porte senza falso telaio / Door w/o basic door frame  
Porte a scomparsa / Pocket door  
Pari scorrevoli o girevoli / Sliding or pivoting panels  
Pari divisorie / Partition wall  
Boiserie / Boiserie  
Cabine armadio / Walk-in closet  
Librerie / Bookcase  
Tavoli / Table

Informazioni generali / General informations  
Porte battenti con cornice / Hinged door and frame  
Porte effetto filomuro / Flush-effect door  
Porte filomuro / Flush door  
Porte senza falso telaio / Door w/o basic door frame  
Porte a scomparsa / Pocket door  
Pari scorrevoli o girevoli / Sliding or pivoting panels  
Pari divisorie / Partition wall  
Boiserie / Boiserie  
Cabine armadio / Walk-in closet  
Librerie / Bookcase  
Tavoli / Table



# Stipite 45° per porte battenti

## Jamb 45° for hinged door

Lo stipite in alluminio tagliato a 45° è una soluzione minimale che interpreta con precisione tecnica e attenzione al dettaglio la classica cornice del vano porta. Si monta su un falso telaio tradizionale ed è adattabile a tutti gli spessori parete da 60mm a 300mm grazie al sistema telescopico integrato e agli aggiustaggi. Ospita delle cerniere esterne a pivot che ne valorizzano le linee essenziali, con un'apertura a 180° dell'anta (a tirare) o a 90° (a spingere). Le cerniere esterne a pivot Albed hanno ottenuto la certificazione Catas per 100.000 cicli di apertura dell'anta a 180°.

The aluminium jamb cut at 45° is the minimal solution that involves technical precision and attention to detail, when it comes to classical framing of door openings. It is fitted into a traditional door frame and can be adapted to suit all wall thicknesses from 60 mm to 300 mm, thanks to the built-in telescopic system and the adjustments. It supports external pivot hinges which enhance its clean lines, with the door opening 180° (pull opening) or 90° (push opening). Albed's external pivot hinges are CATAS certified for 100,000 opening cycles for a 180° door.

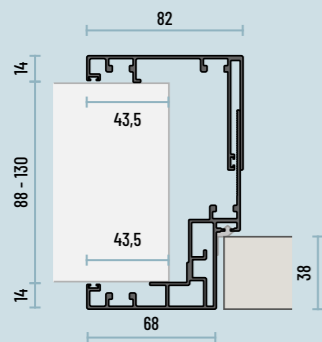

Dimensioni (mm) stipite 45° per porte battenti a tirare  
Dimensions (mm) jamb 45° for pull hinged doors

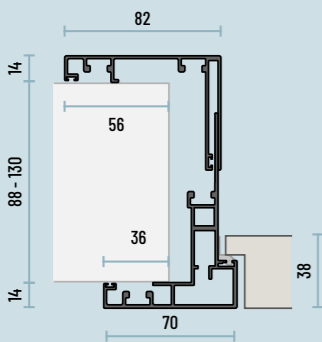

Dimensioni (mm) stipite 45° per porte battenti a spingere  
Dimensions (mm) jamb 45° for push hinged doors

### Porta singola / Single door



Porta singola a tirare  
Single pull door

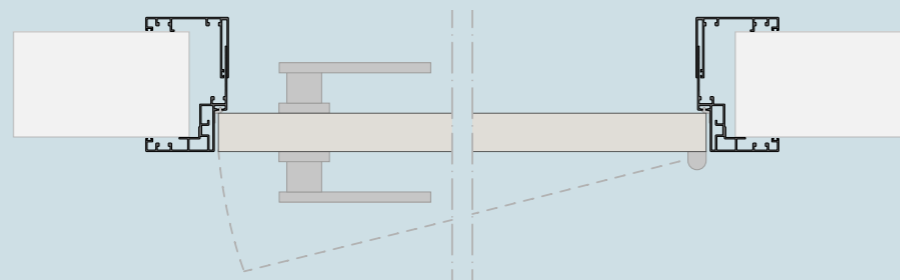

Porta singola a spingere  
Single push door

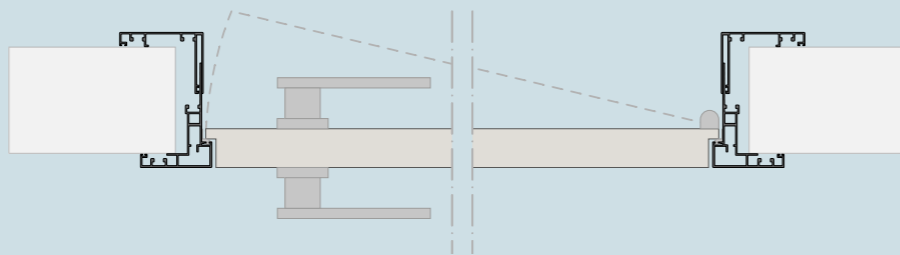

### Porta a due ante / Double door



Porta a due ante asimmetriche a tirare  
Asymmetrical double pull door

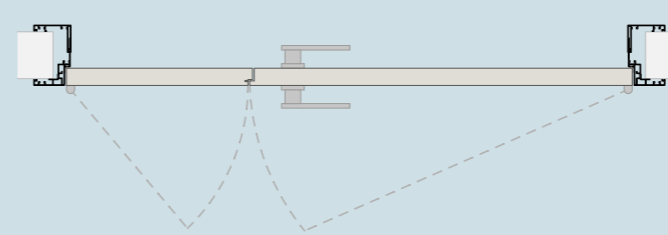

Porta a due ante simmetriche a tirare  
Symmetrical double pull door

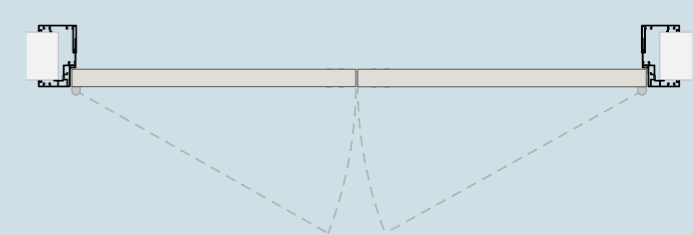

# Stipite 45° per porte battenti Jamb 45° for hinged door

## Compatibilità / Compatibilities

### Quadra P. 70

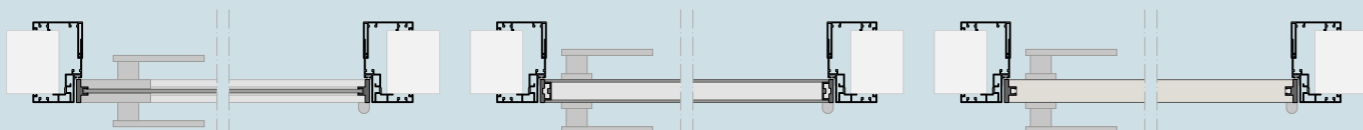

Quadra vetro singolo a tirare  
Quadra single glass to pull

Quadra doppio vetro a tirare  
Quadra double glass to pull

Quadra pannello a tirare  
Quadra panel to pull

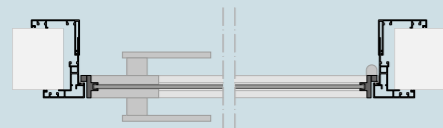

Quadra vetro singolo a spingere  
Quadra single glass to push



Quadra doppio vetro a spingere  
Quadra double glass to push

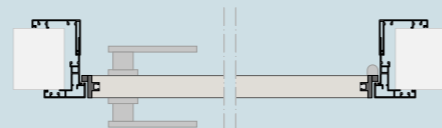

Quadra pannello a spingere  
Quadra panel to push

### Celine P. 74 Ri-trait P. 76



Celine a tirare  
Celine to pull



Ri-trait vetro a tirare  
Ri-trait glass to pull

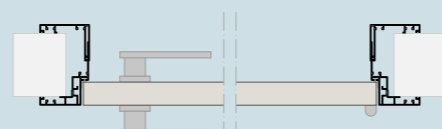

Ri-trait pannello a tirare  
Ri-trait panel to pull



Celine a spingere  
Celine to push

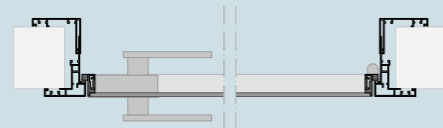

Ri-trait vetro a spingere  
Ri-trait glass to push

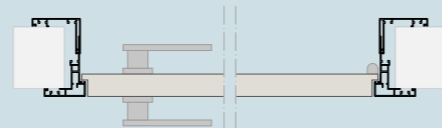

Ri-trait pannello a spingere  
Ri-trait panel to push

### Ring P. 80 Blow P. 81 Quies P. 82

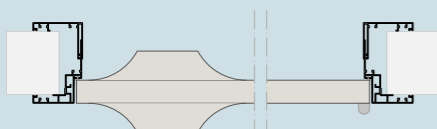

Ring a tirare  
Ring to pull

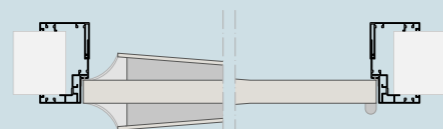

Blow a tirare  
Blow to pull

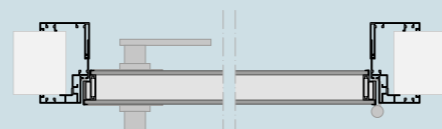

Quies a tirare  
Quies to pull

### Prima P. 72



Prima a tirare  
Prima to pull

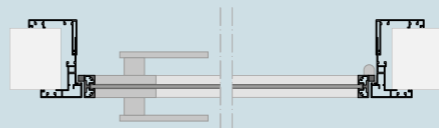

Prima a spingere  
Prima to push

### Ri-trait 8b P. 78



Ri-trait 8b a tirare  
Ri-trait 8b to pull

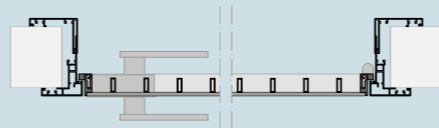

Ri-trait 8b a spingere  
Ri-trait 8b to push

## Dettagli / Details



1

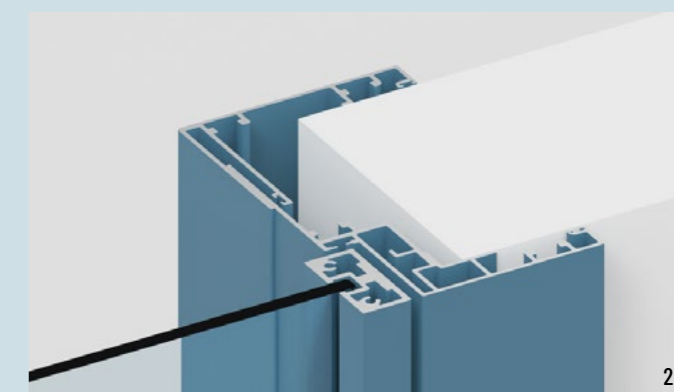

2

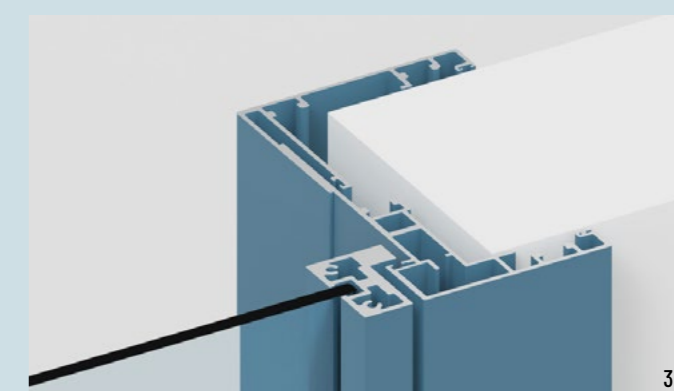

3

1. Sezione verticale Stipite 45° con Prima a tirare  
1. Vertical section Jamb 45° with Prima to pull  
2. Sezione orizzontale Stipite 45° con Prima a tirare  
2. Horizontal section Jamb 45° with Prima to pull  
3. Sezione orizzontale Stipite 45° con Prima a spingere  
3. Horizontal section Jamb 45° with Prima to push

Informazioni generali / General informations  
Porte battenti con cornice / Hinged door and frame  
Porte effetto filomuro / Flush-effect door  
Porte filomuro / Flush door  
Porte senza falso telaio / Door w/o basic door frame  
Porte a scomparsa / Pocket door  
Pani scorrevoli o girevoli / Sliding or pivoting panels  
Pareti divisorie / Partition wall  
Boiserie / Boiserie  
Cabine armadio / Walk-in closet  
Librerie / Bookcase  
Tavoli / Table

Informazioni generali / General informations  
Porte battenti con cornice / Hinged door and frame  
Porte effetto filomuro / Flush-effect door  
Porte filomuro / Flush door  
Porte senza falso telaio / Door w/o basic door frame  
Porte a scomparsa / Pocket door  
Pani scorrevoli o girevoli / Sliding or pivoting panels  
Pareti divisorie / Partition wall  
Boiserie / Boiserie  
Cabine armadio / Walk-in closet  
Librerie / Bookcase  
Tavoli / Table

# Stipite personalizzabile per porte battenti

## Customizable jamb for hinged door

Lo stipite in alluminio personalizzabile di Albed integra un coprifilo in finitura, complanare alla cornice, che permette di customizzare l'estetica dello stipite. Il risultato è la possibilità di giocare con materiali e finiture tra legno, vetro e metalli rispondendo alle più esigenti richieste estetiche. Ospita delle cerniere esterne a pivot che ne valorizzano le linee essenziali, con un'apertura a 180° dell'anta (a tirare) o a 90° (a spingere). Le cerniere esterne a pivot Albed hanno ottenuto la certificazione Catas per 100.000 cicli di apertura dell'anta a 180°.

Albed's customizable aluminium jamb includes a finishing list, flush with the frame, which makes it possible to customize the aesthetics on the jamb. As a result, materials and finishes can be used creatively. Wood, glass, and metal combine to meet the most demanding aesthetic requirements. It supports external pivot hinges which enhance its clean lines, with the door opening 180° (pull opening) or 90° (push opening). Albed's external pivot hinges are CATAS certified for 100,000 opening cycles for a 180° door.

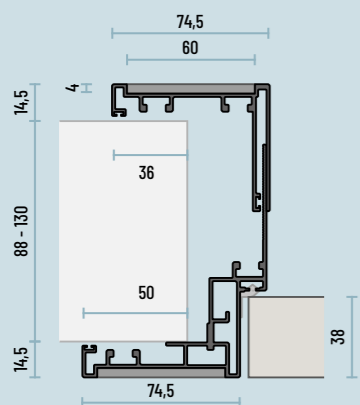

Dimensioni (mm) stipite personaliz. per porte battenti a tirare  
Dimensions (mm) jamb customizable for pull hinged doors

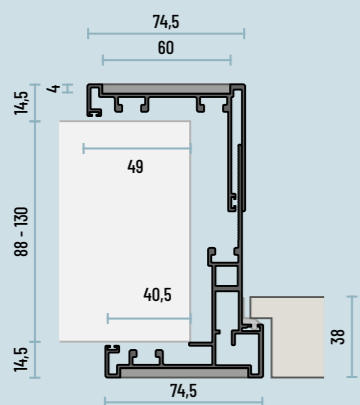

Dimensioni (mm) stipite personaliz. per porte battenti a spingere  
Dimensions (mm) jamb customizable for push hinged doors

### Porta singola / Single door



Porta singola a tirare  
Single pull door

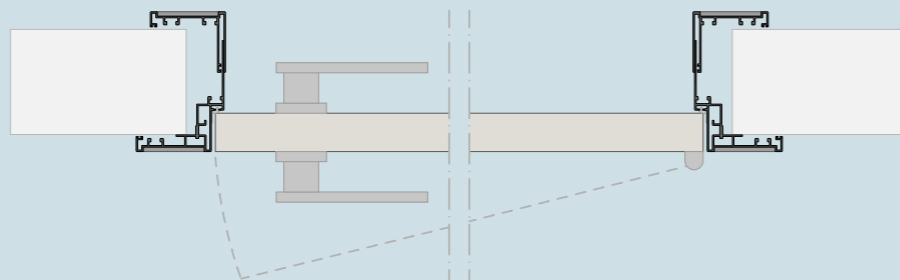

Porta singola a spingere  
Single push door

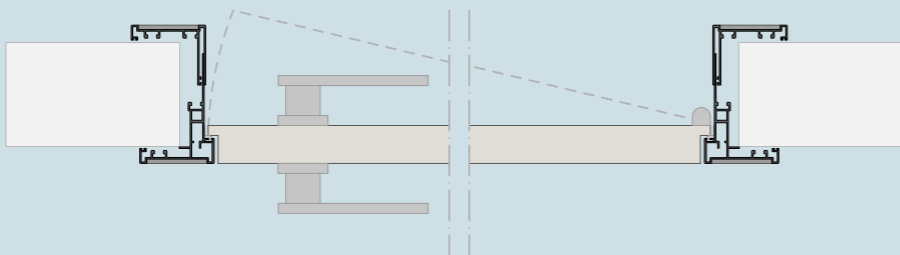

### Porta a due ante / Double door



Porta a due ante asimmetriche a tirare  
Asymmetrical double pull door

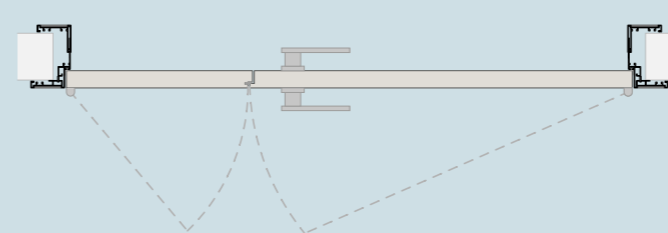

Porta a due ante simmetriche a tirare  
Symmetrical double pull door

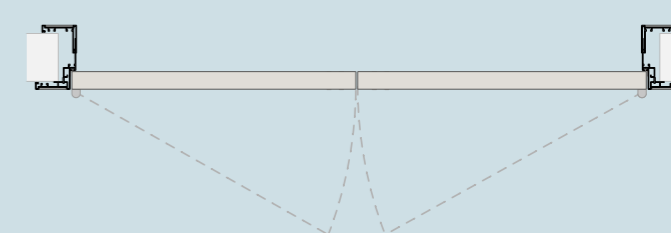



# Stipite personalizzabile per porte battenti

## Customizable jamb for hinged door

### Compatibilità / Compatibilities

#### Quadra P. 70



Quadra vetro singolo a tirare  
Quadra single glass to pull

Quadra doppio vetro a tirare  
Quadra double glass to pull

Quadra pannello a tirare  
Quadra panel to pull

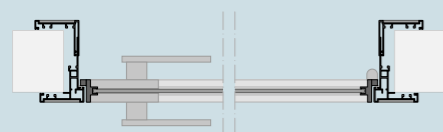

Quadra vetro singolo a spingere  
Quadra single glass to push



Quadra doppio vetro a spingere  
Quadra double glass to push



Quadra pannello a spingere  
Quadra panel to push

#### Celine P. 74

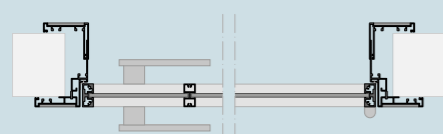

Celine a tirare  
Celine to pull

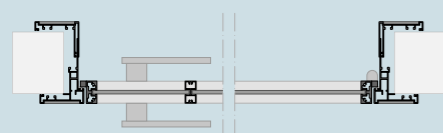

Celine a spingere  
Celine to push

#### Ri-trait P. 76



Ri-trait vetro a tirare  
Ri-trait glass to pull

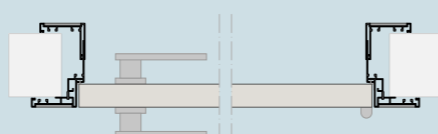

Ri-trait pannello a tirare  
Ri-trait panel to pull

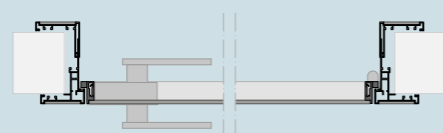

Ri-trait vetro a spingere  
Ri-trait glass to push

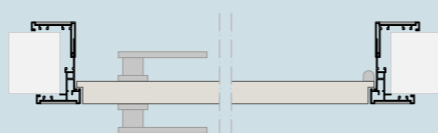

Ri-trait pannello a spingere  
Ri-trait panel to push

#### Ring P. 80

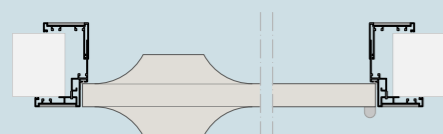

Ring a tirare  
Ring to pull

#### Blow P. 81

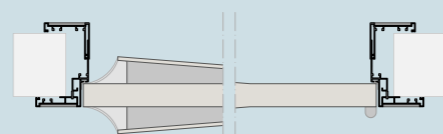

Blow a tirare  
Blow to pull

#### Prima P. 72

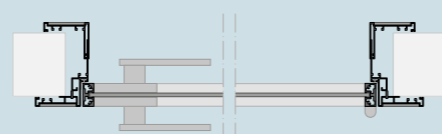

Prima a tirare  
Prima to pull

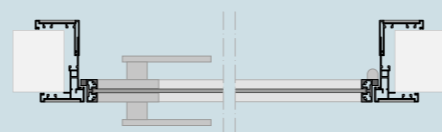

Prima a spingere  
Prima to push

#### Ri-trait 8b P. 78

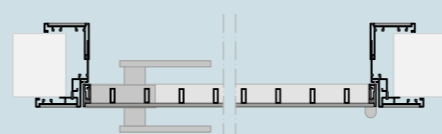

Ri-trait 8b a tirare  
Ri-trait 8b to pull

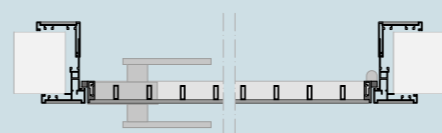

Ri-trait 8b a spingere  
Ri-trait 8b to push

### Dettagli / Details

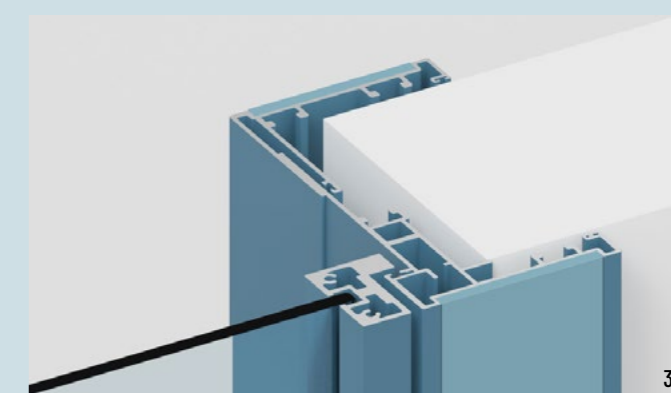
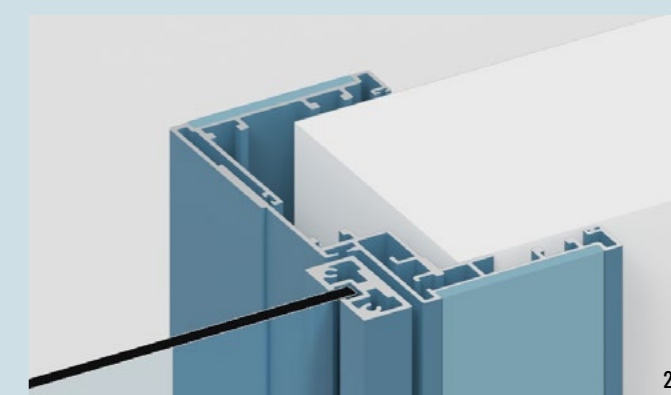

1. Sezione verticale Stipite personaliz. con Prima a tirare  
1. Vertical section Jamb customizable with Prima to pull  
2. Sezione orizzontale Stipite personaliz. con Prima a tirare  
2. Horizontal section Jamb customizable with Prima to pull  
3. Sezione orizzontale Stipite personaliz. con Prima a spingere  
3. Horizontal section Jamb customizable with Prima to push

Informazioni generali / General informations  
Porte battenti con cornice / Hinged door and frame  
Porte effetto filomuro / Flush-effect door  
Porte filomuro / Flush door  
Porte senza falso telaio / Door w/o basic door frame  
Porte a scomparsa / Pocket door  
Pan. scorrevoli o girevoli / Sliding or pivoting panels  
Pareti divisorie / Partition wall  
Boiserie / Boiserie  
Cabine armadio / Walk-in closet  
Librerie / Bookcase  
Tavoli / Table

Informazioni generali / General informations  
Porte battenti con cornice / Hinged door and frame  
Porte effetto filomuro / Flush-effect door  
Porte filomuro / Flush door  
Porte senza falso telaio / Door w/o basic door frame  
Porte a scomparsa / Pocket door  
Pan. scorrevoli o girevoli / Sliding or pivoting panels  
Pareti divisorie / Partition wall  
Boiserie / Boiserie  
Cabine armadio / Walk-in closet  
Librerie / Bookcase  
Tavoli / Table

# Stipite slim per porte battenti

## Slim jamb for hinged door

Lo stipite Slim è un profilo minimale nel quale gli spessori e i dettagli tecnici del sistema porta sono stati ridotti al minimo per ottenere un raffinato inserimento tecnico del pannello porta nella parete. Le sue linee essenziali definiscono una cornice sottilissima attorno al vano porta, che disegna il passaggio. Ospita delle cerniere esterne a pivot che ne valorizzano le linee essenziali, con un'apertura a 180° dell'anta (a tirare). Le cerniere esterne a pivot Albed hanno ottenuto la certificazione Catas per 100.000 cicli di apertura dell'anta a 180°.

The Slim Jamb is an minimal profile in which the door system's thicknesses and technical details are reduced to a minimum to achieve refined technical insertion of the door panel into the wall. Its clean lines define a very slim frame around the door opening, outlining the way through. It supports external pivot hinges which enhance its clean lines, with the door opening 180° (pull opening). Albed's external pivot hinges are CATAS certified for 100,000 opening cycles for a 180° door.

### Porta singola / Single door



Porta singola a tirare  
Single pull door

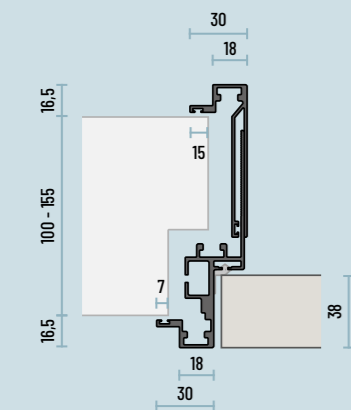
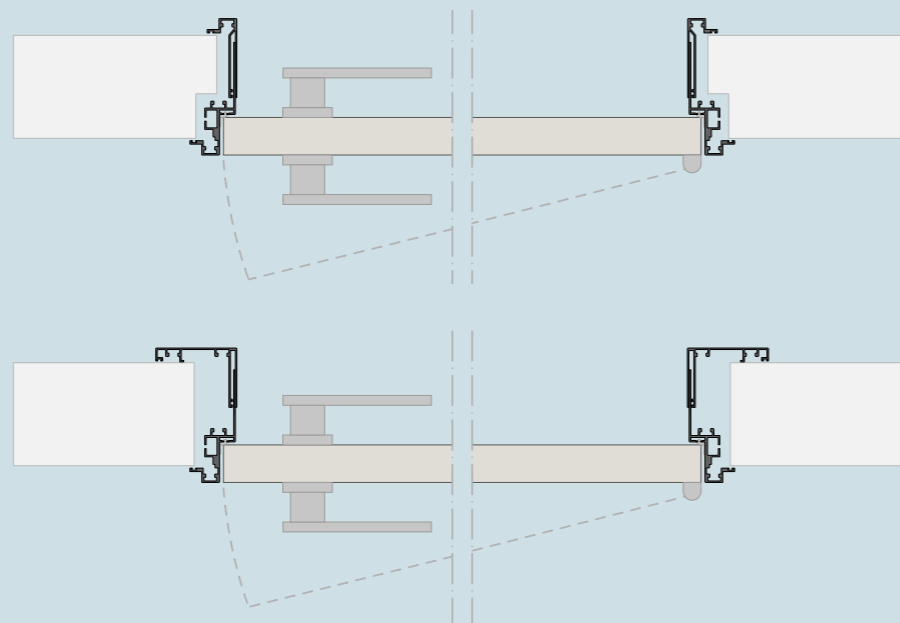

Dimensioni (mm) stipite slim per porte battenti a tirare  
Dimensions (mm) slim jamb for pull hinged doors

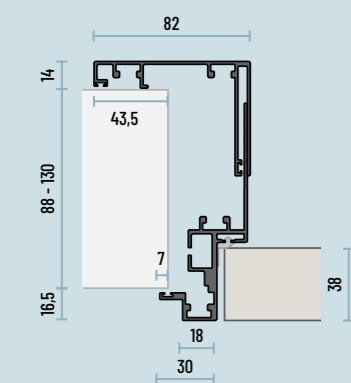

Dimensioni (mm) stipite slim-45° per porte battenti a tirare  
Dimensions (mm) slim-45° jamb for pull hinged doors

### Porta a due ante / Double door



Porta a due ante asimmetriche a tirare  
Asymmetrical double pull door

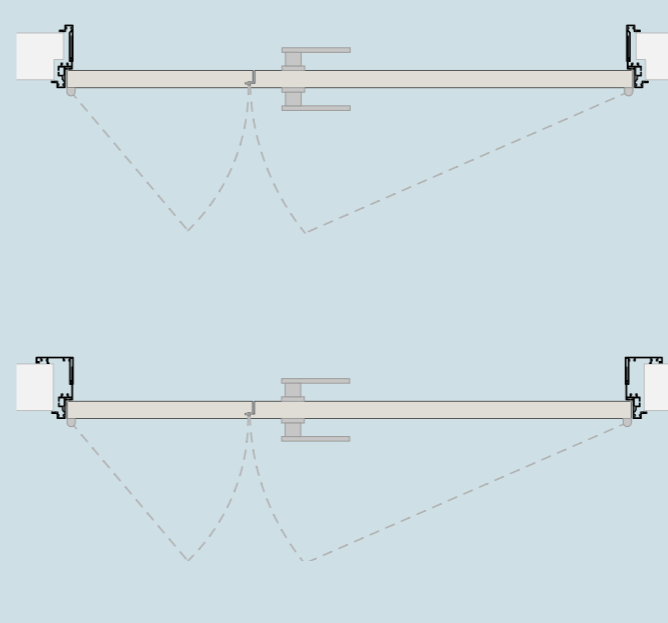

Porta a due ante simmetriche a tirare  
Symmetrical double pull door

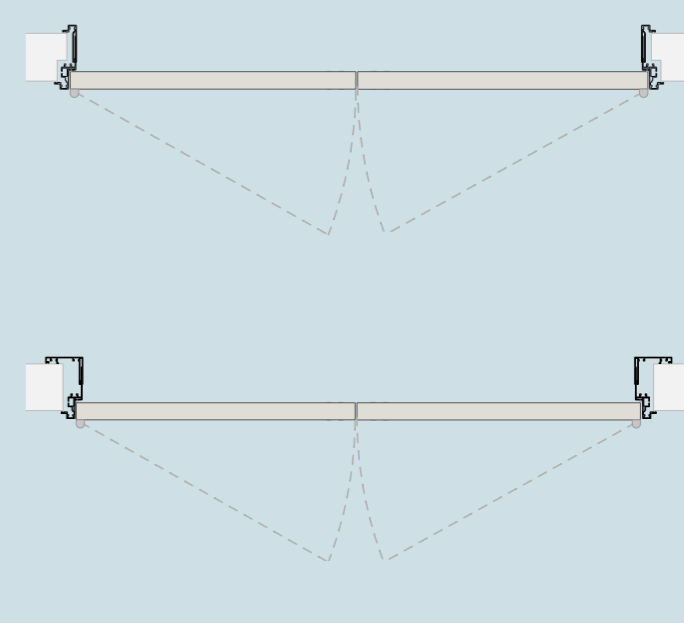

# Stipite slim per porte battenti

## Slim jamb for hinged door

### Compatibilità / Compatibilities

#### Quadra

P. 64

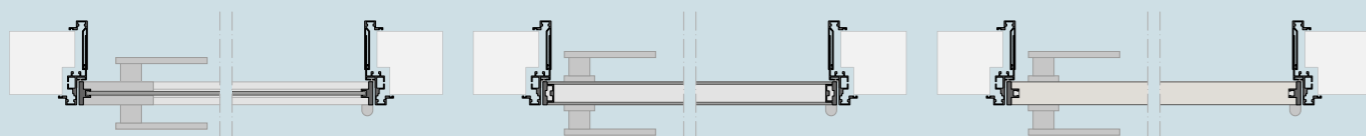

Quadra vetro singolo a tirare  
Quadra single glass to pull

Quadra doppio vetro a tirare  
Quadra double glass to pull

Quadra pannello a tirare  
Quadra panel to pull

#### Prima

P. 66

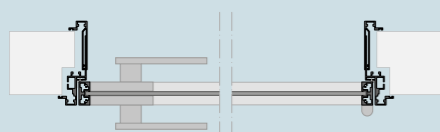

Prima a tirare  
Prima to pull

#### Celine

P. 68

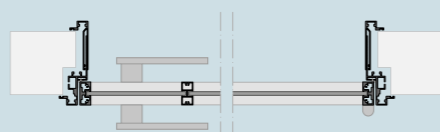

Celine a tirare  
Celine to pull

#### Ri-trait

P. 70



Ri-trait vetro a tirare  
Ri-trait glass to pull

Ri-trait pannello a tirare  
Ri-trait panel to pull

#### Ri-trait 8b

P. 72

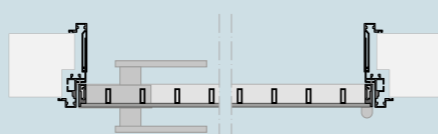

Ri-trait 8b a tirare  
Ri-trait 8b to pull

#### Ring

P. 74

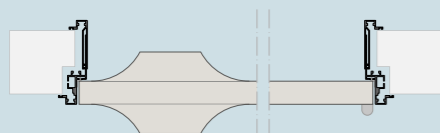

Ring a tirare  
Ring to pull

#### Blow

P. 75

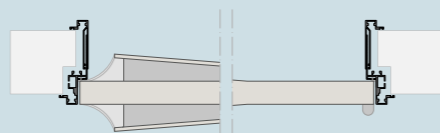

Blow a tirare  
Blow to pull

### Dettagli / Details

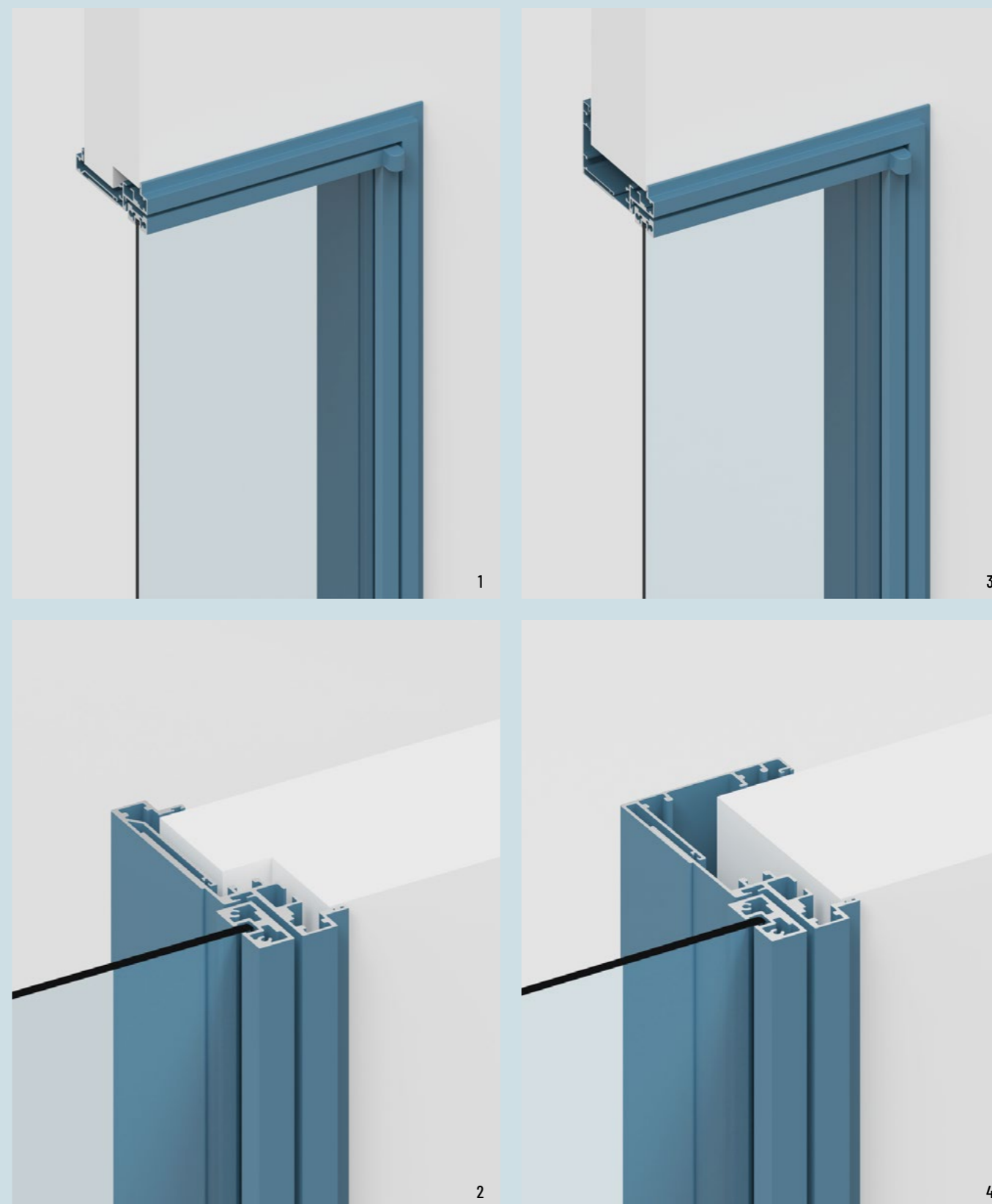

1. Sezione verticale Stipite slim con Prima a tirare  
1. Vertical section Slim jamb with Prima to pull

2. Sezione orizzontale Stipite slim con Prima a tirare  
2. Horizontal section Slim jamb with Prima to pull

3. Sezione verticale Stipite slim anteriore e Stipite 45° posteriore con Prima a tirare  
3. Vertical section Slim jamb on the front and Jamb 45° on the back with Prima to pull

4. Sezione orizzontale Stipite slim anteriore e Stipite 45° posteriore con Prima a tirare  
4. Horizontal section Slim jamb on the front and Jamb 45° on the back with Prima to pull





# Celine battente con cornice

## Celine hinged door and frame

### 1 PORTE SINGOLE STANDARD / STANDARD SINGLE DOORS

Tipo pannello Panel type	Finitura pannello Panel finishing	Finitura stipite e telaio Jamb and frame finishing	Stipite 45° Jamb 45°	Stipite pers.* Cust. jamb*	Stipite slim** Slim jamb**
Vetro Glass	[1][2] <b>Vetro Cat. A</b> Glass Cat. A	<b>Finitura alluminio anodizzato o RAL 9003</b> / Anodized aluminum finishing or RAL 9003	€ 1.420	€ 1.420	€ 1.340
	[3][4] <b>Vetro Cat. A</b> Glass Cat. A	<b>Finitura alluminio anodizzato o RAL 9003</b> / Anodized aluminum finishing or RAL 9003	€ 1.520	€ 1.520	€ 1.440

\* il prezzo non comprende coprifili, ordinare separatamente P. 77 / price does not include finishing lists, order separately P. 77  
 \*\* per versione con Stipite 45° posteriore + € 50 / for version with Jamb 45° on the back + € 50

### DIMENSIONI STANDARD / STANDARD SIZES

Porta singola Single door	Pannelli standard Standard panels	Controtelaio Counterframe
A tirare o a spingere To pull or to push	L 633/733/833 x H 2115	L 690/790/890 ±10 x H 2150 ±10

Al momento dell'ordine specificare il senso di apertura: tirare o spingere e sinistra o destra  
 When ordering, specify the opening side of the door: pull or push and left or right.

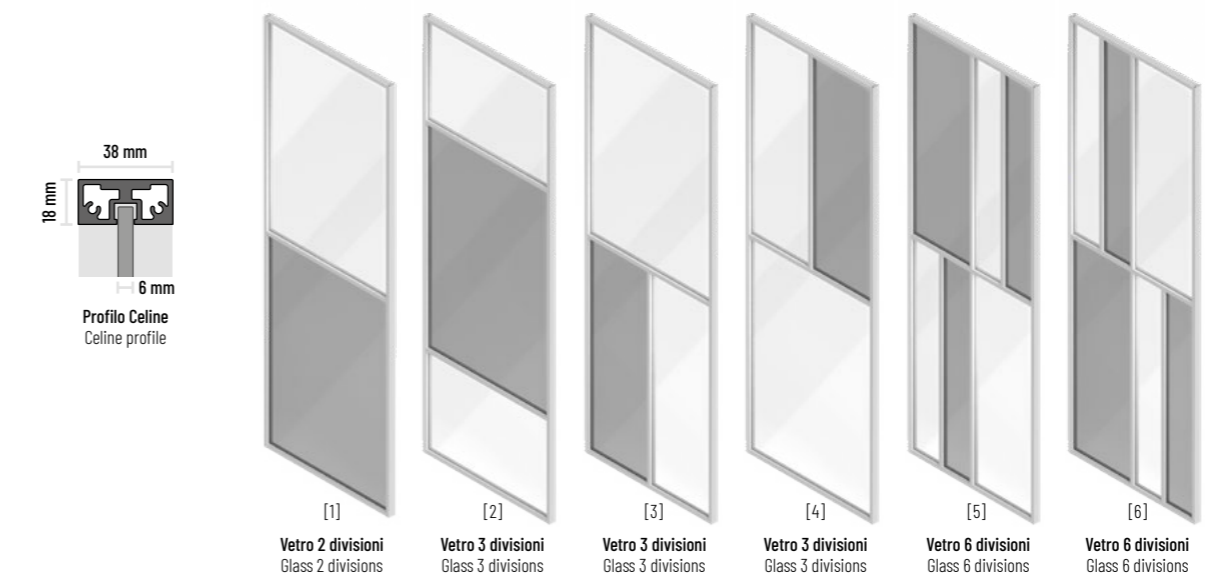

### 2 DIMENSIONI CUSTOM / CUSTOM SIZES

Tipo pannello Panel type	Per controtelaio: For counterframes:	L < 1090 ±10
Vetro Glass	H < 2400 ±10	+ € 75
	H < 2700 ±10	+ € 200
	H < 3000 ±10	+ € 350

Per qualsiasi larghezza custom per controtelaio fino a L 1090 ±10 (per porta singola) o fino a L 2090 ±10 (per porta a due ante)  
 For any custom width for counterframe up to L 1090 ±10 (for single door) or up to L 2090 ±10 (for double door)

### 3 FINITURE / FINISHINGS

Tipo pannello Panel type	Finitura Finishing	P. 30
Vetro Glass	<b>Vetro Cat. B</b> / Glass Cat. B	+ 10%
	<b>Vetro Cat. C</b> / Glass Cat. C	+ 15%
	<b>Vetro Cat. D</b> / Glass Cat. D	+ 45%
	<b>Vetro Cat. E</b> / Glass Cat. E	+ 75%

Specificare 2 finiture diverse per le divisioni del vetro.  
 Specify 2 different finishes for the glass divisions.

In caso di 3 o più finiture diverse sovrapprezzo + 5%  
 In case of 3 or more different finishes, surcharge of + 5%

Per finiture di categorie diverse il prezzo viene calcolato sulla categoria più alta.  
 For finishes of different categories the price is calculated on the highest category.

### 4 PORTE A DUE ANTE / DOUBLE DOORS

Tipo pannello Panel type	Porta a due ante Double door	
Vetro Glass	<b>Due ante asimmetriche</b> Asymmetrical double door	+ 80%
	<b>Due ante simmetriche</b> Symmetrical double door	+ 90%

Porte a due ante disponibili per controtelai da L 1190 ±10 a L 2090 ±10  
 Double doors available for counterframes from L 1190 ±10 to L 2090 ±10

Porta a due ante asimmetriche è formata da un pannello porta L833 + un pannello semifisso di L tale da riempire il controtelaio  
 Symmetrical double door is made up from a door panel L814 + a semi-fixed panel of Width such as to fill the counter frame

Porta a due ante simmetriche è formata da due pannelli di Larghezza uguale  
 Symmetrical double door is made up of two panels of equal Width

### 5 SISTEMI DI CHIUSURA / CLOSING SYSTEMS

Tipo pannello Panel type	Sistema di chiusura Closing system	Senza blocco Whitout block	Nottolino Latch free/busy	Chiave Yale Yale key
Vetro Glass	<b>Serratura integrata con scrocco magnetico</b> Integrated lock with magnetic latch	***	***	***
	<b>Chiusura magnetica senza scrocco<sup>1</sup></b> Magnetic closing without latch <sup>1</sup>	+ € 50	-	-

<sup>1</sup> disponibile solo per Porta a due ante simmetriche.  
 Per questa opzione è necessario ordinare due elementi  
<sup>1</sup> available only for Symmetrical double door.  
 For this option order two elements.

\*\*\* prezzo incluso nella maniglia  
 \*\*\* price included in the handle

### 6 MANIGLIE / HANDLES

Tipo pannello Panel type	Sistema di chiusura Closing system	Maniglia Handle	Solo maniglia Only handle	Nottolino Latch free/busy	Chiave Yale Yale key
Vetro Glass	<b>Serratura integrata con scrocco magnetico</b> Integrated lock with magnetic latch	Etna	+ € 250	+ € 290	+ € 350
		Vesuvio	+ € 270	+ € 300	+ € 370
	<b>Chiusura magnetica senza scrocco</b> Magnetic closing without latch	Vulcano	+ € 250	+ € 290	+ € 350
		Volga	+ € 100	-	-
		Adige 100mm	+ € 100	-	-
		Adige 300mm	+ € 200	-	-

\*Per di porta a due ante simmetriche ordinare due elementi / For Symmetrical double door order two elements  
 \*\* Disponibile solo per porta a due ante / Aviable only for double door

### 7 ACCESSORI STIPITE / JAMBS ACCESSORIES

Stipite Jamb	Accessorio stipite Jamb accessory	Pagina listino Page price book
Stipite 45° Jamb 45°	Aggiustaggi / Adjustments	P. 83
	Rifili / Trims	
Stipite pers. Cust. jamb	Aggiustaggi / Adjustments	P. 83
	Rifili / Trims	
	Coprifili / Finishing lists	
Stipite slim Slim jamb	Aggiustaggi / Adjustments	P. 83
	Rifili / Jamb's cut	

Aggiustaggi e rifili sono necessari quando i muri hanno un range di spessore diverso da 90mm-130mm (per Stipite 45° e Stipite Personalizzabile) o diverso da 100mm-155mm (per Stipite Slim)  
 Adjustments and trims are necessary when the walls have a thickness range different from 90mm-130mm (for Jamb 45° and Customizable Jamb) or different from 100mm-155mm (for Slim Jamb)

### CODICI PORTE / DOORS CODES

Tipo pannello Panel Type	Stipite 45° / Jamb 45°				Stipite personalizzabile / Customizable jamb				Stipite slim / Slim jamb		
	Porta singola / Single door		Porta a due ante / Double door		Porta singola / Single door		Porta a due ante / Double door		Singola / Single	Porta a due ante / Double door	
	Tirare Pull	Spingere Push	Asimmetriche Asymmetrical	Simmetriche Symmetrical	Spingere Push	Tirare Pull	Asimmetriche Asymmetrical	Simmetriche Symmetrical	Tirare Pull	Asimmetriche Asymmetrical	Simmetriche Symmetrical
[1]	CL-P21T	CL-P21S	CEPY001	CEPY007	CL-P11T	CL-P11S	CEPX001	CEPX007	CL-PS21T	CEPZ001	CEPZ007
[2]	CL-P41T	CL-P41S	CEPY002	CEPY008	CL-P31T	CL-P31S	CEPX002	CEPX008	CL-PS41T	CEPZ002	CEPZ008
[3]	CL-P61T	CL-P61S	CEPY003	CEPY009	CL-P51T	CL-P51S	CEPX003	CEPX009	CL-PS61T	CEPZ003	CEPZ009
[4]	CL-P81T	CL-P81S	CEPY004	CEPY010	CL-P71T	CL-P71S	CEPX004	CEPX010	CL-PS81T	CEPZ004	CEPZ010
[5]	CL-P101T	CL-P101S	CEPY005	CEPY011	CL-P91T	CL-P91S	CEPX005	CEPX011	CL-PS101T	CEPZ005	CEPZ011
[6]	CL-P301T	CL-P301S	CEPY006	CEPY012	CL-P201T	CL-P201S	CEPX006	CEPX012	CL-PS-301T	CEPZ006	CEPZ012

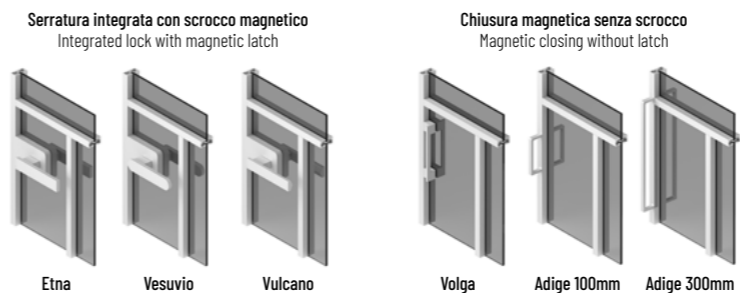

### CODICI SISTEMI DI CHIUSURA / CLOSING SYSTEMS CODES

Sistema di chiusura Closing system	Senza blocco Without block
Chiusura magnetica senza scrocco / Magnetic closing without latch	MT-100

### CODICI MANIGLIE / HANDLES CODES

Maniglia Handle	Solo maniglia Only handle	Nottolino Lacht free/busy	Chiave Yale Yale key
Etna*	PR-PS10	PR-PS20	PR-PS30
Vesuvio*	PR-PS1000	PR-PS2000	PR-PS3000
Vulcano*	PR-PS100	PR-PS200	PR-PS300
Volga	B	-	-
Adige 100mm	RX	-	-
Adige 300mm	R2X	-	-

\*Maniglia con serratura integrata scrocco magn. / Maniglia with integrated lock with magnetic latch

Informazioni generali / General informations  
 Porte battenti con cornice / Hinged door and frame  
 Porte effetto filomuro / Flush-effect door  
 Porte filomuro / Flush door  
 Porte senza falso telaio / Door w/o basic door frame  
 Porte a scomparsa / Pocket door  
 Pannelli scorrevoli o girevoli / Sliding or pivoting panels  
 Pannelli divisorie / Partition wall  
 Boiserie / Bouserie  
 Cabine armadio / Walk-in closet  
 Librerie / Bookcase  
 Tavoli / Table

Informazioni generali / General informations  
 Porte battenti con cornice / Hinged door and frame  
 Porte effetto filomuro / Flush-effect door  
 Porte filomuro / Flush door  
 Porte senza falso telaio / Door w/o basic door frame  
 Porte a scomparsa / Pocket door  
 Pannelli scorrevoli o girevoli / Sliding or pivoting panels  
 Pannelli divisorie / Partition wall  
 Boiserie / Bouserie  
 Cabine armadio / Walk-in closet  
 Librerie / Bookcase  
 Tavoli / Table



# Ri-trait 8b battente con cornice

## Ri-trait 8b hinged door and frame

### 1 PORTE SINGOLE STANDARD / STANDARD SINGLE DOORS

Tipo pannello Panel type	Finitura pannello Panel finishing	Finitura stipite e telaio Jamb and frame finishing	Stipite 45° Jamb 45°	Stipite pers.* Cust. jamb*	Stipite slim** Slim jamb**	
Vetro Glass	[1][2] [3][4]	Vetro Cat. A Glass Cat. A	Finitura alluminio anodizzato Anodized aluminum finishing	€ 1.950	€ 1.950	€ 1.870

\* il prezzo non comprende coprifili, ordinare separatamente P. 77 / price does not include finishing lists, order separately P. 77

\*\* per versione con Stipite 45° posteriore + € 50 / for version with Jamb 45° on the back + € 50

### DIMENSIONI STANDARD / STANDARD SIZES

Porta singola Single door	Pannelli standard Standard panels	Controtelaio Counterframe
A tirare o a spingere To pull or to push	L 633/733/833 x H 2115	L 690/790/890 ±10 x H 2150 ±10

Al momento dell'ordine specificare il senso di apertura: tirare o spingere e sinistra o destra  
When ordering, specify the opening side of the door: pull or push and left or right.

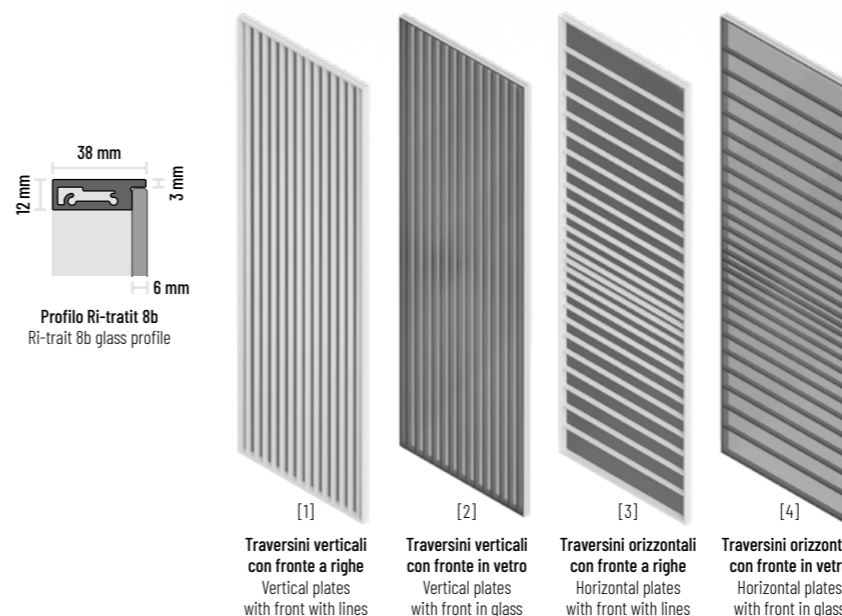

### 2 DIMENSIONI CUSTOM / CUSTOM SIZES

Tipo pannello Panel type	Per controtelaio: For counterframes:	L < 1090 ±10
Vetro Glass	H < 2400 ±10	+ € 220
	H < 2700 ±10	+ € 360
	H < 3000 ±10	+ € 550

Per qualsiasi larghezza custom per controtelaio fino a L 1090 ±10 (per porta singola) o fino a L 2090 ±10 (per porta a due ante)  
For any custom width for counterframe up to L 1090 ±10 (for single door) or up to L 2090 ±10 (for double door)

### 3 FINITURE / FINISHINGS

Tipo pannello Panel type	Finitura Finishing	P. 30
Vetro Glass	Vetro Cat. B / Glass Cat. B	+ 10%
	Vetro Cat. C / Glass Cat. C	+ 15%
	Vetro Cat. D / Glass Cat. D	+ 45%

### 4 PORTE A DUE ANTE / DOUBLE DOORS

Tipo pannello Panel type	Porta a due ante Double door	
Vetro Glass	Due ante asimmetriche Asymmetrical double door	+ 80%
	Due ante simmetriche Symmetrical double door	+ 90%

Porta a due ante disponibili per controtelai da L 1190 ±10 a L 2090 ±10  
Double doors available for counterframes from L 1190 ±10 to L 2090 ±10

Porta a due ante asimmetriche è formata da un pannello porta L833 + un pannello semifisso di L tale da riempire il controtelaio  
Symmetrical double door is made up from a door panel L814 + a semi-fixed panel of Width such as to fill the counter frame

Porta a due ante simmetriche è formata da due pannelli di Larghezza uguale  
Symmetrical double door is made up of two panels of equal Width

### 5 SISTEMI DI CHIUSURA / CLOSING SYSTEMS

Tipo pannello Panel type	Sistema di chiusura Closing system	Senza blocco Without block	Chiave Patent Patent key	Nottolino Latch free/busy	Chiave Yale Yale key
Vetro Glass	Serratura integrata con scrocco magnetico Integrated lock with magnetic latch		***	***	***
	Chiusura magnetica senza scrocco <sup>1</sup> Magnetic closing without latch <sup>1</sup>	+ € 50	-	-	-

<sup>1</sup> disponibile solo per Porta a due ante simmetriche.  
Per questa opzione è necessario ordinare due elementi  
<sup>1</sup> available only for Symmetrical double door.  
For this option order two elements.

\*\*\* prezzo incluso nella maniglia  
\*\*\* price included in the handle

### 6 MANIGLIE / HANDLES

Tipo pannello Panel type	Sistema di chiusura Closing system	Maniglia Handle	Solo maniglia Only handle	Chiave Patent Patent key	Nottolino Latch free/busy	Chiave Yale Yale key
Vetro Glass	Serratura integrata con scrocco magnetico Integrated lock with magnetic latch	Etna Vesuvio Vulcano	Etna Vesuvio Vulcano	+ € 250 + € 270 + € 250	+ € 290 + € 300 + € 290	+ € 350 + € 370 + € 350
	Chiusura magn. snz scrocco Magnetic closing without latch	Adige 200mm*	Adige 200mm*	+ € 100	-	-

\*Per Porta a due ante simmetriche ordinare due elementi / For Symmetrical double door order two elements

### 7 ACCESSORI STIPITE / JAMBS ACCESSORIES

Stipite Jamb	Accessorio stipite Jamb accessory	Pagina listino Page price book
Stipite 45° Jamb 45°	Aggiustaggi / Adjustments Rifili / Trims	P. 83
Stipite pers. Cust. jamb	Aggiustaggi / Adjustments Rifili / Trims Coprifili / Finishing lists	P. 83
Stipite slim Slim jamb	Aggiustaggi / Adjustments Rifili / Jamb's cut	P. 83

Aggiustaggi e rifili sono necessari quando i muri hanno un range di spessore diverso da 90mm-130mm (per Stipite 45° e Stipite Personalizzabile) o diverso da 100mm-155mm (per Stipite Slim)  
Adjustments and trims are necessary when the walls have a thickness range different from 90mm-130mm (for Jamb 45° and Customizable Jamb) or different from 100mm-155mm (for Slim Jamb)

### CODICI PORTE / DOORS CODES

Tipo pannello Panel Type	Stipite 45° / Jamb 45°				Stipite personalizzabile / Customizable jamb				Stipite slim / Slim jamb		
	Porta singola / Single door		Porta a due ante / Double door		Porta singola / Single door		Porta a due ante / Double door		Singola / Single	Porta a due ante / Double door	
	Tirare Pull	Spingere Push	Asimmetriche Asymmetrical	Simmetriche Symmetrical	Spingere Push	Tirare Pull	Asimmetriche Asymmetrical	Simmetriche Symmetrical	Tirare Pull	Asimmetriche Asymmetrical	Simmetriche Symmetrical
[1]	TR-8BV-P5T-R	TR-8BV-P5S-R	R8PY001	R8PY005	TR-8BV-P1T-R	TR-8BV-P1S-R	R8PX001	R8PX005	TR-8BV-PS5T-R	R8PZ001	R8PZ005
[2]	TR-8BV-P5T-V	TR-8BV-P5S-V	R8PY002	R8PY006	TR-8BV-P1T-V	TR-8BV-P1S-V	R8PX002	R8PX006	TR-8BV-PS5T-V	R8PZ002	R8PZ006
[3]	TR-8BH-P5T-R	TR-8BH-P5S-R	R8PY003	R8PY007	TR-8BH-P1T-R	TR-8BH-P1S-R	R8PX003	R8PX007	TR-8BH-PS5T-R	R8PZ003	R8PZ007
[4]	TR-8BH-P5T-V	TR-8BH-P5S-V	R8PY004	R8PY008	TR-8BH-P1T-V	TR-8BH-P1S-V	R8PX004	R8PX008	TR-8BH-PS5T-V	R8PZ004	R8PZ008

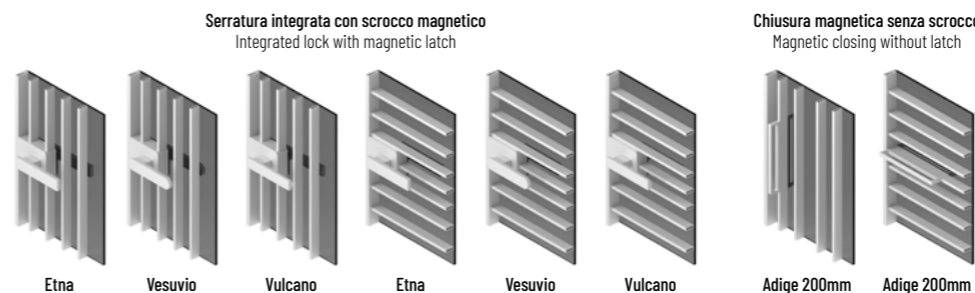

### CODICI SISTEMI DI CHIUSURA / CLOSING SYSTEMS CODES

Sistema di chiusura Closing system	Senza blocco Without block
Chiusura magnetica senza scrocco Magnetic closing without latch	MT-100

### CODICI MANIGLIE / HANDLES CODES

Maniglia Handle	Solo maniglia Only handle	Chiave Patent Patent key	Nottolino Latch free/busy	Chiave Yale Yale key
Etna*	RT-FM4	-	RT-FM5	RT-FM6
Vesuvio*	RT-FM400	-	RT-FM500	RT-FM600
Vulcano*	RT-FM40	-	RT-FM50	RT-FM60
Adige 200mm	MX	-	-	-

\*Maniglia con serratura integrata scrocco magn. / Maniglia with integrated lock with magnetic latch



# Ring battente con cornice

## Ring hinged door and frame

### 1 PORTE SINGOLE STANDARD / STANDARD SINGLE DOORS

Tipo pannello Panel type	Finitura pannello Panel finishing	Finitura stipite Jamb finishing	Stipite 45° Jamb 45°	Stipite pers.* Cust. jamb*	Stipite slim** Slim jamb**
Pannello legno Wooden panel	Laccato standard Standard lacquered	Finitura alluminio anodizzato Anodized aluminum finishing	€ 3.500	€ 3.500	€ 3.400

\* il prezzo non comprende coprifili, ordinare separatamente P. 77 / price does not include finishing lists, order separately P. 77

\*\* per versione con Stipite 45° posteriore + € 50 / for version with Jamb 45° on the back + € 50

### DIMENSIONI STANDARD / STANDARD SIZES

Porta singola Single door	Pannelli standard Standard panels	Controtelaio Counterframe
A tirare To pull or	L 633/733/833 x H 2115	L 690/790/890 ±10 x H 2150 ±10

Al momento dell'ordine specificare il senso di apertura:  
sinistra o destra.

When ordering, specify the opening side of the door:  
left or right.



Pannello Ring  
Ring panel

### 2 DIMENSIONI CUSTOM / CUSTOM SIZES

Tipo pannello Panel type	Per controtelaio: For counterframes:	L < 1090 ±10
Pannello legno Wooden panel	H < 2200 ±10	+ € 100

Per qualsiasi larghezza custom per controtelaio fino a L 1090 ±10  
For any custom width for counterframe up to L 1090 ±10

### 3 FINITURE / FINISHINGS

Tipo pannello Panel type	Finitura Finishing	P. 30
Pannello legno Wooden panel	Laccato custom RAL opaco Custom RAL matte lacquered	+ € 200
	Laccato custom RAL lucido Custom RAL glossy lacquered	+ € 1.000

### 4 SISTEMI DI CHIUSURA / CLOSING SYSTEMS

Tipo pannello Panel type	Sistema di chiusura Closing system	Senza blocco Whitout block	Chiave Patent Patent key	Nottolino Latch free/busy
Pannello legno Wooden panel	Serratura integrata con scrocco magnetico Integrated lock with magnetic latch	+ € 100	+ € 250	+ € 250

### 5 ACCESSORI STIPITE / JAMBS ACCESSORIES

Stipite Jamb	Accessorio stipite Jamb accessory	Pagina listino Page price book
Stipite 45° Jamb 45°	Aggiustaggi / Adjustments Rifili / Trims	P. 83
Stipite pers. Cust. jamb	Aggiustaggi / Adjustments Rifili / Trims Coprifili / Finishing lists	P. 83
Stipite slim Slim jamb	Aggiustaggi / Adjustments Rifili / Jamb's cut	P. 83

Aggiustaggi e rifili sono necessari quando i muri hanno un range di spessore diverso da 90mm-130mm (per Stipite 45° e Stipite Personalizzabile) o diverso da 100mm-155mm (per Stipite Slim)  
Adjustments and trims are necessary when the walls have a thickness range different from 90mm-130mm (for Jamb 45° and Customizable Jamb) or different from 100mm-155mm (for Slim Jamb)

### CODICI PORTE / DOORS CODES

Tipo pannello e sistema di chiusura Tipo pannello e sistema di chiusura	Stipite 45° Jamb 45°	Stipite pers. Cust. jamb	Stipite slim Slim jamb
	Porta singola a tirare Single door to pull	Porta singola a tirare Single door to pull	Porta singola a tirare Single door to pull
Pannello Ring Ring panel	Serratura int. senza blocco / Int. lock without block	KR-RING-P10	RGPZ001
	Serratura int. con nottolino / Int. lock with latch free/busy	KR-RING-P30	RGPZ002
	Serratura int. per chiave Patent / Int. lock with Patent key	KR-RING-P20	RGPZ003

# Blow battente con cornice

## Blow hinged door and frame

### 1 PORTE SINGOLE STANDARD / STANDARD SINGLE DOORS

Tipo pannello Panel type	Finitura pannello Panel finishing	Finitura stipite Jamb finishing	Stipite 45° Jamb 45°	Stipite pers.* Cust. jamb*	Stipite slim** Slim jamb**
Pannello legno Wooden panel	Laccato standard Standard lacquered	Finitura alluminio anodizzato Anodized aluminum finishing	€ 3.700	€ 3.700	€ 3.600

\* il prezzo non comprende coprifili, ordinare separatamente P. 77 / price does not include finishing lists, order separately P. 77

\*\* per versione con Stipite 45° posteriore + € 50 / for version with Jamb 45° on the back + € 50

### DIMENSIONI STANDARD / STANDARD SIZES

Porta singola Single door	Pannelli standard Standard panels	Controtelaio Counterframe
A tirare To pull	L 633/733/833 x H 2115	L 690/790/890 ±10 x H 2150 ±10

Al momento dell'ordine specificare il senso di apertura:  
sinistra o destra.

When ordering, specify the opening side of the door:  
left or right.



Pannello Blow  
Blow panel

### 2 DIMENSIONI CUSTOM / CUSTOM SIZES

Tipo pannello Panel type	Per controtelaio: For counterframes:	L < 1090 ±10
Pannello legno Wooden panel	H < 2200 ±10	+ € 100

Per qualsiasi larghezza custom per controtelaio fino a L 1090 ±10  
For any custom width for counterframe up to L 1090 ±10

### 3 FINITURE / FINISHINGS

Tipo pannello Panel type	Finitura Finishing	P. 30
Pannello legno Wooden panel	Laccato custom RAL opaco Custom RAL matte lacquered	+ € 200
	Laccato custom RAL lucido Custom RAL glossy lacquered	+ € 700
	Rivestimento acrilico bianco White acrylic coating	+ € 500
	Essenza legno Wooden essence	+ € 500

### 4 SISTEMI DI CHIUSURA / CLOSING SYSTEMS

Tipo pannello Panel type	Sistema di chiusura Closing system	Senza blocco Whitout block	Chiave Patent Patent key	Nottolino Latch free/busy
Pannello Panel	Serratura integrata con scrocco magnetico Integrated lock with magnetic latch	+ € 100	+ € 250	+ € 250

### 5 ACCESSORI STIPITE / JAMBS ACCESSORIES

Stipite Jamb	Accessorio stipite Jamb accessory	Pagina listino Page price book
Stipite 45° Jamb 45°	Aggiustaggi / Adjustments Rifili / Trims	P. 83
Stipite pers. Cust. jamb	Aggiustaggi / Adjustments Rifili / Trims Coprifili / Finishing lists	P. 83
Stipite slim Slim jamb	Aggiustaggi / Adjustments Rifili / Jamb's cut	P. 83

Aggiustaggi e rifili sono necessari quando i muri hanno un range di spessore diverso da 90mm-130mm (per Stipite 45° e Stipite Personalizzabile) o diverso da 100mm-155mm (per Stipite Slim)  
Adjustments and trims are necessary when the walls have a thickness range different from 90mm-130mm (for Jamb 45° and Customizable Jamb) or different from 100mm-155mm (for Slim Jamb)

### CODICI PORTE / DOORS CODES

Tipo pannello e sistema di chiusura Tipo pannello e sistema di chiusura	Stipite 45° Jamb 45°	Stipite pers. Cust. jamb	Stipite slim Slim jamb
	Porta singola a tirare Single door to pull	Porta singola a tirare Single door to pull	Porta singola a tirare Single door to pull
Pannello Blow Blow panel	Serratura int. senza blocco / Int. lock without block	KR-BLOW-P10	BWPZ001
	Serratura int. con nottolino / Int. lock with latch free/busy	KR-BLOW-P30	BWPZ002
	Serratura int. per chiave Patent / Int. lock with Patent key	KR-BLOW-P20	BWPZ003

# Quies battente con cornice

## Quies hinged door and frame

### 1 PORTE SINGOLE STD / STD SINGLE DOORS

Tipo pannello Panel type	Finitura pannello Panel finishing	Finitura stipite e telaio Jamb and frame finishing	Stipite 45° Jamb 45°
Doppio vetro Double Glass	Vetro Cat. A Glass Cat. A	Finitura alluminio anodizzato Anodized aluminum finishing	€ 2.350

### 2 DIMENSIONI CUSTOM / CUSTOM SIZES

Tipo pannello Panel type	Per controtelaio: For counterframes:	L < 1090 ±10
Doppio vetro Double Glass	H < 2400 ±10	+ € 250
	H < 2700 ±10	+ € 500

Per qualsiasi larghezza custom per controtelaio fino a L 1090 ±10  
For any custom width for counterframe up to L 1090 ±10

### 3 FINITURE / FINISHINGS

Tipo pannello Panel type	Finitura Finishing	P. 30
Doppio vetro Double Glass	Vetro Cat. B / Glass Cat. B	+ 5%
	Vetro Cat. C / Glass Cat. C	+ 15%
	Vetro Cat. D / Glass Cat. D	+ 45%

### 4 SISTEMI DI CHIUSURA E MANIGLIE / CLOSING SYSTEMS AND HANDLES

Tipo pannello Panel type	Sistema di chiusura Closing system	Maniglia Handle	Solo maniglia Only handle	Nottolino Latch free/busy	Chiave Yale Yale key
Doppio vetro Double Glass	Serratura integrata con scrocco magnetico Integrated lock with magnetic latch	Etna	+ € 250	+ € 290	+ € 350
		Vesuvio	+ € 270	+ € 300	+ € 370
		Vulcano	+ € 250	+ € 290	+ € 350

### 5 ACCESSORI PORTA / DOOR ACCESSORIES

Tipo pannello Panel type	Accessori Accessories	
Doppio vetro Double Glass	Chiudiporta integrato / Integrated closer	+ € 650
	Incontro elettrico per serratura con scrocco magnetico / Electric strike for lock with magnetic latch	+ € 390
	Paraspifferi / Drafts preventer	+ € 115

### 6 ACCESSORI STIPITE / JAMBS ACCESSORIES

Stipite Jamb	Accessorio stipite Jamb accessory	Pagina listino Page price book
Stipite 45° Jamb 45°	Aggiustaggi / Adjustments	P. 83
	Rifili / Trims	

Aggiustaggi e rifili sono necessari quando i muri hanno un range di spessore diverso da 90mm-130mm  
Adjustments and trims are necessary when the walls have a thickness range different from 90mm-130mm

Serratura integrata con scrocco magnetico  
Integrated lock with magnetic latch

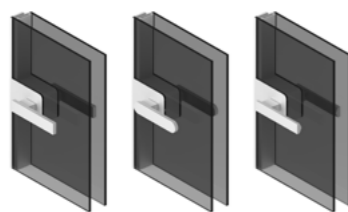

Etna Vesuvio Vulcano

#### CODICI PORTE / DOORS CODES

Tipo pannello Panel type	Stipite 45° - Stipite 45°	
	Porta singola - Single door	
	Tirare sinistra Pull left	Tirare destra Pull right
Doppio vetro - Double Glass	QS-P1-S	QS-P1-D

#### CODICI ACCESSORI PORTA / DOOR ACCESSORIES CODES

Accessori Accessories	
Chiudiporta integrato / Integrated closer	MT-84
Incontro elettrico per serratura con scrocco magnetico / Electric strike for lock with magnetic latch	MT-190
Paraspifferi / Drafts preventer	MT-86

### DIMENSIONI STANDARD / STANDARD SIZES

Porta singola Single door	Pannelli standard Standard panels	Controtelaio Counterframe
A tirare To pull or	L 633/733/833 x H 2115	L 690/790/890 ±10 x H 2150 ±10

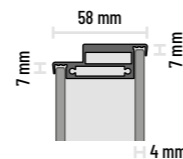

Profilo Quies  
Quies profile



Doppio vetro  
Double Glass

# Accessori per stipiti porte battenti

## Jamb accessories for hinged doors

### Stipite legno / Wooden jamb

#### AGGIUSTAGGI / ADJUSTMENTS

Aggiustaggio stipite per muri di spessore: Jamb adjustment for wall thickness:	Codici Codes
120mm - 190mm	€ 98 AN-P 100

#### RIFILI / TRIMS

Rifilo stipite per muri di spessore: Jamb trim for wall thickness:	Codici Codes
60mm - 104mm	€ 195 AN-TS

### Stipite 45° e stipite Morbida / Jamb 45° and Morbida jamb

#### AGGIUSTAGGI / ADJUSTMENTS

Aggiustaggio stipite per muri di spessore: Jamb adjustment for wall thickness:	Codici Codes
130mm - 180mm	€ 170 QD-P 250
180mm - 220mm	€ 270 QD-P 255
220mm - 260mm	€ 320 QD-P 260
260mm - 300mm	€ 370 QD-P 265

#### RIFILI / TRIMS

Rifilo stipite per muri di spessore: Jamb trim for wall thickness:	Codici Codes
60mm - 89mm	€ 98 SR-TS

### Stipite personalizzabile / Customizable jamb

#### AGGIUSTAGGI / ADJUSTMENTS

Aggiustaggio stipite per muri di spessore: Jamb adjustment for wall thickness:	Codici Codes
130mm - 180mm	€ 170 QD-P 200
180mm - 220mm	€ 270 QD-P 205
220mm - 260mm	€ 320 QD-P 210
260mm - 300mm	€ 370 QD-P 215

#### RIFILI / TRIMS

Rifilo stipite per muri di spessore: Jamb trim for wall thickness:	Codici Codes
60mm - 89mm	€ 150 SR-TS

#### COPRIFILI / FINISHING LISTS

Dimensioni controtelaio: Counterframe dimensions:		Porta singola Single door			Porta due ante Double door						
Larghezza: Width:	Altezza: High:	Alluminio Aluminium	Legno/Laccato Wood/lacquered	Vetro Glass	Cuoio rigen. Regen. leather	Cuoio Leather	Alluminio Aluminium	Legno/Laccato Wood/lacquered	Vetro Glass	Cuoio rigen. Regen. leather	Cuoio Leather
L standard	H standard	€ 185	€ 200	€ 240	€ 280	€ 350	€ 185	€ 220	€ 260	€ 300	€ 380
	H < 2400	€ 185	€ 200	€ 240	€ 280	€ 350	€ 185	€ 220	€ 260	€ 300	€ 380
L custom	H 2200 - 2600	€ 180	€ 220	€ 260	€ 300	€ 370	€ 200	€ 240	€ 280	€ 320	€ 400
	H 2600 - 3000	€ 195	€ 240	€ 280	€ 320	€ 390	€ 215	€ 260	€ 300	€ 340	€ 420

#### CODICI COPRIFILI / FINISHING LISTS CODES

Coprifilo Finishing list	Porta singola Single door	Porta due ante Double door
Anteriore / Front	TR-CA60	TR-CA62
Posteriore / Back	TR-CP60	TR-CP62

Dimensioni std controtelaio porta singola: L 690/790/890 x H 2150  
Std dimensions for single door counterframes: L 690/790/890 x H 2150

Larghezza custom per controtelaio porta singola: L > 1190  
Custom width for single door counterframes: L > 1190

Dimensioni std controtelaio porta a due ante: L 1190 x H 2150  
Std dimensions for double door counterframes: L 1190 x H 2150

Larghezza custom per controtelaio porta due ante: L 1190 - L 2190  
Custom width for double door counterframes: L 1190 - L 2190

### Stipite slim / Slim jamb

#### AGGIUSTAGGI / ADJUSTMENTS

Aggiustaggio stipite per muri di spessore: Jamb adjustment for wall thickness:	Codici Codes
155mm - 205mm	€ 170 8B-P 250
205mm - 255mm	€ 270 8B-P 255
255mm - 305mm	€ 320 8B-P 260

#### RIFILI / TRIMS

Rifilo stipite per muri di spessore: Jamb trim for wall thickness:	Codici Codes
60mm - 99mm	€ 150 8B-TS

# PORTE EFFETTO FILOMURO

## FLUSH-EFFECT DOOR

La porta "battente effetto filomuro" è una porta tradizionale il cui effetto visivo finale è simile ad una filomuro, ma con un'installazione più semplice. Un unico pannello porta che, quando è chiuso, copre la cornice realizzando un minimo rilievo rispetto alla superficie della parete. Una soluzione di facile installazione e senza lavorazioni speciali che si adatta a vani porta standard con contro telaio.

The "flush-effect door" is a traditional door that produces a final visual effect that is similar to a flush door. However, our model is much simpler to install. It is a single panel door that, when closed, covers the frame, creating a minimal protrusion in relation to the wall surface. This easy to install solution, without any special work required, is suitable for a standard door space with a counterframe.

### Sistema prodotto / Product system

**TIPOLOGIA**  
TIPOLOGY

**QUALE SOLUZIONE CERCHI?**  
WHAT SOLUTION ARE YOU LOOKING FOR?

**APPLICAZIONE**  
IMPLEMENTATION

**COME LA SOLUZIONE SI INTEGRA NEL PROGETTO?**  
HOW DOES THE SOLUTION INTEGRATE INTO THE PROJECT?

**PRODOTTO**  
PRODUCT

**QUAL È L'ESTETICA DEL PRODOTTO?**  
WHAT IS THE AESTHETICS OF THE PRODUCT?

**PORTE EFFETTO FILOMURO**  
FLUSH-EFFECT DOOR

**STIPITE EFFETTO FILOMURO**  
FLUSH-EFFECT JAMB  
P. 86

**STIPITE BILICO EFFETTO FILOMURO**  
FLUSH-EFFECT PIVOTING JAMB  
P. 90

**LEVEL**  
P. 88

**BOISÉ**  
P. 92

# Stipite effetto filomuro

## Flush-effect jamb

La soluzione "effetto filomuro" restituisce una superficie continua tra stipite e pannello porta. Stipite e pannello porta sono integrati permettendo di ottenere un'unica finitura, praticamente senza interruzioni e cerniere visibili. Questa soluzione è integrabile su qualsiasi tipologia di parete e foro architettonico, al posto di una porta tradizionale. Il risultato estetico è un "quadro" della finitura scelta, appena in aggetto sulla parete, pulito e minimale.

The "flush-effect door" solution provides a continuous surface for the wall and door panel. The door jamb and panel are built-in, making it possible to achieve a single finish, almost without interruptions and visible hinges. This solution can be used with any type of wall and architectural opening, in place of a traditional door. The aesthetic result is that of a "picture" of the chosen finish, overhanging the wall - clean and minimal.

### Porta singola / Single door

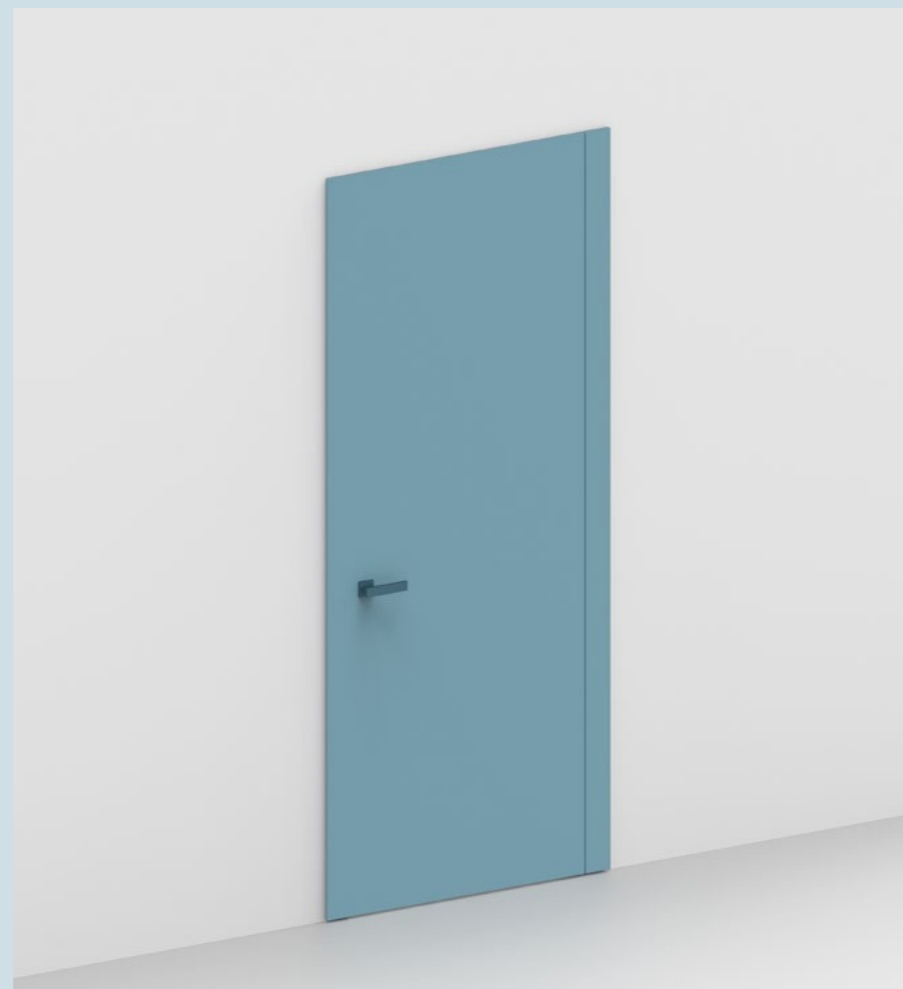

Porta singola  
Single door

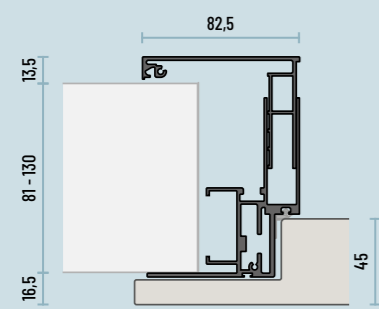
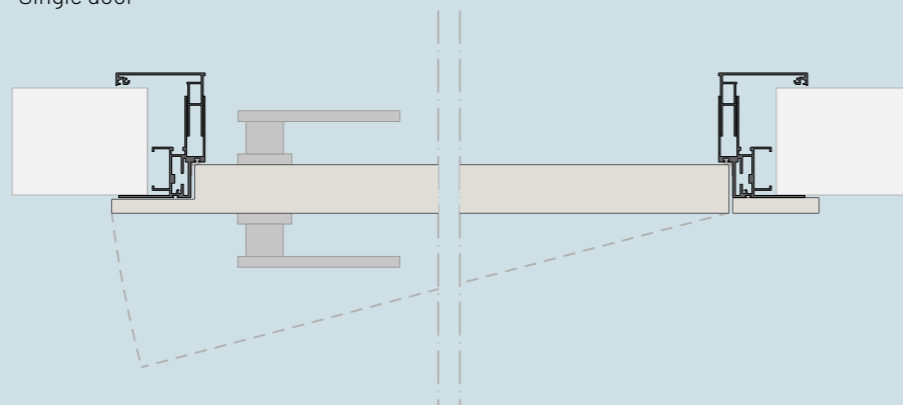

Dimensioni (mm) stipite effetto filomuro con porta Level  
Dimensions (mm) flush effect jamb with Level door

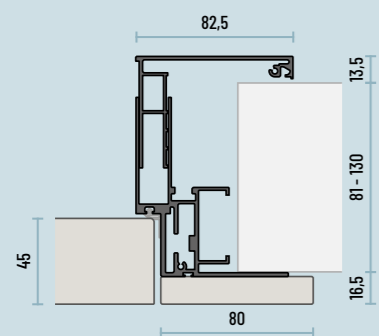

Dimensioni (mm) stipite effetto filomuro con porta Level  
Dimensions (mm) flush effect jamb with Level door

### Dettagli / Details

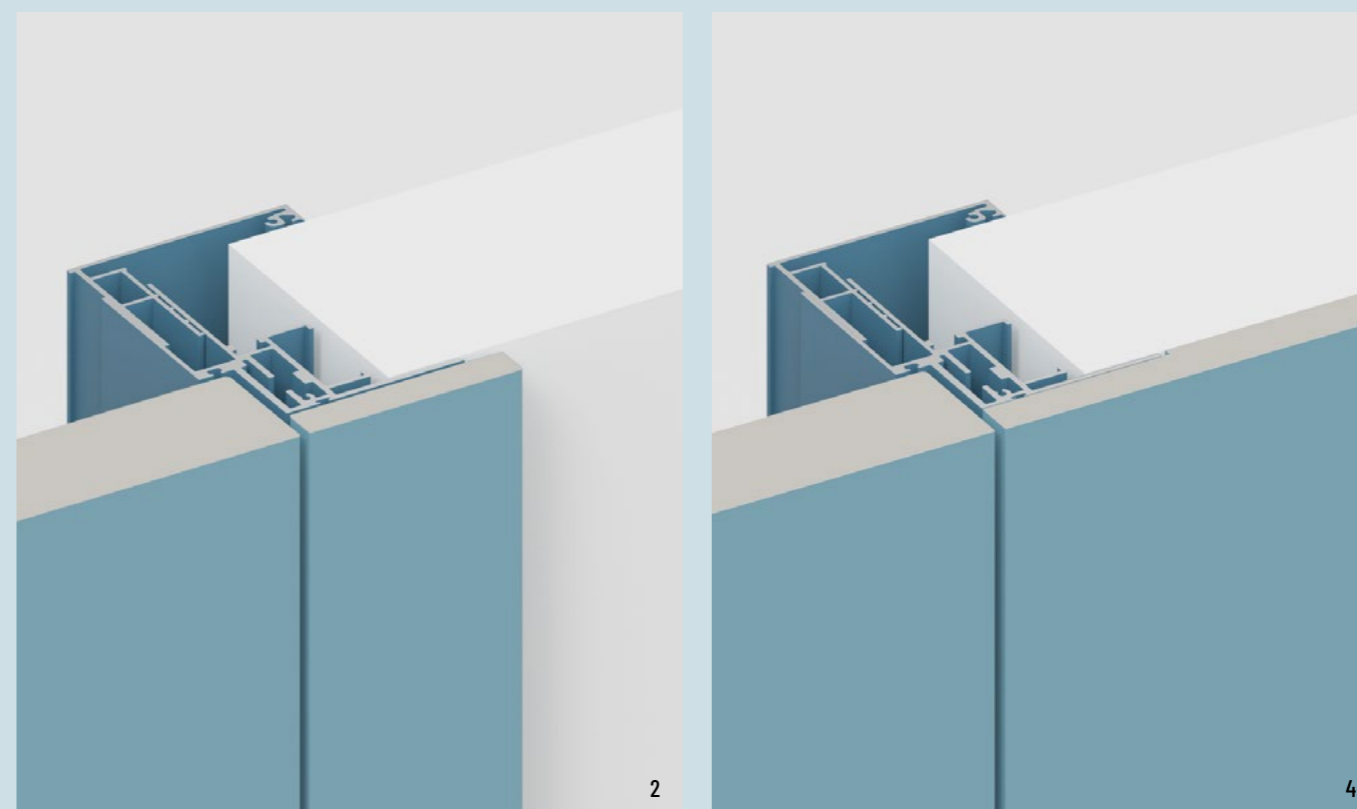
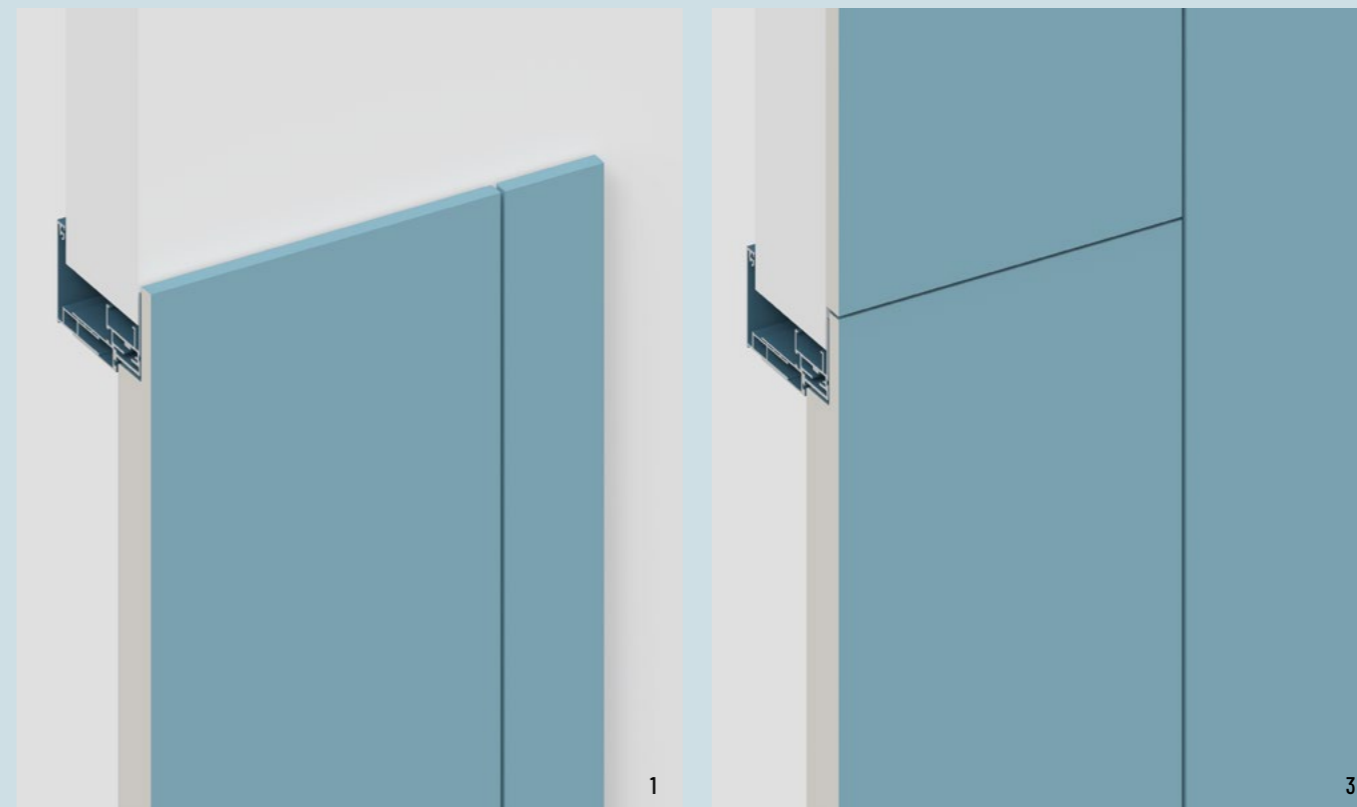

1. Sezione verticale Stipite effetto filomuro con porta Level  
1. Vertical section Flush-effect jamb with Level door

2. Sezione orizzontale Stipite effetto filomuro con porta Level  
2. Horizontal section Flush-effect jamb with Level door

3. Sezione verticale Stipite effetto filomuro con porta Level e boiserie a incollaggio  
3. Vertical section Flush-effect jamb with Level door and boiserie gluing

4. Sezione orizzontale Stipite effetto filomuro con porta Level e boiserie a incollaggio  
4. Horizontal section Flush-effect jamb with Level door and boiserie gluing

# Level

## 1 PORTE SINGOLE STANDARD / STANDARD SINGLE DOORS

Tipo pannello Panel type	Finitura pannello Panel finishing	Finitura stipite Jamb finishing	Finitura telaio pannello Frame panel finishing	Stipite effetto filomuro Flush-effect jamb
Pannello legno Wooden panel	[1] Laccato standard Standard lacquered	Bianco RAL 9003 White RAL 9003	-	€ 1.390
Doppio vetro Double glass	[2] Vetro opaco cat. C Opaque glass cat. C	Bianco RAL 9003 White RAL 9003	Bianco RAL 9003 White RAL 9003	€ 1.950

## 2 DIMENSIONI CUSTOM / CUSTOM SIZES

Tipo pannello Panel type	Per controtelai: For counterframes:	L < 1090 ±10
Pannello legno Wooden panel	H < 2200 ±10	+ € 150
	H < 2700 ±10	+ € 450
Doppio vetro Double glass	H < 2200 ±10	+ € 150
	H < 2700 ±10	+ € 450

Per qualsiasi larghezza custom per controtelaio fino a L 1090 ±10  
For any custom width for counterframe up to L 1090 ±10

## 3 FINITURE / FINISHINGS

Tipo elemento Element type	Finitura Finishing	P. 30
Pannello legno Wooden panel	Laccato custom RAL Custom RAL lacquered	+ € 200
	Essenza legno Wood essence	+ € 270
Doppio vetro Double glass	Vetro opaco cat. D Opaque glass cat. D	+ 5%
Stipite Jamb	Custom RAL Custom RAL	+ € 390
Telaio pannello Frame panel	Custom RAL Custom RAL	+ € 190

## 4 SISTEMI DI CHIUSURA / CLOSING SYSTEMS

Tipo pannello Panel type	Sistema di chiusura Closing system	Senza blocco Whitout block	Chiave Patent Patent key	Nottolino Latch free/busy	Chiave Yale Yale key
Tutti i pannelli All panels	Serr. scrocco magn. per maniglia standard Lock with magnetic latch for standard handles	+ € 90 *	+ € 45	+ € 45	+ € 50 **

## 5 MANIGLIE / HANDLES

Tipo pannello Panel type	Sistema di chiusura Closing system	Maniglia Handle	Senza blocco Whitout block	Chiave Patent Patent key	Nottolino Latch free/busy	Chiave Yale Yale key
Tutti i pannelli All panels	Serr. scrocco magnetico per maniglia standard Lock with magnetic latch for standard handles	Etna	+ € 190	+ € 190	+ € 210	+ € 190
		Vesuvio*	+ € 230	+ € 230	+ € 250	+ € 230
		Vulcano	+ € 190	+ € 190	+ € 210	+ € 190
		Fuji	+ € 80	+ € 80	+ € 110	+ € 80
		Teide	+ € 80	+ € 80	+ € 110	+ € 80

\* Al momento dell'ordine specificare la scelta tra rosetta e bocchetta quadrate o tonde  
\* When ordering, specify the choice between square or round rosette and escutcheon

\*\* Al momento dell'ordine specificare la scelta tra rosetta e bocchetta quadrate o tonde  
\*\* When ordering, specify the choice between square or round rosette and escutcheon

## 6 ACCESSORI STIPITE / JAMB ACCESSORIES

Accessorio Accessory	Per muri di spessore: For wall thickness:	
Aggiustaggio Adjustment	130mm - 170mm	+ € 170
	170mm - 200mm	+ € 270
	210mm - 250mm	+ € 320
	250mm - 290mm	+ € 370
Rifilo Trim	55mm - 80mm	+ € 150

Aggiustaggi e rifili sono necessari quando i muri hanno un range di spessore diverso da 81mm-130mm  
Adjustments and trims are necessary when the walls have a thickness range different from 81mm-130mm

Aggiustaggi e rifili sono necessari quando i muri hanno un range di spessore diverso da 81mm-130mm  
Adjustments and trims are necessary when the walls have a thickness range different from 81mm-130mm

## 7 BOISERIE / BOISERIE

Tipologia Typology	Sistema System	Pagina listino Page price book
Boiserie Boiserie	Pannelli incollaggio Gluing panels	P. 286

## DIMENSIONI STANDARD / STANDARD SIZES

Porta singola Single door	Pannelli standard Standard panels	Controtelaio Counterframe
A tirare To pull	L 680/780/880 x H 2176,5	L 690/790/890 x H 2150 ±10

Al momento dell'ordine specificare il senso di apertura: sinistra o destra.  
When ordering, specify the opening side of the door: left or right.

When ordering, specify the opening side of the door: left or right.

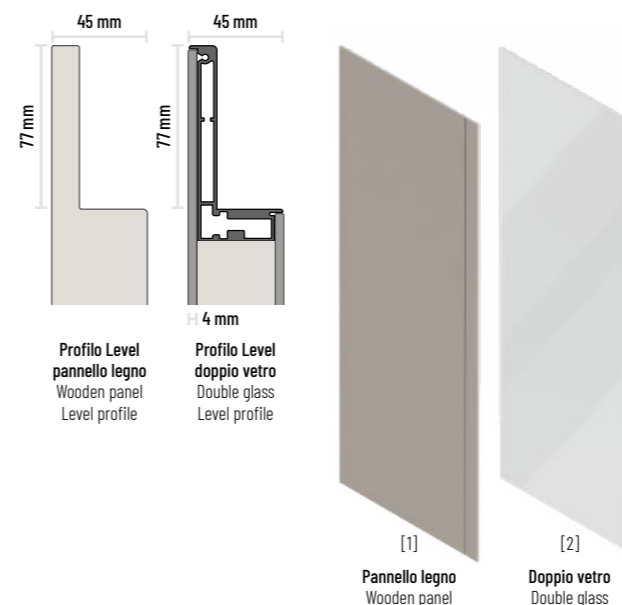

## CODICI PORTE / DOORS CODES

Tipo pannello Panel type	Stipite effetto filomuro / Flush-effect jamb	
	Sinistra / Left	Destra / Right
[1]	LV-100SX	LV-100DX
[2]	LV-200SX	LV-200DX

\* il prezzo comprende serratura e opzione "solo foro maniglia"  
\* price includes lock and "handle hole only" option

\*\* il prezzo non comprende il cilindro Yale  
\*\* price does not include Yale cylinder

\*\* il prezzo non comprende il cilindro Yale  
\*\* price does not include Yale cylinder

\*\* il prezzo non comprende il cilindro Yale  
\*\* price does not include Yale cylinder

Serratura scrocco magnetico per maniglia standard  
Lock with magnetic latch for standard handles

Lock with magnetic latch for standard handles



## CODICI SISTEMI DI CHIUSURA / CLOSING SYSTEMS CODES

Sistema di chiusura Closing system	Senza blocco Whitout block	Chiave Patent Patent key	Nottolino Lacht free/busy	Chiave Yale Yale key
Serr. scrocco magnetico per maniglia standard Lock with magnetic latch for standard handles	LVPS1	LVPS1	LVPS2	LVPS3

Configurazioni serratura scrocco magnetico per maniglia standard Lock with magnetic latch for standard handles configurations	Senza blocco Whitout block	Chiave Patent Patent key	Nottolino Lacht free/busy	Chiave Yale Yale key

## CODICI MANIGLIE / HANDLES CODES

Maniglia Handle	Senza blocco Whitout block	Chiave Patent Patent key	Nottolino Lacht free/busy	Chiave Yale Yale key
Etna	AC-350C	AC-350C	AC-350N	AC-350Y
Vesuvio*	AC-550C	AC-550C	AC-550N	AC-550Y
Vesuvio**	AC-555C	AC-555C	AC-555N	AC-555Y
Vulcano	AC-450C	AC-450C	AC-450N	AC-450Y
Fuji***	AC-120C	AC-120C	AC-120N	AC-120Y
Teide***	AC-220C	AC-220C	AC-220N	AC-220Y

\* Versione con rosetta e bocchetta quadrate / Square rosette and escutcheon version

\*\* Versione con rosetta e bocchetta tonde / Circular rosette and escutcheon version

\*\*\* Disponibile solo in finitura acciaio / Available only in steel finish

## ACCESSORI STIPITE / JAMB ACCESSORIES

Accessorio Accessory	Per muri di spessore: For wall thickness:	
Aggiustaggio Adjustment	130mm - 170mm	LV-300
	170mm - 200mm	LV-305
	210mm - 250mm	LV-310
	250mm - 290mm	LV-315
Rifilo Trim	55mm - 80mm	LV-TS

# Stipite bilico effetto filomuro

## Flush-effect pivoting jamb

La soluzione "effetto filomuro bilico" permette di chiudere vani porta o varchi tradizionali con un pannello in finitura di grandi dimensioni sul quale è posizionata una porta a bilico. In questo modo è possibile, senza alcuna preparazione edilizia, realizzare una boiserie con porta integrata, sulla quale è possibile giocare con una vasta gamma di finiture.

The "pivoting flush-effect door" solution makes it possible to close door openings or traditional openings with a large size finishing panel, in which a pivot door is positioned. In this way a boiserie can be created, with a built-in door and without any building preparation, on which an almost unlimited range of finishes can be applied.

### Porta singola / Single door

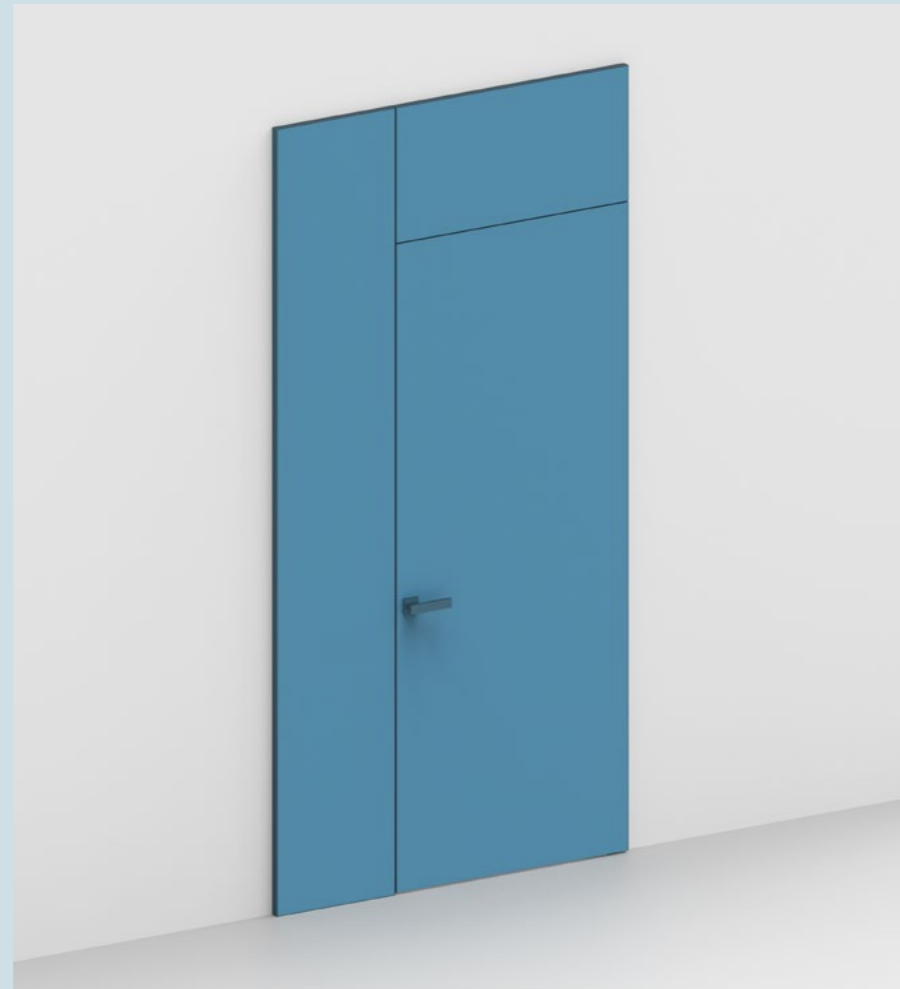

Porta singola  
Single door

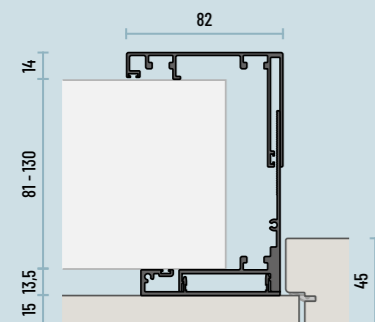
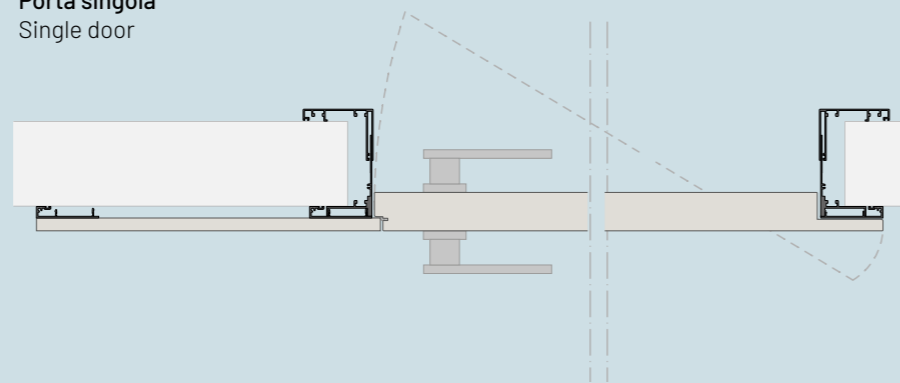

Dimensioni (mm) stipite bilico effetto filomuro con porta Boisè  
Dimensions (mm) pivoting flush-effect jamb with Boisè door

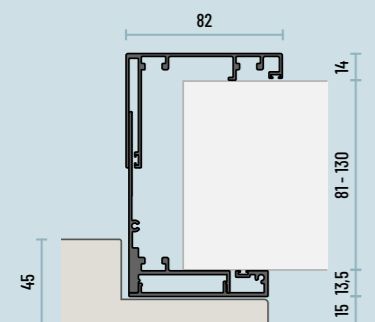

Dimensioni (mm) stipite bilico effetto filomuro con porta Boisè  
Dimensions (mm) pivoting flush-effect jamb with Boisè door

### Dettagli / Details

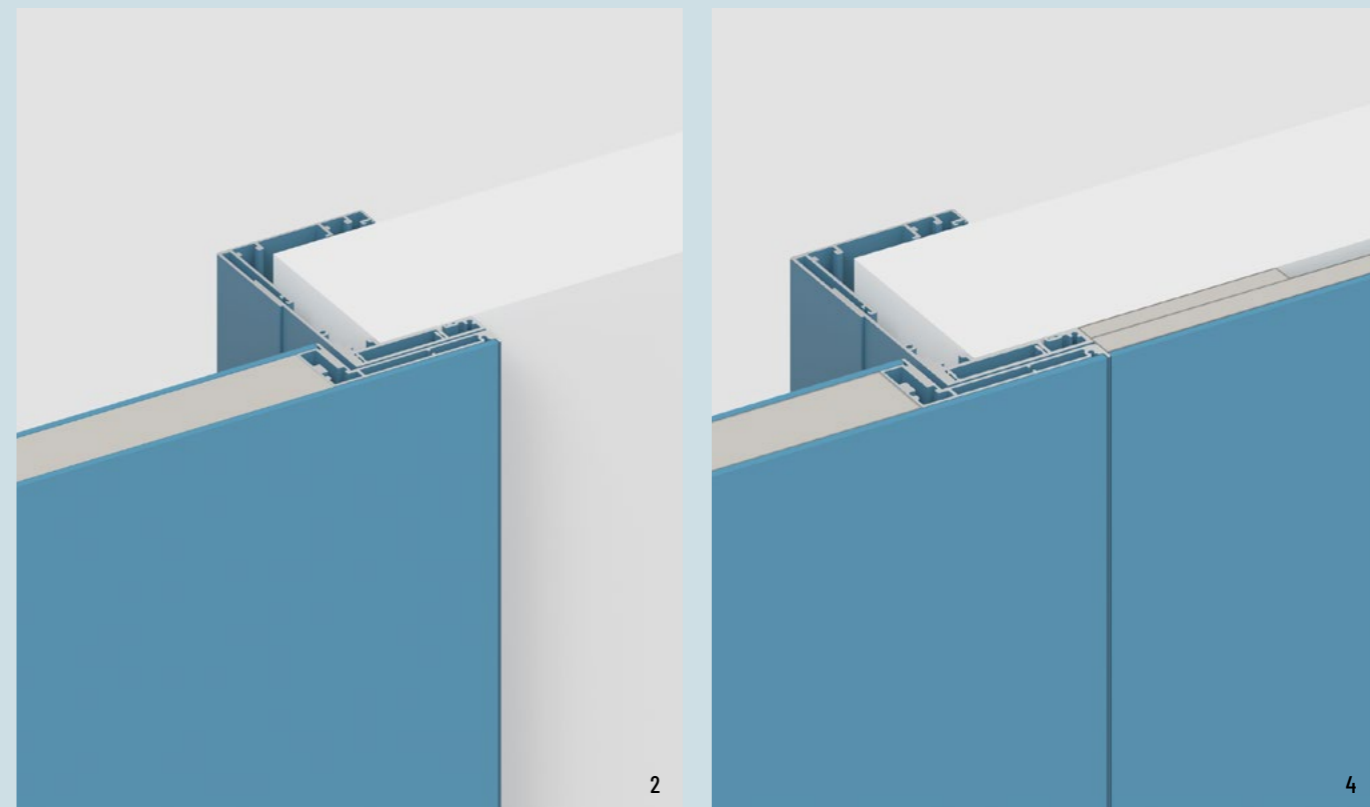
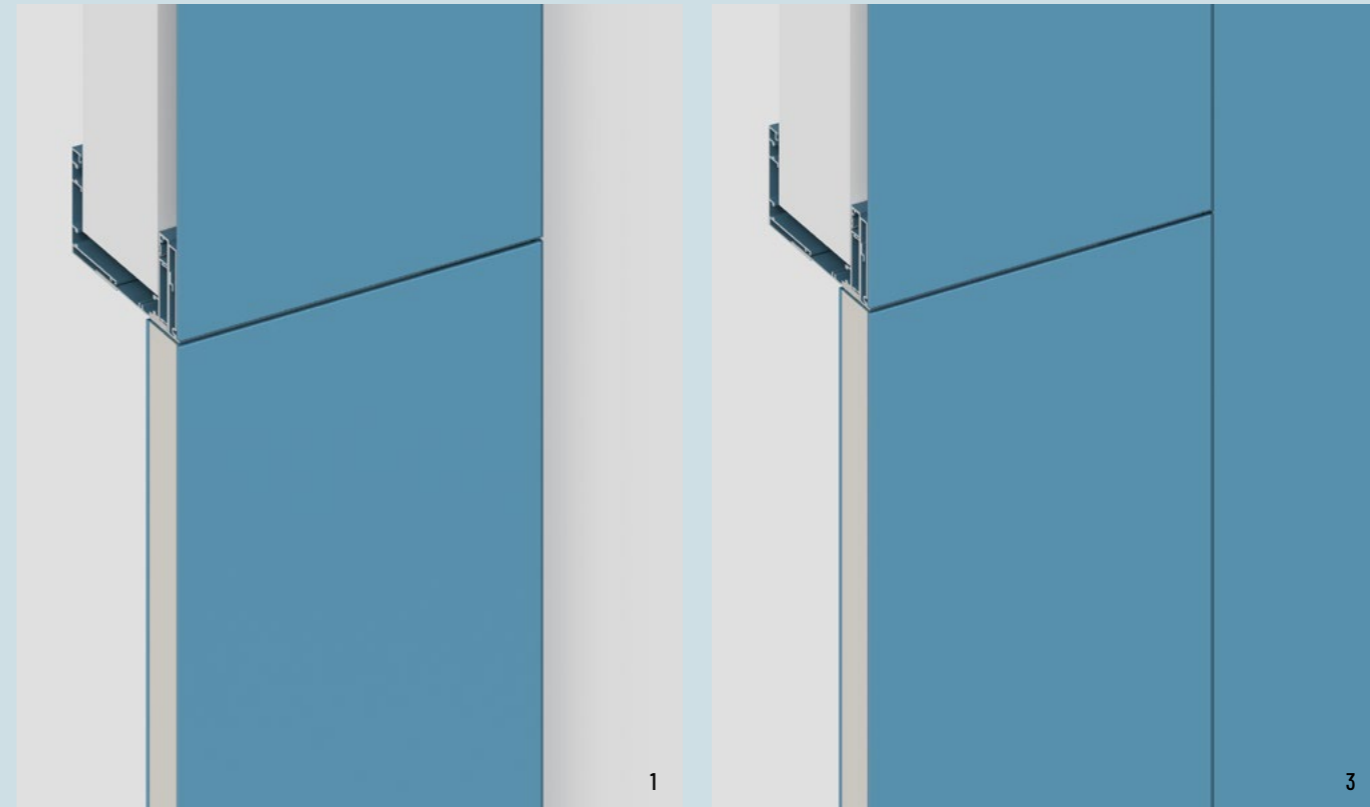

1. Sezione verticale Stipite effetto filomuro bilico con porta Boisè  
1. Vertical section Pivoting flush-effect jamb with Boisè door

2. Sezione orizzontale Stipite effetto filomuro bilico con porta Boisè  
2. Horizontal section Pivoting flush-effect jamb with Boisè door

3. Sezione verticale Stipite effetto filomuro bilico con porta Boisè e boiserie a montaggio  
3. Vertical section Pivoting flush-effect jamb with Boisè door and boiserie mounting

4. Sezione orizzontale Stipite effetto filomuro con porta Boisè e boiserie a montaggio  
4. Horizontal section Flush-effect jamb with Boisè door and boiserie mounting

# Boisé

## 1 PORTE SINGOLE STANDARD / STANDARD SINGLE DOORS

Tipo pannello Panel type	Finitura pannello Panel finishing	Finitura stipite Jamb finishing	Finitura telaio pannello Frame panel finishing	Stipite bilico effetto filomuro Pivoting flush-effect jamb
<b>Pannello legno</b> Wooden panel	[1] <b>Laccato standard</b> Standard lacquered	<b>Finitura alluminio anodizzato</b> Anodized aluminum finishing	-	€ 2.150
<b>Doppio vetro</b> Double glass	[2] <b>Vetro opaco cat. C</b> Opaque glass cat. C	<b>Finitura alluminio anodizzato</b> Anodized aluminum finishing	<b>Finitura alluminio anodizzato</b> Anodized aluminum finishing	€ 3.250

## 2 VARIAZIONE ALTEZZA / HEIGHT VARIATION

Tipo pannello Panel type	Altezza tot con pannellatura Total height with panels	
<b>Pannello legno</b> Wooden panel	H 2600	+ € 100
	H 2900*	+ € 200
<b>Doppio vetro</b> Double glasse	H 2600	+ € 100
	H 2900	+ € 200

\*necessario aggiungere un accessorio "coppia di tiranti radrizzanti" P. 135  
\*it is necessary to add a "pair of straightening rods" accessory P.135

## 3 VARIAZIONE LARGHEZZA / WIDTH VARIATION

Tipo pannello Panel type	Larghezza tot con pannellatura Total idth with panels	
<b>Pannello legno</b> Wooden panel	L 1500	+ € 200
<b>Doppio vetro</b> Double glass	L 1500	+ € 200

## DIMENSIONI STANDARD / STANDARD SIZES

Porta singola Single door	Ingombro tot Total size	Pannello porta Door panel	Controtelaio Counterframe
<b>Porta bilico</b> Pivoting door	L 1300 x H 2400	L 904 x H 2112	L 890 x H 2150 ±10

## 4 FINITURE / FINISHINGS

Tipo pannello Panel type	Finitura Finishing	P. 30
<b>Pannello legno</b> Wooden panel	<b>Laccato custom RAL</b> Custom RAL lacquered	+ € 200
	<b>Essenza legno</b> Wood essence	+ € 550
<b>Doppio vetro</b> Double glass	<b>Vetro opaco cat. D</b> Opaque glass cat. D	+ 5%

## 5 SISTEMI DI CHIUSURA / CLOSING SYSTEMS

Tipo pannello Panel type	Sistema di chiusura Closing system	Senza blocco Whitout block	Chiave Patent Patent key	Nottolino Latch free/busy	Chiave Yale Yale key
<b>Tutti i pannelli</b> All panels	<b>Serr. scrocco magn. per maniglia standard</b> Lock with magnetic latch for standard handles	+ € 90 *	+ € 45	+ € 45	+ € 50 **

\* il prezzo comprende serratura e opzione "solo foro maniglia"  
\* price includes lock and "handle hole only" option

\*\* il prezzo non comprende il cilindro Yale  
\*\* price does not include Yale cilinder

## 6 MANIGLIE / HANDLES

Tipo pannello Panel type	Sistema di chiusura Closing system	Maniglia Handle	Chiave Patent Patent key	Nottolino Latch free/busy	Chiave Yale Yale key
<b>Tutti i pannelli</b> All panels	<b>Serr. scrocco magnetico per maniglia standard</b> Lock with magnetic latch for standard handles	<b>Etna</b>	+ € 190	+ € 190	+ € 210
		<b>Vesuvio*</b>	+ € 230	+ € 230	+ € 250
		<b>Vulcano</b>	+ € 190	+ € 190	+ € 210
		<b>Fuji</b>	+ € 80	+ € 80	+ € 110
		<b>Teide</b>	+ € 80	+ € 80	+ € 110

\* Al momento dell'ordine specificare la scelta tra rosetta e bocchetta quadrate o tonde  
\* When ordering, specify the choice between square or round rosette and escutcheon

## 7 BOISERIE / BOISERIE

Tipologia Typology	Sistema System	Pagina listino Page price book
<b>Boiserie</b> Boiserie	<b>Pannelli montaggio</b> Mounting panels	P. 288

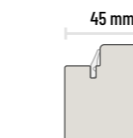

Profilo Boisè pannello legno  
Wooden panel Boisè profile

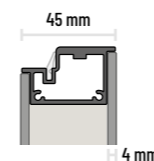

Profilo Boisè doppio vetro  
Double glass Boisè profile

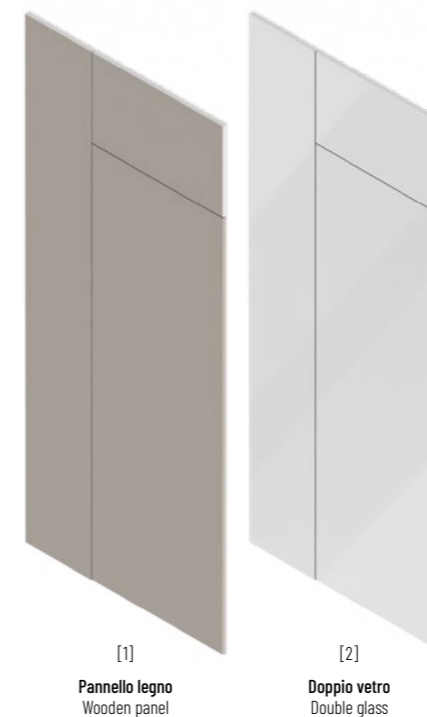

[1]  
**Pannello legno**  
Wooden panel

[2]  
**Doppio vetro**  
Double glass

## CODICI PORTE / DOORS CODES

Tipo pannello Panel type	Stipite effetto filomuro bilico Pivoting flush-effect jamb
[1]	BS-P10
[2]	BS-P11

Serratura scrocco magnetico per maniglia standard  
Lock with magnetic latch for standard handles

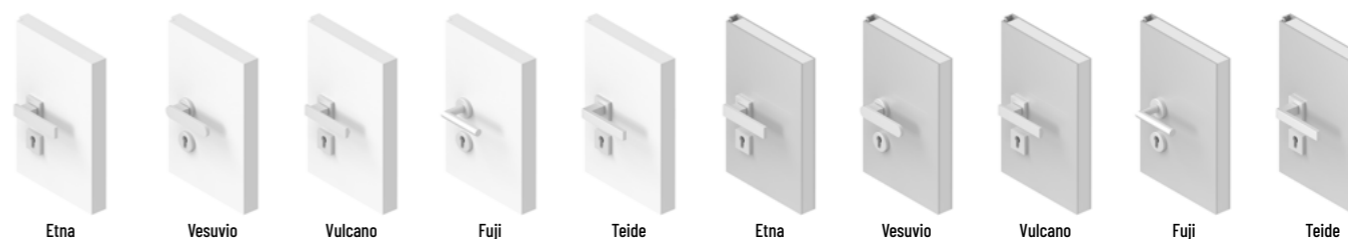

## CODICI SISTEMI DI CHIUSURA / CLOSING SYSTEMS CODES

Sistema di chiusura Closing system	Senza blocco Whitout block	Chiave Patent Patent key	Nottolino Lacht free/busy	Chiave Yale Yale key
<b>Serr. scrocco magnetico per maniglia standard</b> Lock with magnetic latch for standard handles	LVPS1	LVPS1	LVPS2	LVPS3

Configurazioni serratura scrocco magnetico per maniglia standard Lock with magnetic latch for standard handles configurations	Senza blocco Whitout block	Chiave Patent Patent key	Nottolino Latch free/busy	Chiave Yale Yale key

## CODICI MANIGLIE / HANDLES CODES

Maniglia Handle	Senza blocco Whitout block	Chiave Patent Patent key	Nottolino Lacht free/busy	Chiave Yale Yale key
<b>Etna</b>	AC-350C	AC-350C	AC-350N	AC-350Y
<b>Vesuvio*</b>	AC-550C	AC-550C	AC-550N	AC-550Y
<b>Vesuvio**</b>	AC-555C	AC-555C	AC-555N	AC-555Y
<b>Vulcano</b>	AC-450C	AC-450C	AC-450N	AC-450Y
<b>Fuji***</b>	AC-120C	AC-120C	AC-120N	AC-120Y
<b>Teide***</b>	AC-220C	AC-220C	AC-220N	AC-220Y

\* Versione con rosetta e bocchetta quadrate / Square rosette and escutcheon version

\*\* Versione con rosetta e bocchetta tonde / Circular rosette and escutcheon version

\*\*\* Disponibile solo in finitura acciaio / Available only in steel finish

Tavoli  
Table  
 Librerie  
Bookcase  
 Cabine armadio  
Walk-in closet  
 Boiserie  
Boiserie  
 Pareti divisorie  
Partition wall  
 Pan. scorrevoli o girevoli  
Sliding or pivoting panels  
 Porte a scomparsa  
Pocket door  
 Porte senza falso telaio  
Door w/o basic door frame  
 Porte filomuro  
Flush door  
 Porte battenti con cornice  
Hinged door and frame  
 Informazioni generali  
General informations

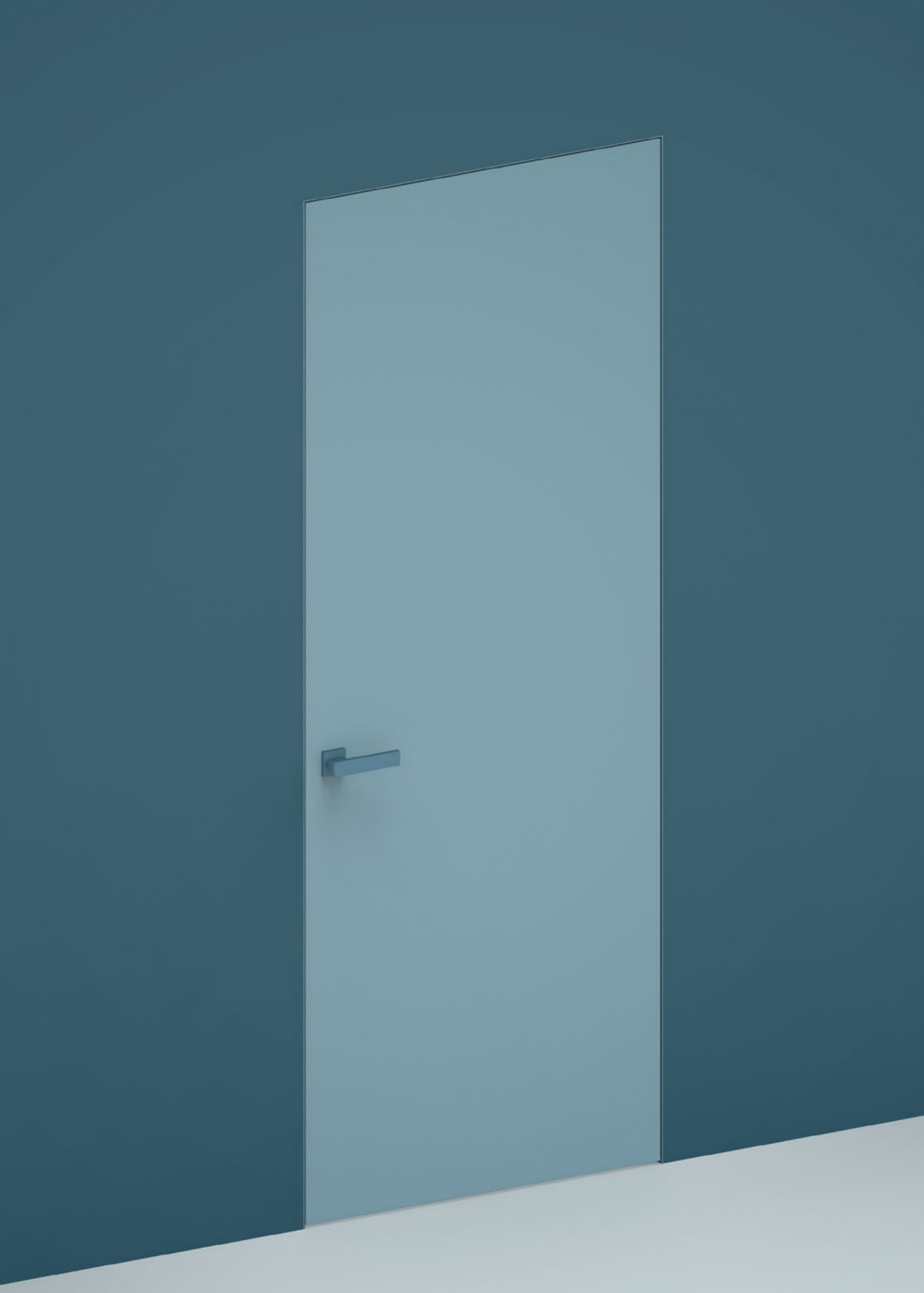

# PORTE FILOMURO

## FLUSH DOOR

La porta "filomuro" è soluzione ideale per chi cerca una pulizia essenziale. Lo stipite della porta viene integrato nel muro lasciando visibile solo il pannello. Meccanica ed estetica si combinano per produrre una porta in grado di adattarsi alle esigenze più stringenti di progettazione e rispondere ai requisiti tecnici di cantiere. Disponibile per applicazioni su cartongesso o su muratura.

The "flush" door is ideal for anyone looking for clean lines. The door jamb is built into the wall, leaving only the panel visible. Mechanics and aesthetics combine to make a door that is able to satisfy the most stringent design needs, while meeting the technical requirements of the worksite. Available for installation with drywall or brick walls

### Sistema prodotto / Product system

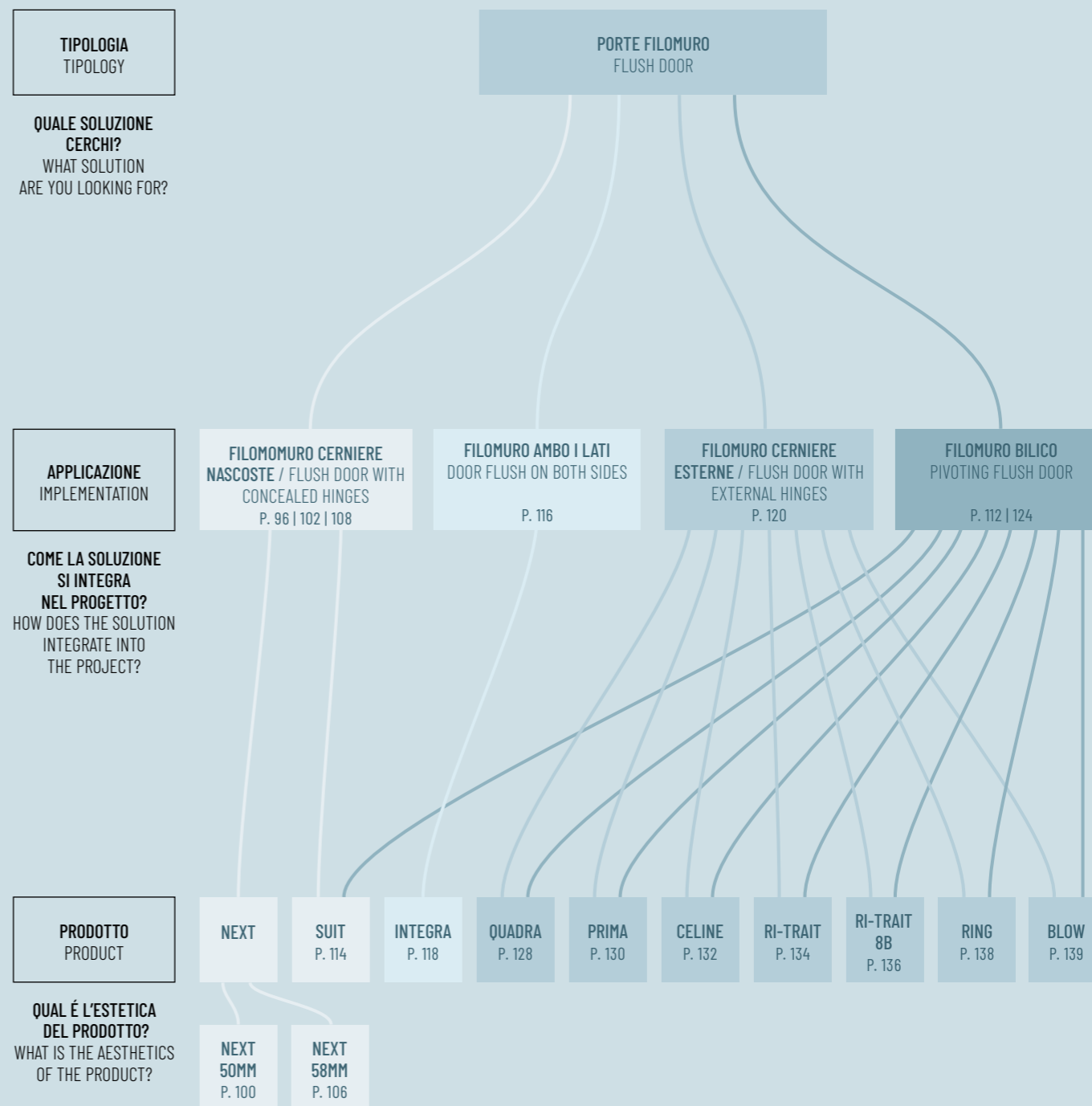

Tavoli  
Table  
 Librerie  
Bookcase  
 Cabine armadio  
Walk-in closet  
 Boiserie  
Boiserie  
 Pareti divisorie  
Partition wall  
 Pan. scorrevoli o girevoli  
Sliding or pivoting panels  
 Porte a scomparsa  
Pocket door  
 Porte senza falso telaio  
Door w/o basic door frame  
 Porte filomuro  
Flush door  
 Porte battenti con cornice  
Hinged door and frame  
 Informazioni generali  
General informations



# Filomuro cerniere nascoste (50mm | Next)

## Flush door with concealed hinges (50mm | Next)

Lo stipite "filomuro con cerniere nascoste" per pannelli da 50mm | Next permette di realizzare la classica porta a filomuro, pressochè invisibile sulla parete. Le cerniere a scomparsa sono incassate all'interno dello stipite e del pannello porta permettendo una completa complanarietà tra porta e parete senza alcuna presenza visibile. L'effetto che si ottiene è di estrema pulizia. Albed utilizza cerniere certificate, regolabili sui 3 assi.

The "flush door with concealed hinges" jamb for 50mm | Next thickness panels can be used to form a classical flush door, which is almost invisible on the wall. The concealed hinges are recessed in the jamb and the door panel, allowing the door and wall to be completely flush, without any visible presence. Albed uses certified hinges that can be adjusted on three axes.

### Porta singola / Single door

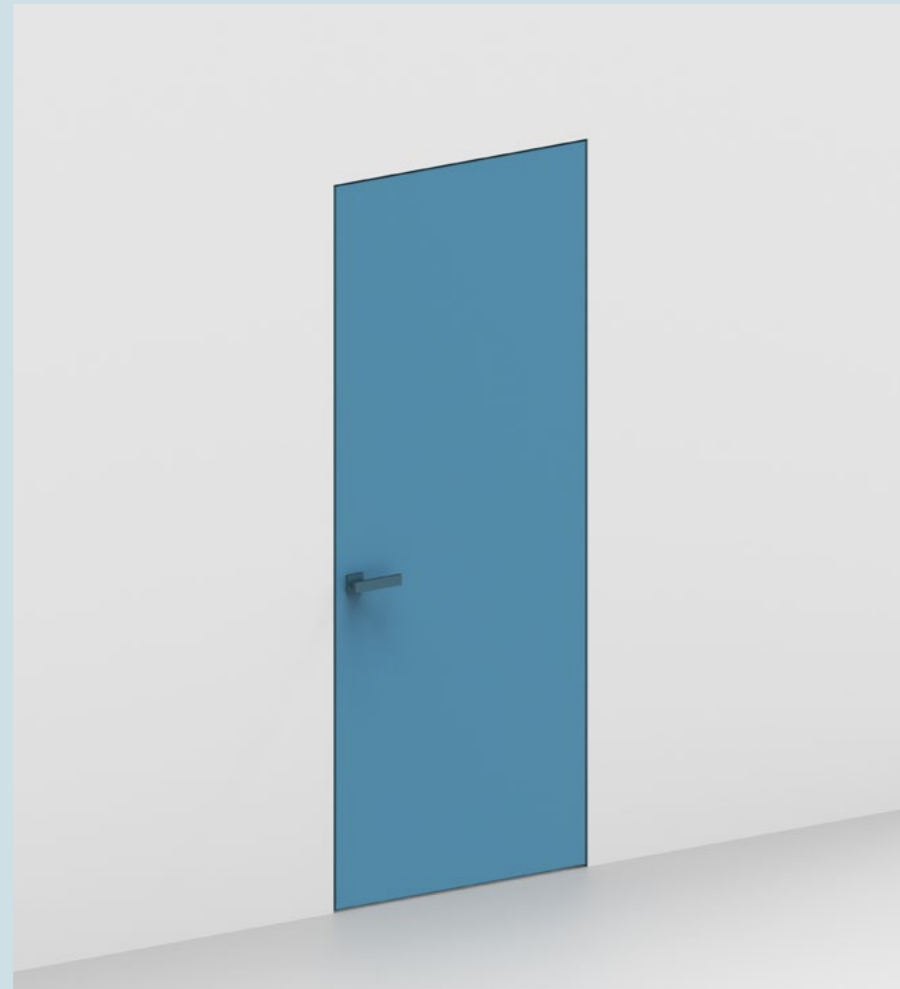

**Porta singola a tirare**  
Single pull door

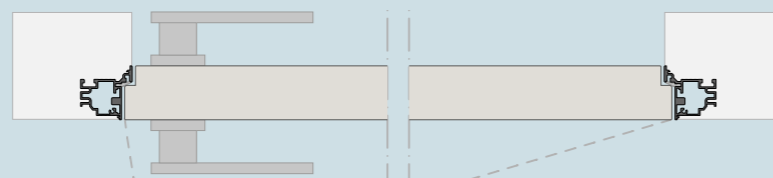

**Porta singola a spingere**  
Single push door

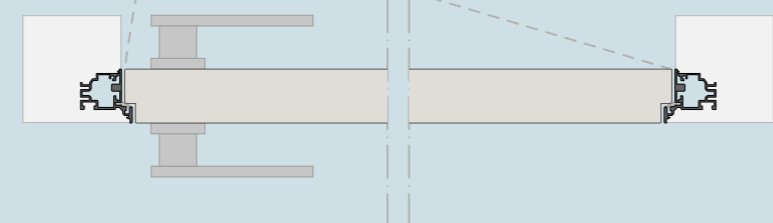

### Porta a due ante / Double door



**Porta a due ante asimmetriche a tirare**  
Asymmetrical double pull door

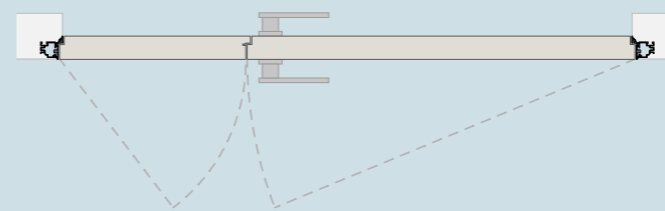

**Porta a due ante asimmetriche a spingere**  
Asymmetrical double push door

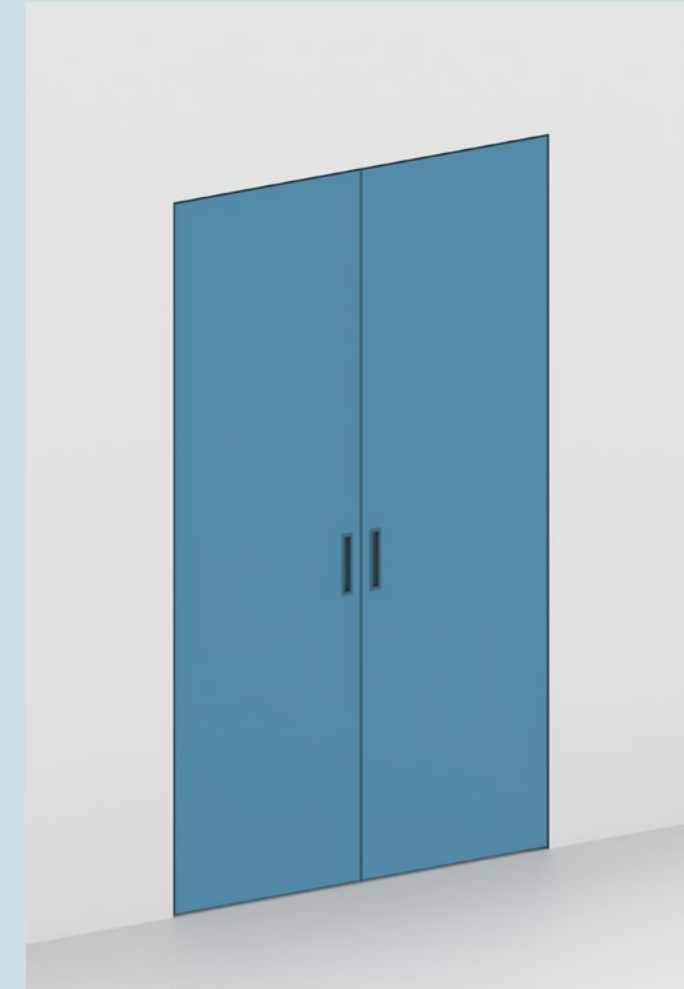
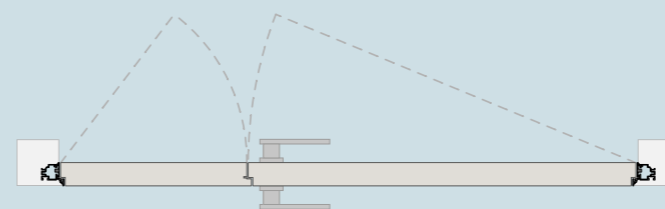

**Porta a due ante simmetriche a tirare**  
Symmetrical double pull door

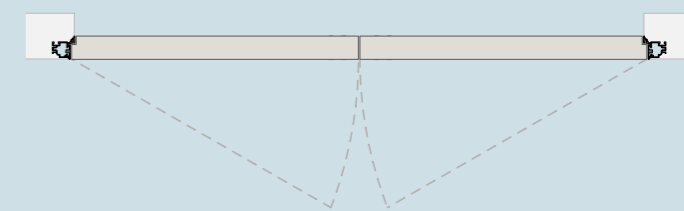

**Porta a due ante simmetriche a spingere**  
Symmetrical double push door

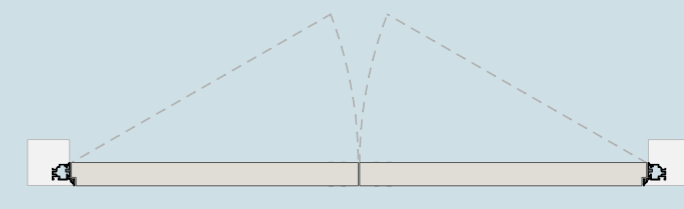

# Filomuro cerniere nascoste (50mm | Next)

## Flush door with concealed hinges (50mm | Next)

### Compatibilità / Compatibilities

### Dettagli / Details

#### Next 50mm

P. 100



Next 50mm pannello legno a tirare  
Wooden panel Next 50mm to pull



Next 50mm pannello legno a spingere  
Wooden panel Next 50mm to push



Next 50mm doppio vetro a tirare  
Double door Next 50mm to pull



Next 50mm doppio vetro a spingere  
Double door Next 50mm to push

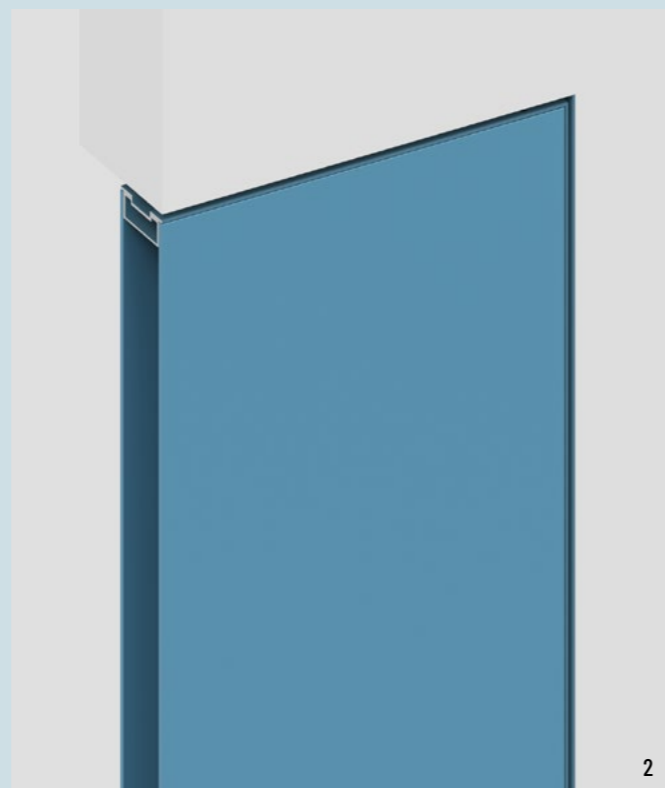
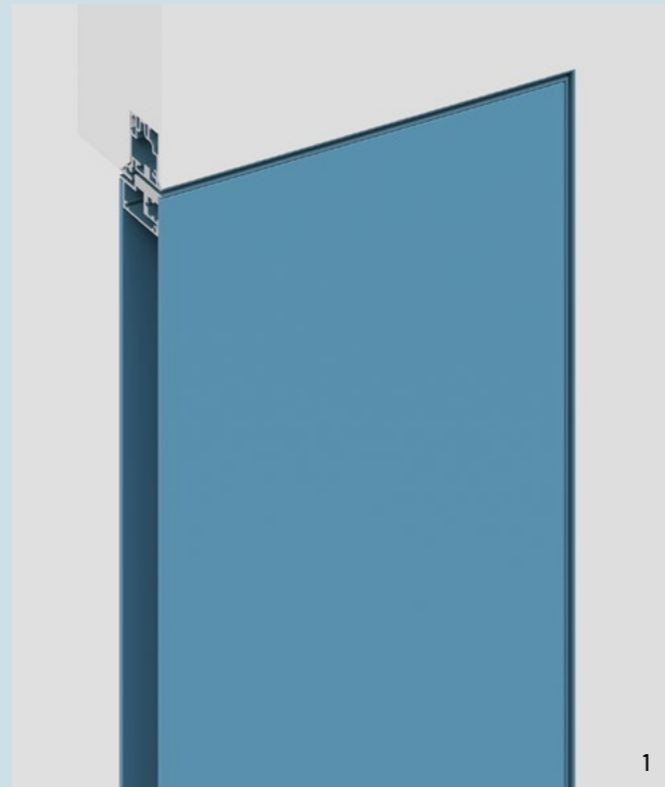

**1. Sezione verticale filomuro cerniere nascoste (stipite su tre lati) con Next doppio vetro a tirare**  
1. Vertical section flush door with concealed hinges (jamb on three sides) with Next double glass to pull

**2. Sezione verticale filomuro cerniere nascoste (tutta altezza) con Next doppio vetro a tirare o a spingere**  
2. Vertical section flush door with concealed hinges (all height) with Next double glass to pull or to push

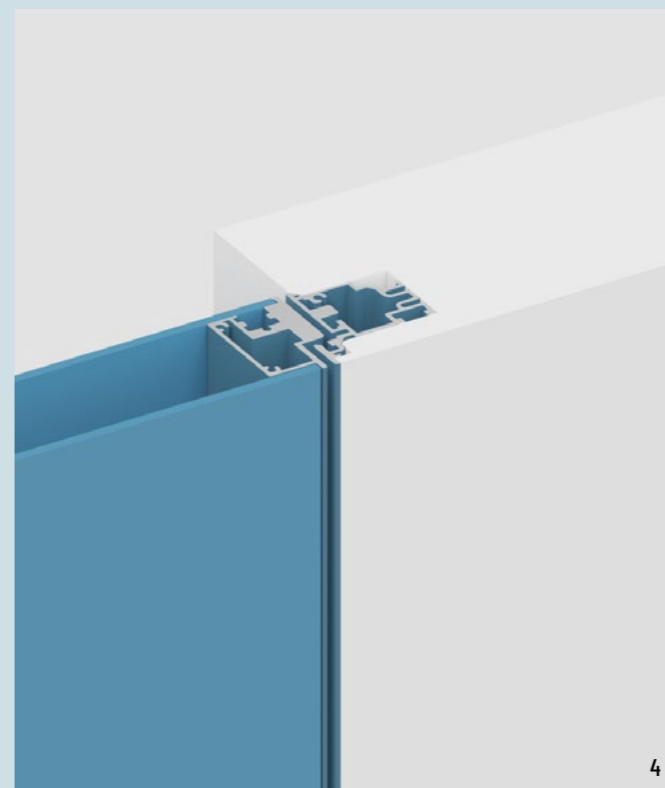
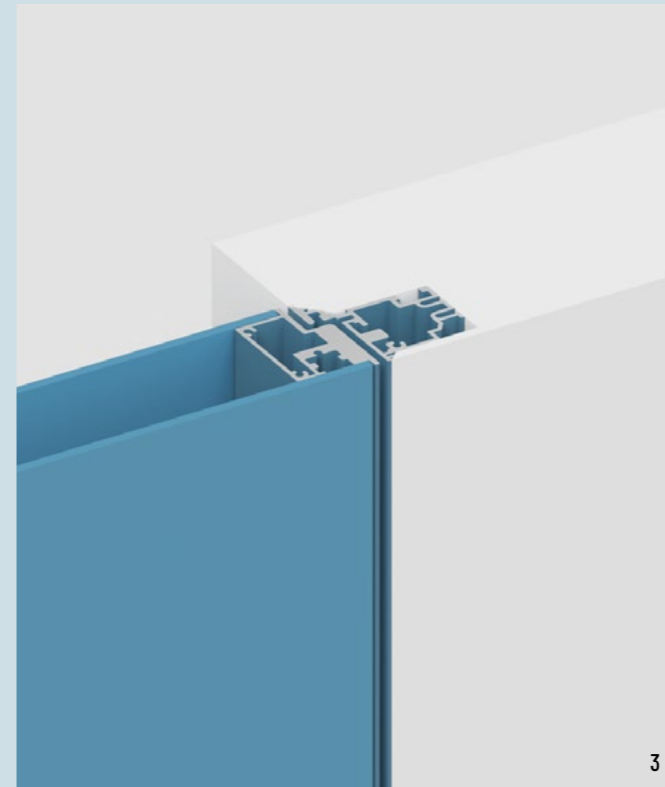

**3. Sezione orizzontale filomuro cerniere nascoste con Next doppio vetro a tirare**  
3. Horizontal section flush door with concealed hinges with Next double glass to pull

**4. Sezione orizzontale filomuro cerniere nascoste con Next doppio vetro a spingere**  
4. Horizontal section flush door with concealed hinges with Next double glass to push

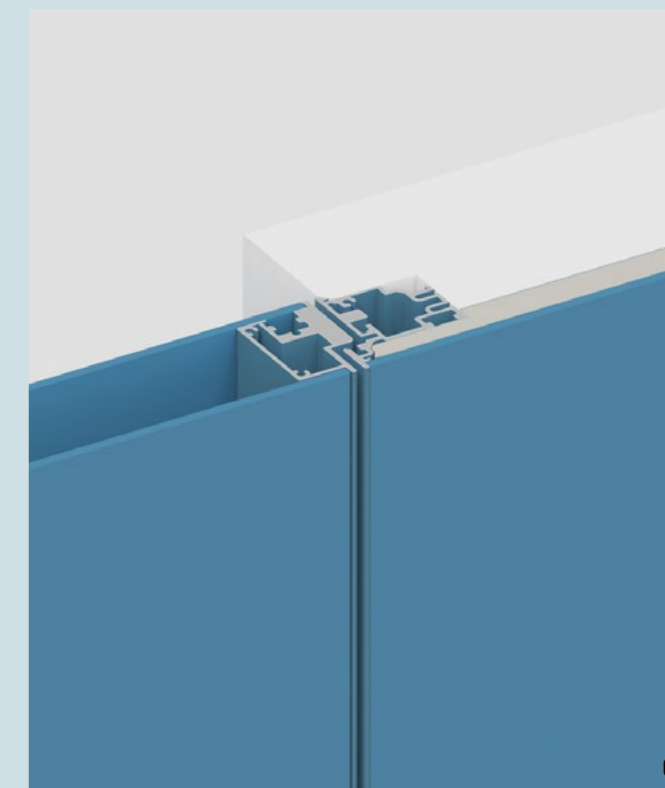
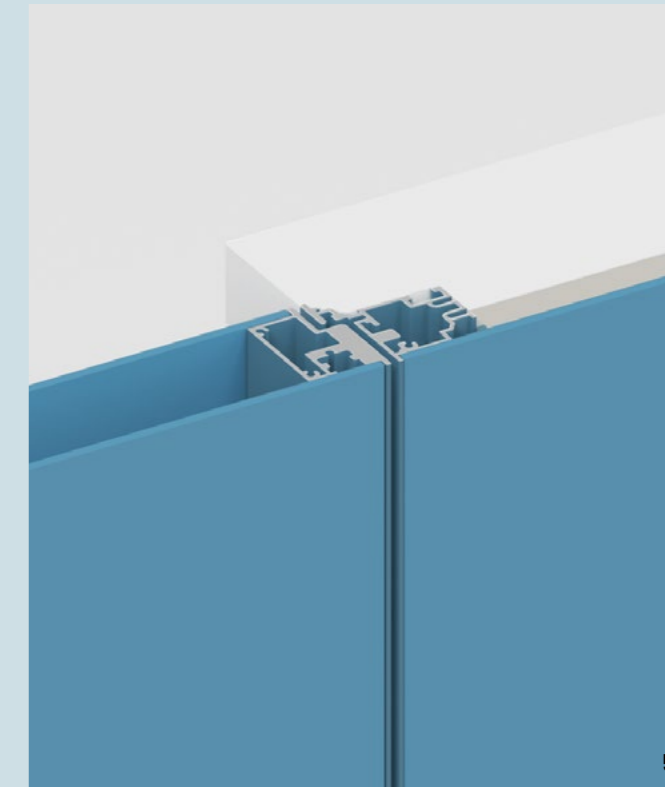

**5. Sezione orizzontale filomuro cerniere nascoste con Next doppio vetro a tirare e pannelli Boiserie a incollaggio**  
5. Horizontal section flush door with concealed hinges with Next double glass to pull and Boiserie panel system

**6. Sezione orizzontale filomuro cerniere nascoste con Next doppio vetro a spingere e pannelli Boiserie a incollaggio**  
6. Horizontal section flush door with concealed hinges with Next double glass to push and Boiserie panel system



# Filomuro cerniere nascoste (58mm | Next)

## Flush door with concealed hinges (58mm | Next)

Lo stipite "filomuro con cerniere nascoste" per pannelli da 58mm | Next permette di realizzare la classica porta a filomuro, pressochè invisibile sulla parete con pannelli in legno di forte spessore. La versione a tirare di questa porta è caratterizzata da una doppia battuta, che, insieme al pannello maggiorato da 58mm, garantiscono un isolamento acustico superiore e una forte sensazione di consistenza del prodotto. Le cerniere a scomparsa sono incassate all'interno dello stipite e del pannello porta permettendo una completa coplanarità tra porta e parete senza alcuna presenza visibile. L'effetto che si ottiene è di estrema pulizia. Albed utilizza cerniere certificate, regolabili sui 3 assi.

The "flush door with concealed hinges" jamb for panels 58mm | Next thickness allows to realize the classic flush to the wall door, almost invisible on the wall, with wood panels of considerable thickness. The version "to pull" of this door is characterized by a double frame that together with the increased panel of 60 mm provides better soundproofing and a strong sensation of consistency of the product. The concealed hinges are built-in the jamb and the door panel allowing complete coplanarity between door and wall without any visible presence. Albed uses certified hinges that can be adjusted on three axes.

### Porta singola / Single door

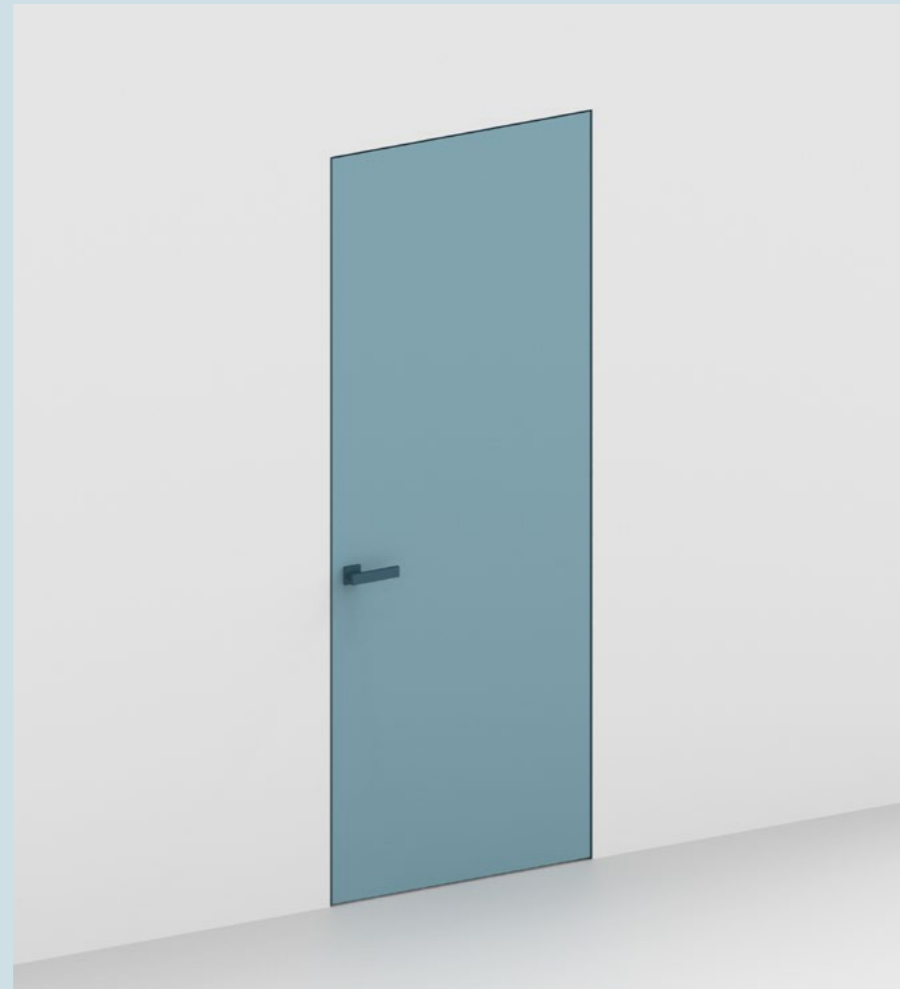

**Porta singola a tirare**  
Single pull door

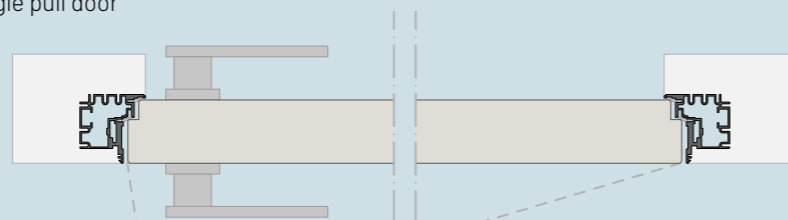

**Porta singola a spingere**  
Single push door

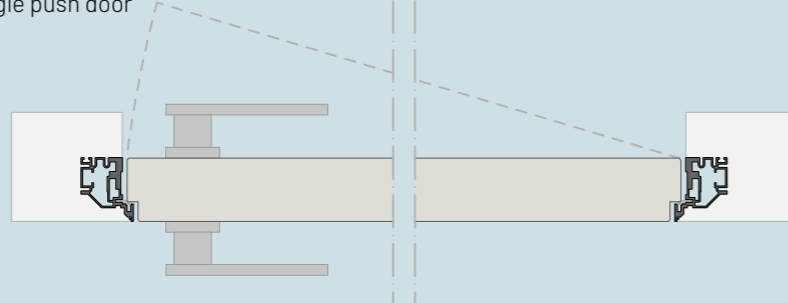

### Porta a due ante / Double door



**Porta a due ante asimmetriche a tirare**  
Asymmetrical double pull door

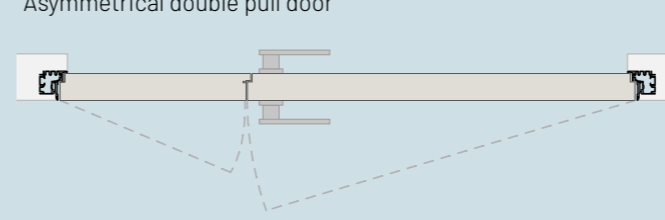

**Porta a due ante simmetriche a tirare**  
Symmetrical double pull door

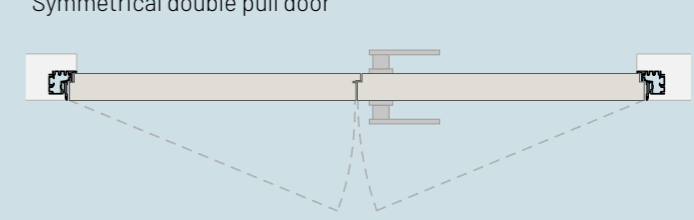

**Porta a due ante asimmetriche a spingere**  
Asymmetrical double push door

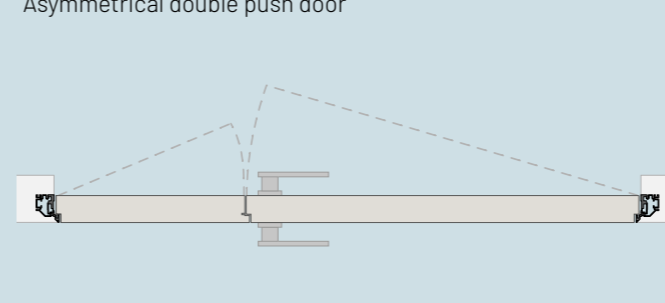

**Porta a due ante simmetriche a spingere**  
Symmetrical double push door

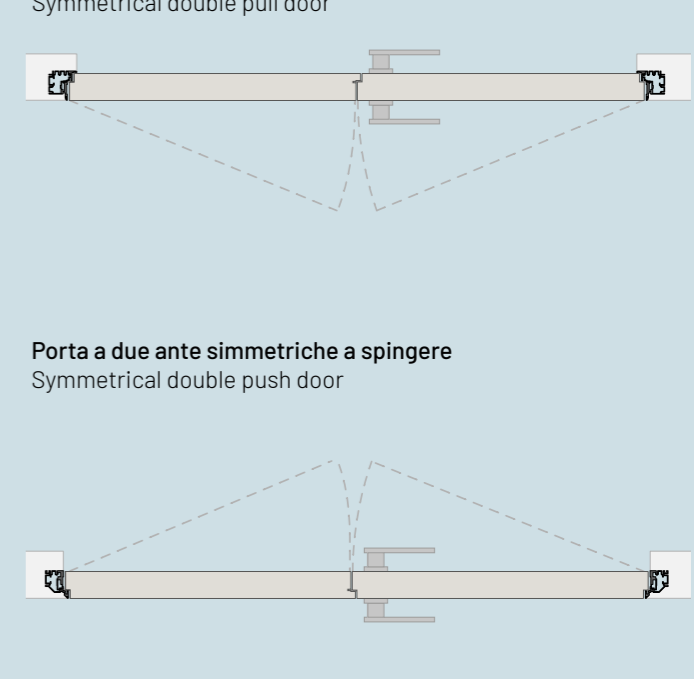

# Filomuro cerniere nascoste (58mm | Next)

## Flush door with concealed hinges (58mm | Next)

### Compatibilità / Compatibilities

### Dettagli / Details

#### Next 58mm

P. 106

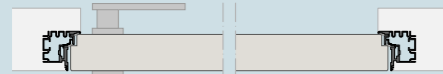

Next 58mm pannello legno a tirare  
Wooden panel Next 58mm to pull



Next 58mm pannello legno a spingere  
Wooden panel Next 58mm to push



Next 58mm pannello EI30 a tirare  
EI30 panel Next 58mm to pull



Next 58mm pannello EI30 a spingere  
EI30 panel Next 58mm to push

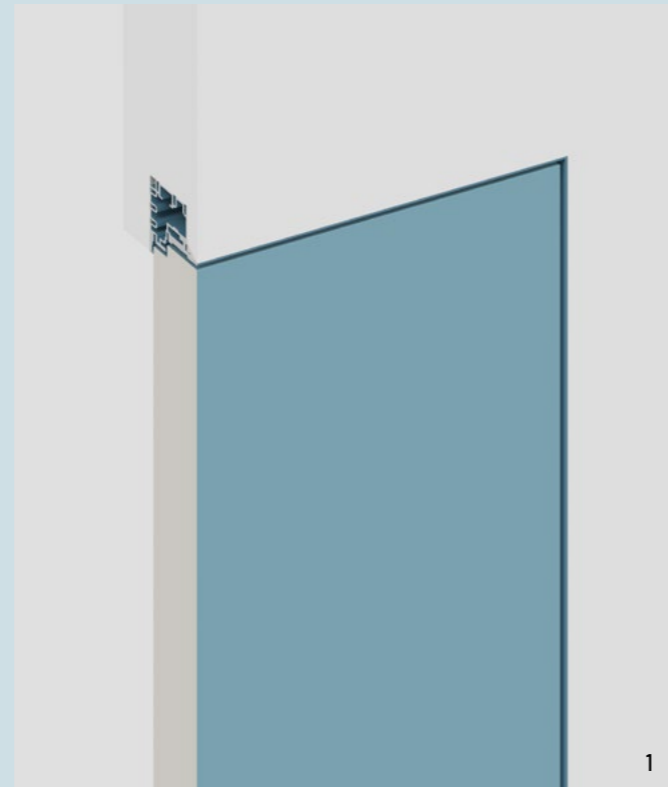

1

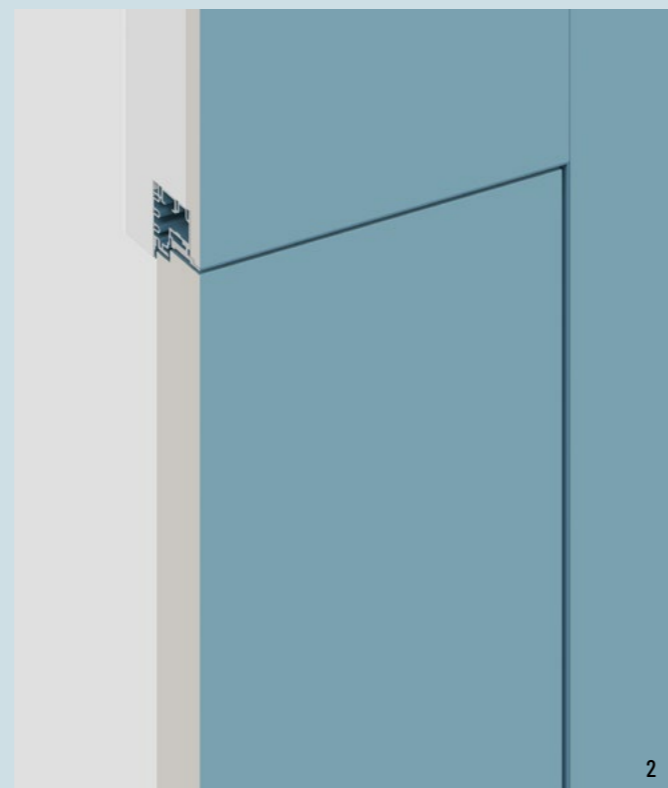

2

1. Sezione verticale filomuro cerniere nascoste (stipite su tre lati) con Next pannello legno a tirare

1. Vertical section flush door with concealed hinges (jamb on three sides) with wooden panel Next to pull

2. Sezione verticale filomuro cerniere nascoste (stipite su tre lati) con Next pannello legno a tirare e pannelli Boiserie a incollaggio

2. Vertical section flush door with concealed hinges (jamb on three sides) with wooden panel Next to pull and Boiserie panel system

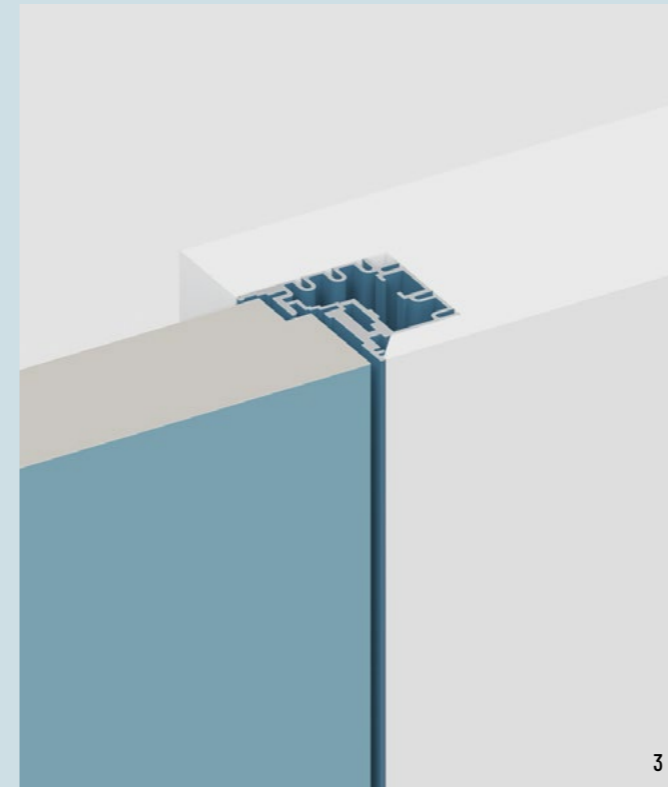

3

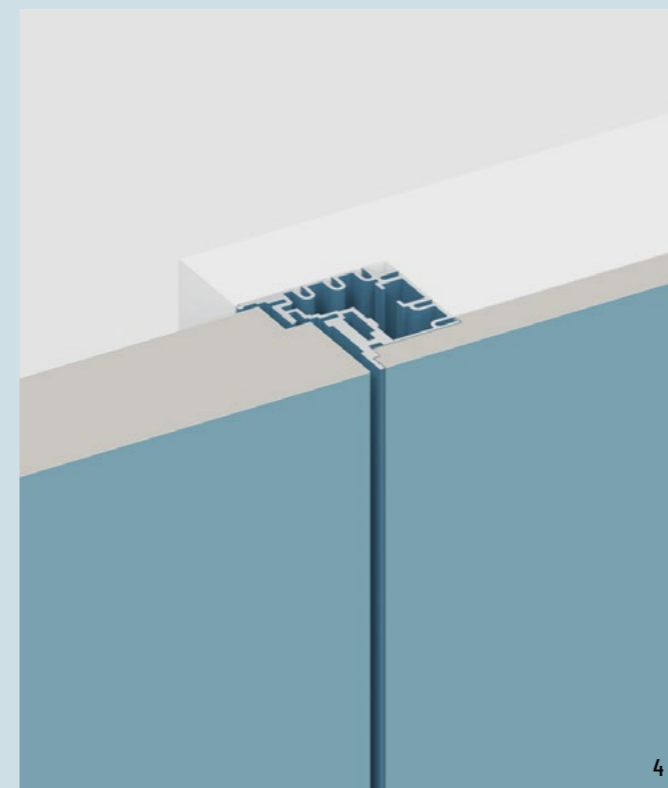

4

3. Sezione orizzontale filomuro cerniere nascoste con Next pannello legno a tirare

3. Horizontal section flush door with concealed hinges with wooden panel Next to pull

4. Sezione orizzontale filomuro cerniere nascoste con Next pannello legno a tirare e pannelli Boiserie a incollaggio

4. Horizontal section flush door with concealed hinges with wooden panel Next to pull and Boiserie panel system

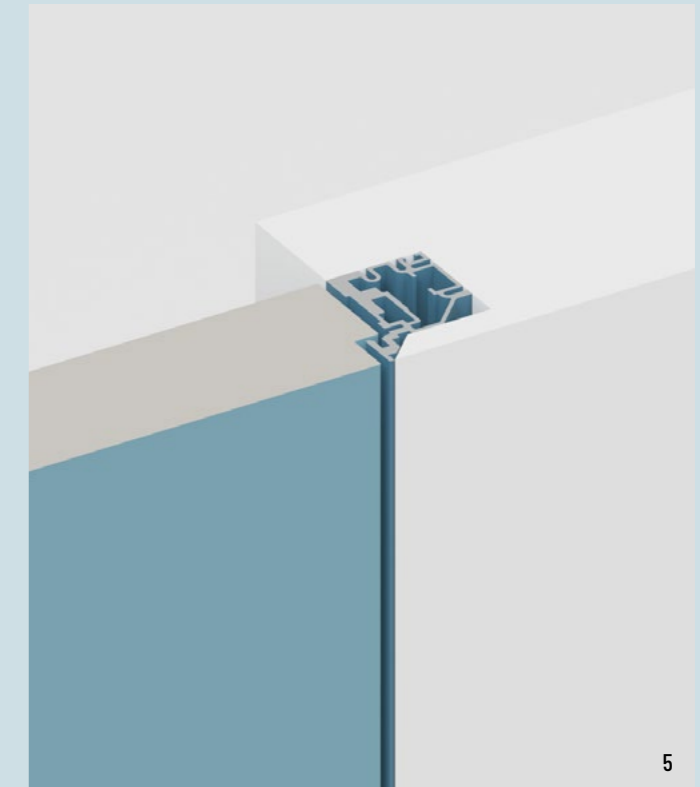

5

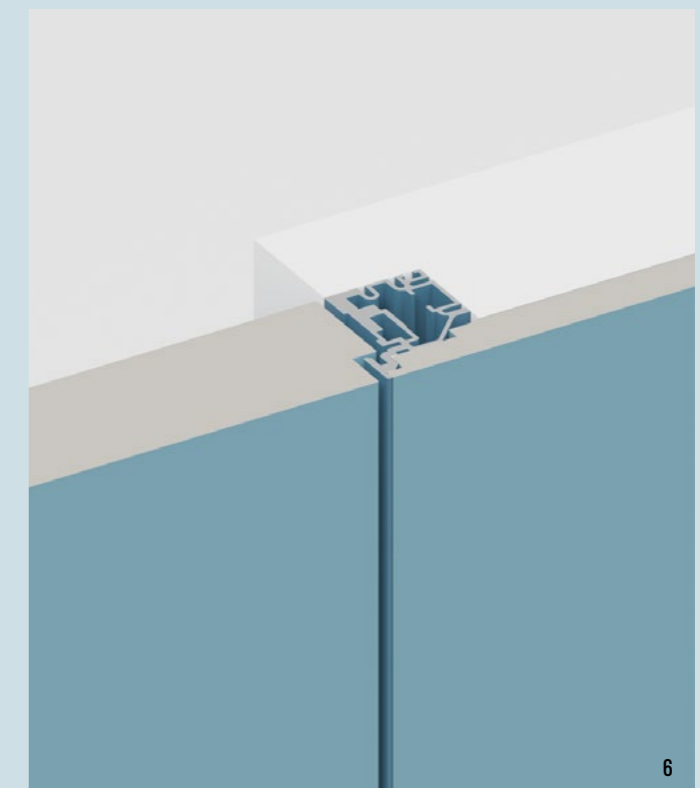

6

5. Sezione orizzontale filomuro cerniere nascoste con Next pannello legno a spingere

5. Horizontal section flush door with concealed hinges with wooden panel Next to push

6. Sezione orizzontale filomuro cerniere nascoste con Next pannello legno a spingere e pannelli Boiserie a incollaggio

6. Horizontal section flush door with concealed hinges with wooden panel Next to push and Boiserie panel system



# Filomuro cerniere invisibili (60mm | Suit)

## Flush door with concealed hinges (60mm | Suit)

Lo stipite "filomuro con cerniere nascoste" per pannelli da 60mm | Suit permette di realizzare la classica porta a filomuro, pressochè invisibile sulla parete. Questo stipite si distingue per un disegno della battuta fortemente raccordata privo di spigoli che garantisce risultati estetici inconsueti per porte di questo spessore. La combinazione tra stipite, attrezzato con cerniere invisibili ad alto carico, e il pannello Suite, caratterizzato da una cornice in alluminio quasi invisibile, permette di rivestire questa porta con lastre ceramiche o di altri materiali pesanti fino a 6mm di spessore senza alcuna difficoltà. Le cerniere a scomparsa sono incassate all'interno dello stipite e del pannello porta permettendo una completa coplanarità tra porta e parete senza alcuna presenza visibile. L'effetto che si ottiene è di estrema pulizia. Albed utilizza cerniere certificate, regolabili sui 3 assi.

The "flush door with concealed hinges" jamb for panels 60mm | Suit thickness allows to realize the classic flush to the wall door, almost invisible on the wall. This jamb has a design that guarantees unusual aesthetic results for doors with this thickness. The combination of jamb, equipped with invisible hinges with high performance in terms of capacity, and the door panel Suite, characterized by an almost invisible aluminum frame, allows to cover this door with ceramic slabs or other heavy materials up to 6 mm thickness without any difficulty. The concealed hinges are built-in the jamb and the door panel allowing complete coplanarity between door and wall without any visible presence. Albed uses certified hinges that can be adjusted on three axes.

### Porta singola / Single door

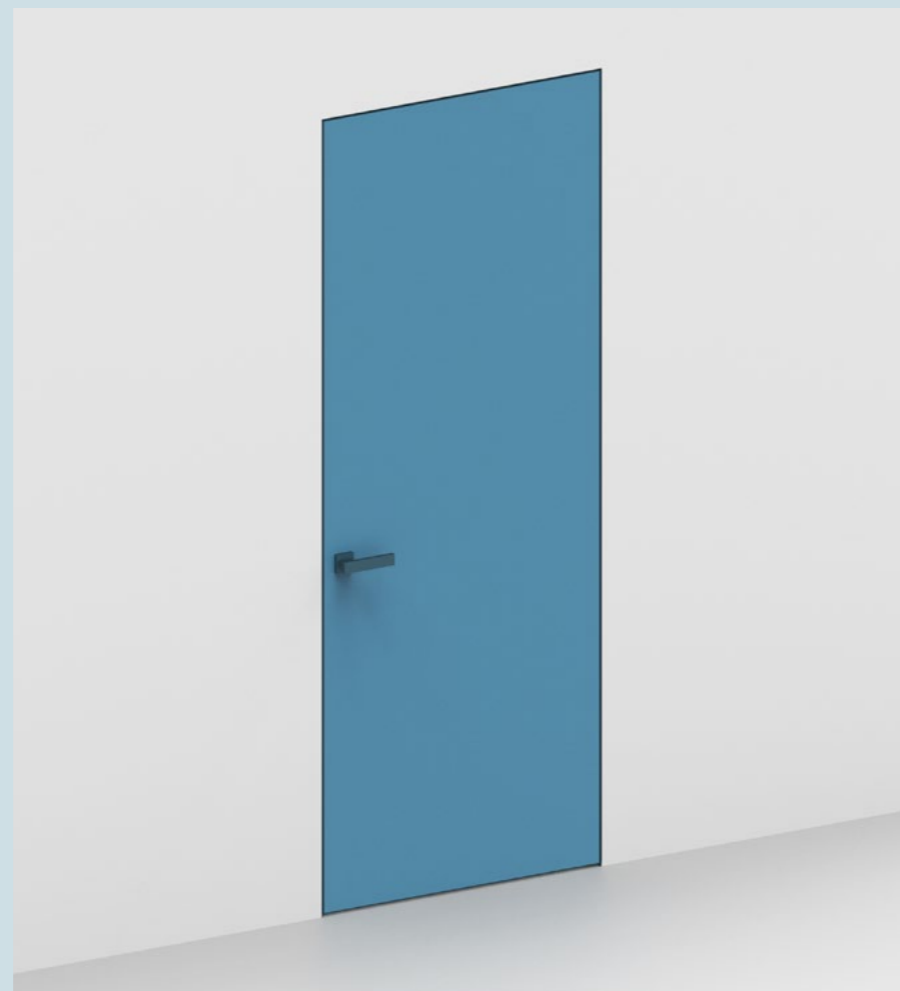

**Porta singola a tirare**  
Single pull door

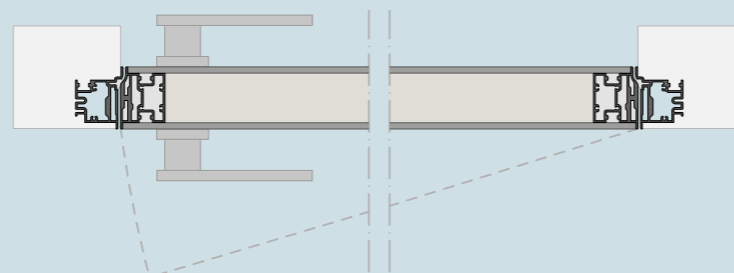

**Porta singola a spingere**  
Single push door

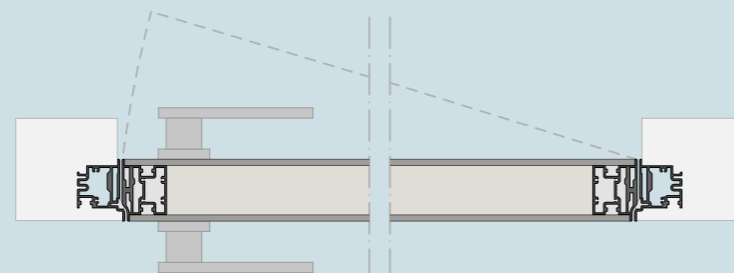

### Porta a due ante / Double door



**Porta a due ante asimmetriche a tirare**  
Asymmetrical double pull door

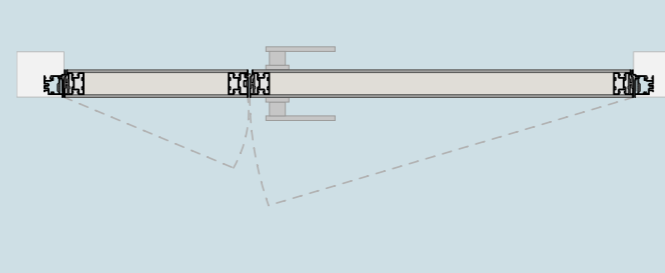

**Porta a due ante asimmetriche a spingere**  
Asymmetrical double push door

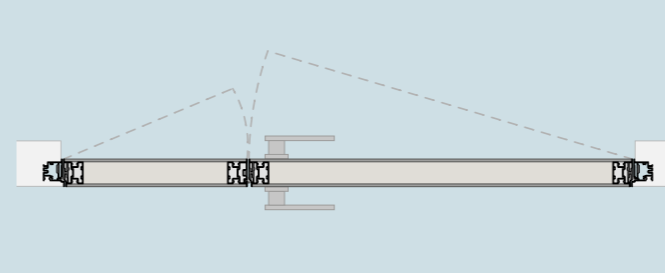

**Porta a due ante simmetriche a tirare**  
Symmetrical double pull door

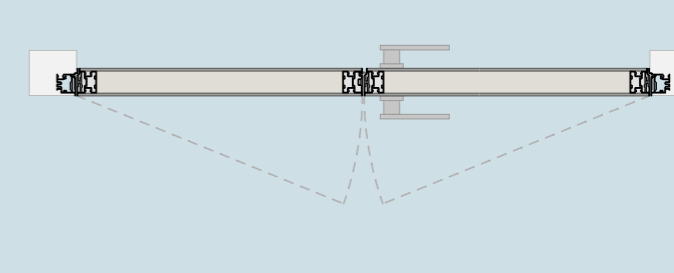

**Porta a due ante simmetriche a spingere**  
Symmetrical double push door

# Filomuro cerniere invisibili (60mm | Suit)

## Flush door with concealed hinges (60mm | Suit)

### Dettagli / Details

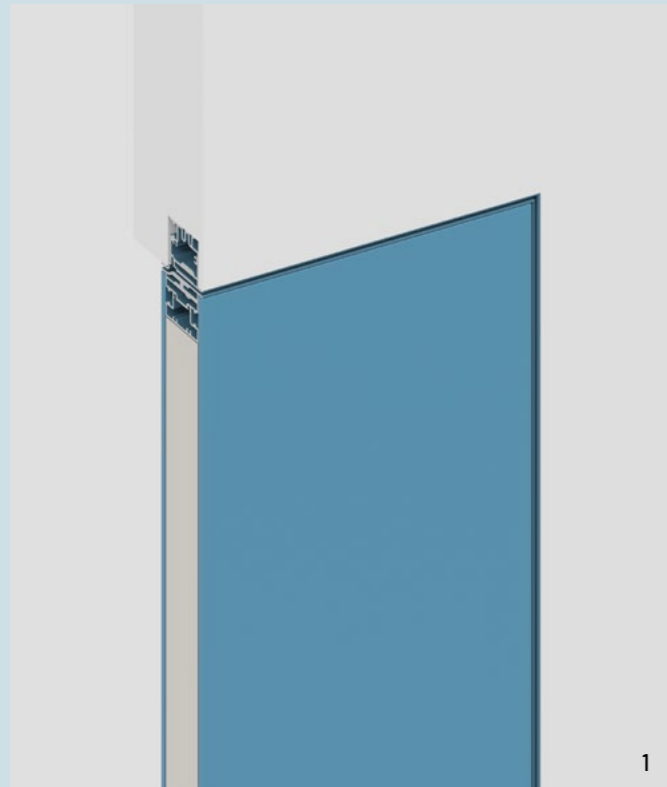

1

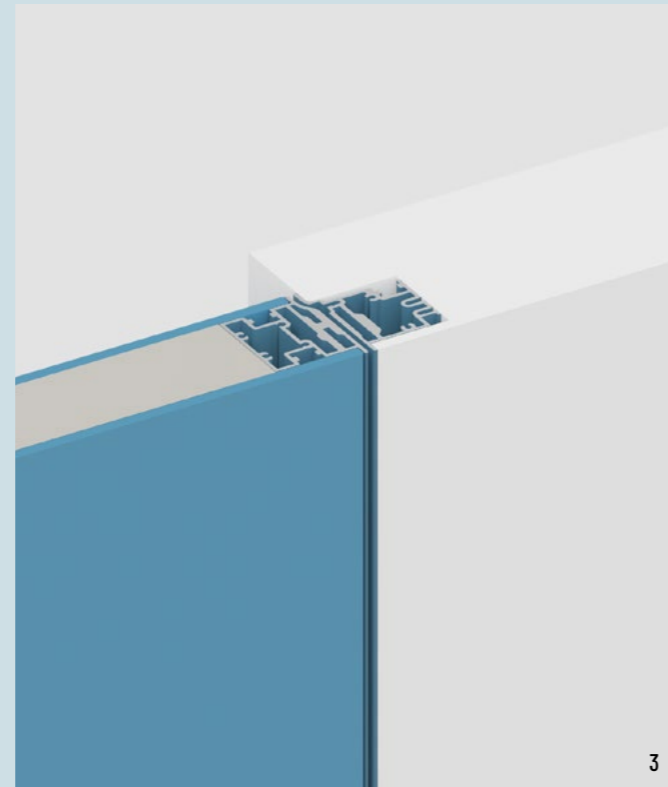

3

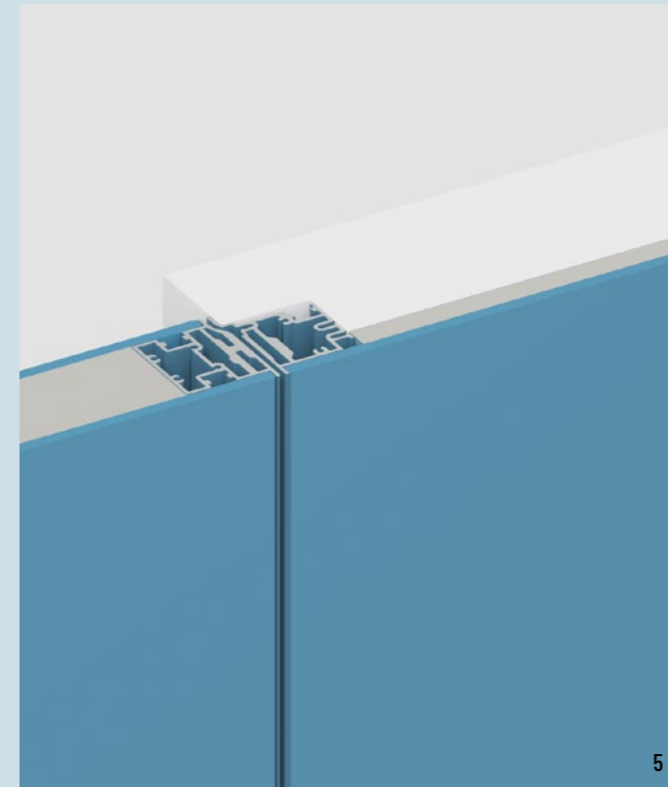

5

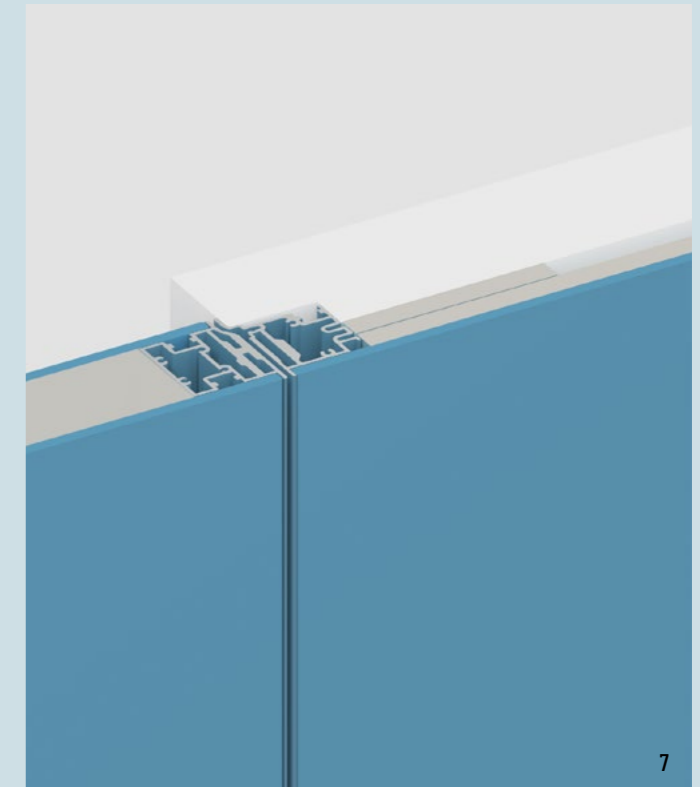

7

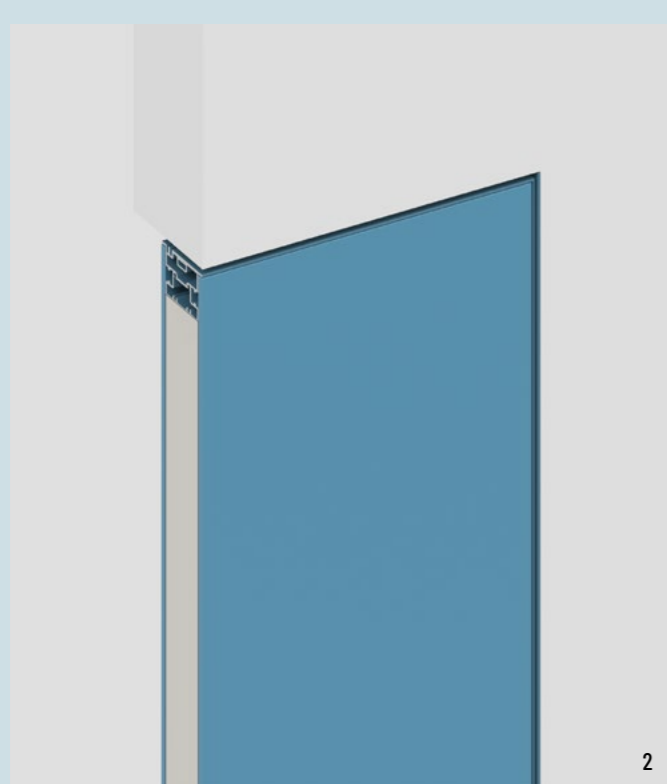

2

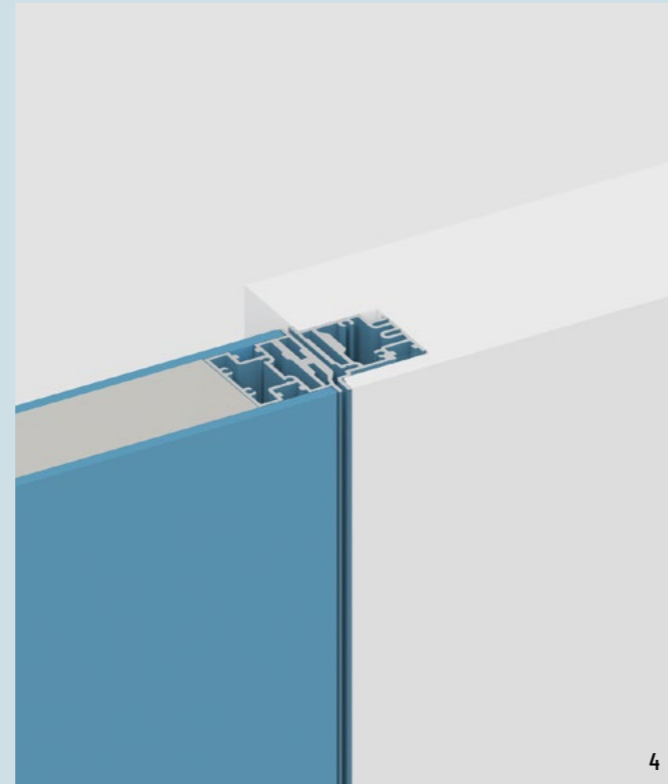

4

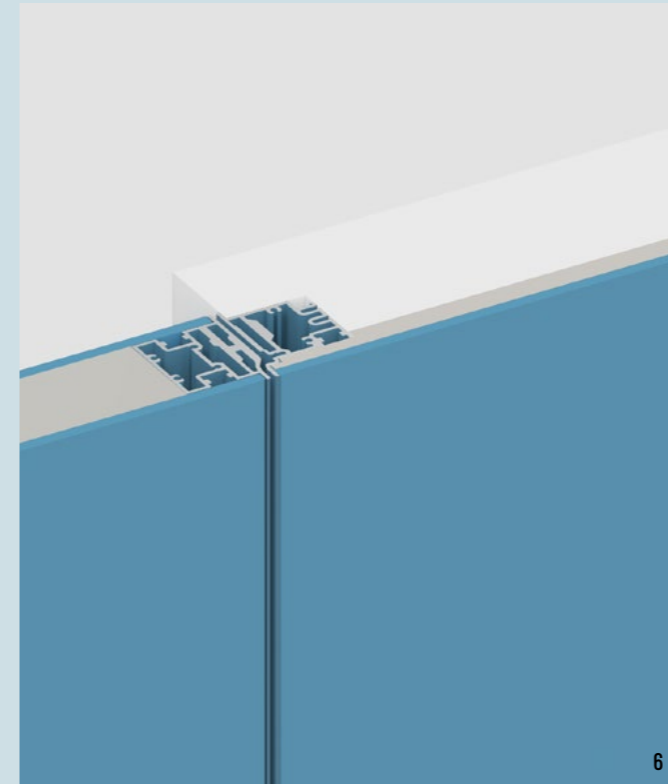

6

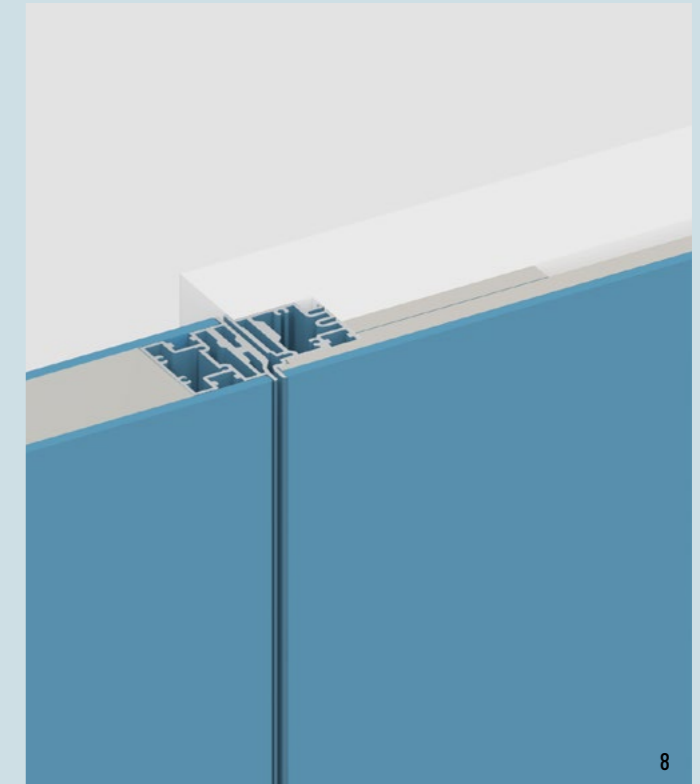

8

**1. Sezione verticale filomuro cerniera nascosta (stipite su tre lati) con Suit telaio alluminio a tirare**

1. Vertical section flush door with concealed hinges (jamb on three sides) with aluminium frame Suit to pull

**2. Sezione verticale filomuro cerniera nascosta (tutta altezza) con Suit telaio alluminio a tirare o a spingere**

2. Vertical section flush door with concealed hinges (full height) with aluminium frame Suit to pull or to push

**3. Sezione orizzontale filomuro cerniera nascosta con Suit telaio alluminio a tirare**

3. Horizontal section flush door with concealed hinges with aluminium frame Suit to pull

**4. Sezione orizzontale filomuro cerniera nascosta con Suit telaio alluminio a spingere**

4. Horizontal section flush door with concealed hinges with aluminium frame Suit to push

**5. Sezione orizzontale filomuro cerniera nascosta con Suit telaio alluminio a tirare e sistema Boiserie Albed**

5. Horizontal section flush door with concealed hinges with aluminium frame Suit to pull and Boiserie gluing panels

**6. Sezione orizzontale filomuro cerniera nascosta con Suit telaio alluminio a spingere e sistema Boiserie Albed**

6. Horizontal section flush door with concealed hinges with aluminium frame Suit to push and Boiserie gluing panels

**7. Sezione orizzontale filomuro cerniera nascosta con Suit telaio alluminio a tirare e sistema Boiserie Albed**

7. Horizontal section flush door with concealed hinges with aluminium frame Suit to pull and Boiserie mounting Albed system

**8. Sezione orizzontale filomuro cerniera nascosta con Suit telaio alluminio a spingere e sistema Boiserie Albed**

8. Horizontal section flush door with concealed hinges with aluminium frame Suit to push and Boiserie mounting Albed system



# Filomuro bilico con battuta (60mm | Suit)

## Pivoting flush hinged door (60mm | Suit)

Lo stipite "filomuro bilico" per pannelli da 60mm | Suit permette di realizzare la classica porta a filomuro, quasi invisibile sulla parete, con un sistema di rotazione traslato.

Le cerniere sono incassate nella parte superiore e inferiore degli stipiti permettendo di ottenere a porta chiusa una completa complanarità tra pannello e parete senza alcuna presenza visibile. Questo stipite permette di ottenere un effetto estremamente pulito, in quanto le cerniere di rotazione non sono mai visibili, nemmeno a porta aperta. La rotazione traslata rispetto alla fine del pannello, inoltre, consente di ottenere l'ingombro di rotazione della porta. Si distingue per un disegno della battuta fortemente raccordato, privo di spigoli, che garantisce risultati estetici inconsueti per porte di questo spessore.

The "pivoting flush door" jamb for 60mm | Suit thickness panels/Suit allows to realize the classic flush to the wall door, almost invisible on the wall, with a traslated rotation system.

The hinges are built in the upper and lower part of the jambs allowing to obtain a complete coplanarity between door and wall without any visible presence. This jamb allows to obtain an extremely clean effect, because the hinges of rotation are never visible, even when the door is open. The rotation shifted from the end of the panel, moreover, allows to obtain the bulk of rotation of the door. It stands out for a design of the frame strongly connected, free of edges, which guarantees unusual aesthetic results for doors of this thickness.

### Porta singola / Single door

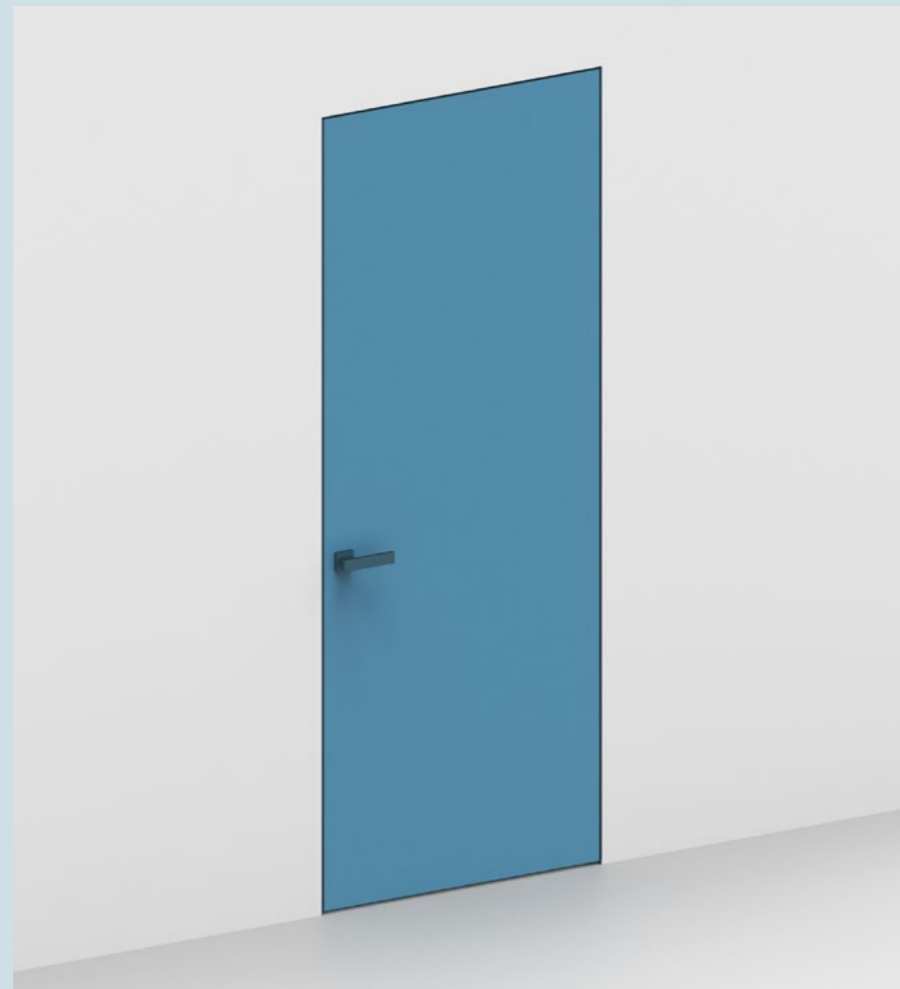

**Porta singola a tirare**  
Single pull door

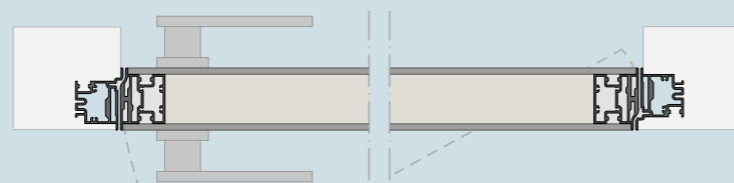

**Porta singola a spingere**  
Single push door

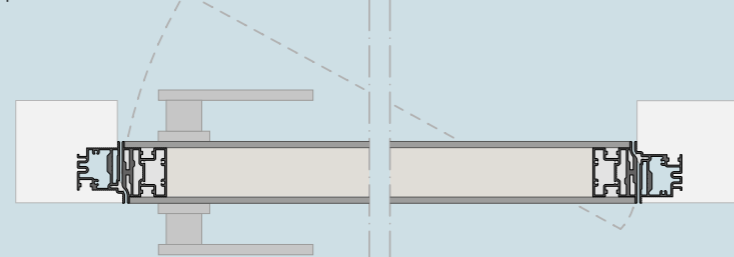

### Compatibilità / Compatibilities

#### Suit

P. 114

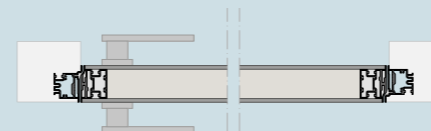

**Suit telaio alluminio a tirare**  
Aluminium frame Suit to pull

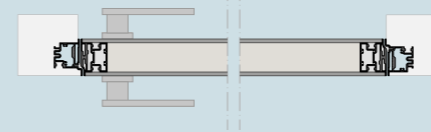

**Suit telaio alluminio a spingere**  
Aluminium frame Suit to push

### Dettagli / Details

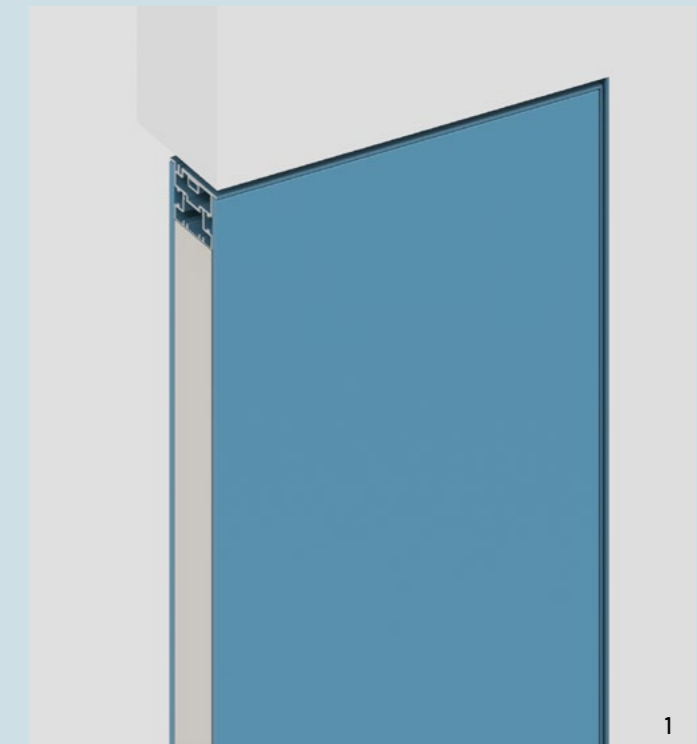

1

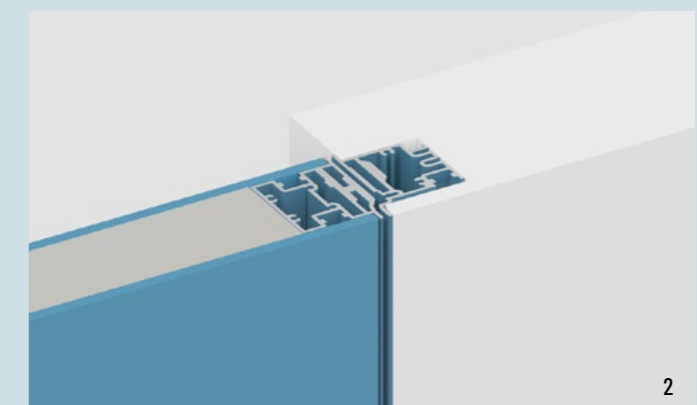

2

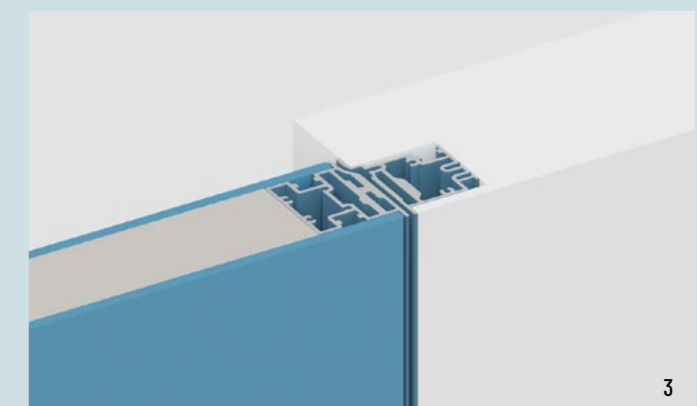

3

**1. Sezione verticale porta filomuro bilico con Suit telaio alluminio**  
1. Horizontal section pivoting flush door with aluminium frame Suit

**2. Sezione orizzontale porta filomuro bilico con Suit telaio alluminio**  
2. Horizontal section pivoting flush door with aluminium frame Suit

**3. Sezione orizzontale porta filomuro bilico con Suit telaio alluminio**  
3. Horizontal section pivoting flush door with aluminium frame Suit

# Suit filomuro

## Suit flush door

### 1 PORTE SINGOLE STANDARD / STANDARD SINGLE DOORS

Tipo pannello Panel type	Finitura pannello Panel finishing	Finitura stipite e telaio pannello Jamb and frame panel finishing	Filomuro cerniere nascoste Flush door with concealed hinges	Filomuro bilico con battuta Pivoting flush hinged door
			Stipite su 3 lati Jamb on 3 sides	Tutta altezza All height
Telaio alluminio Aluminium frame	Predisposto per lastra da 6mm* Designed for 6mm boards*	Finitura alluminio anodizzato o RAL 9003 Anodized aluminum finishing or RAL 9003	€ 1.590	€ 1.590
				€ 1.470

\*Peso massimo totale delle lastre: 130kg  
\*Total maximum plates weight: 130kg

### DIMENSIONI STANDARD / STANDARD SIZES

Porta singola Single door	Pannelli standard Standard panels	Luce passaggio Passage clearance
Porta con cerniere a tirare Hinged door to pull	L 705/805/905 x H 2095	L 700/800/900 x H 2100
Porta con cerniere a spingere Hinged door to push	L 705/805/905 x H 2095	L 700/800/900 x H 2100
Porta bilico Pivoting door	L 705/805/905 x H 2095	L 700/800/900 x H 2100

Al momento dell'ordine specificare il senso di apertura: tirare o spingere e sinistra o destra  
When ordering, specify the opening side of the door: pull or push and left or right.

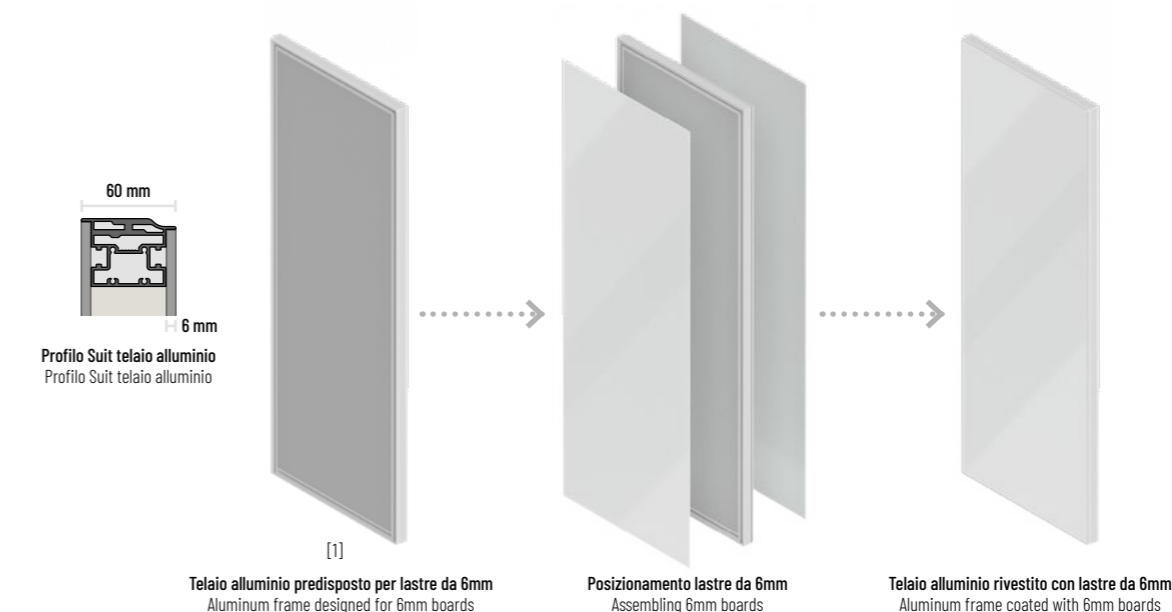

### 2 DIMENSIONI CUSTOM / CUSTOM SIZES

Tipo pannello Panel type	Luce passaggio: Passage clearance:	L < 1000
	H < 2400	+ € 170
Telaio alluminio Aluminium frame	H < 2700	+ € 230
	H < 3000	+ € 290

Per qualsiasi larghezza custom luce passaggio fino a L 1000 (per porta singola) o fino a L 2000 (per porta a due ante)  
For any custom width for passage clearance up to L 1000 (for single door) or up to L 2000 (for double door)

\*per H < 2400 peso massimo totale delle lastre: 100kg  
\*for H < 2400 total maximum plates weight: 100kg

### 3 FINITURE LASTRE / BOARDS FINISHINGS

Tipo pannello Panel type	Finitura lastra 6mm 6mm board finishing	P. 30
	Con fondo / Con fondo	+ 15%
	Laccato standard Standard lacquered	+ 25%
Telaio alluminio Aluminium frame	Laccato custom RAL Custom RAL lacquered	+ 35%
	Essenza legno Wood essence	+ 47%
	Vetro opaco Opaque glass	Cat.C + 30% Cat.D + 35%
	Cuoio Leather	+ 50%

Selezionare una lastra per ogni faccia della porta.  
Al momento dell'ordine specificare quale lastra debba essere posizionata sulla faccia anteriore e quale sulla faccia posteriore.  
Select a board for each face of the door  
When ordering, specify which board have to be positioned on the front face and which on the back face.

### 4 PORTE A DUE ANTE / DOUBLE DOORS

Tipo pannello Panel type	Porta a due ante Double door	
	Due ante asimmetriche* Asymmetrical double door*	+ 80%
Telaio alluminio Aluminium frame	Due ante simmetriche* Symmetrical double door*	+ 90%

Porta a due ante disponibili con luce passaggio fino a L2000  
Double doors available with passage clearance up to L2000

Porta a due ante asimmetriche è formata da un pannello porta L805 + un pannello semifisso di L tale da riempire la luce passaggio  
Symmetrical double door is made up from a door panel L805 + a semi-fixed panel of Width such as to fill the passage clearance.

Porta a due ante simmetriche è formata da due pannelli di Larghezza uguale  
Symmetrical double door is made up of two panels of equal Width

### 5 SISTEMI DI CHIUSURA / CLOSING SYSTEMS

Tipo pannello Panel type	Sistema di chiusura Closing system	Senza blocco Whitout block	Chiave Patent Patent key	Nottolino Latch free/busy	Chiave Yale Yale key
Telaio alluminio Aluminium frame	Serr. scrocco magn. per maniglia standard Lock with magnetic latch for standard handles	+ € 90 *	+ € 45	+ € 45	+ € 55 **

\* il prezzo comprende serratura e opzione "solo foro maniglia"  
\* price includes lock and "handle hole only" option

\*\* il prezzo non comprende il cilindro Yale  
\*\* price does not include Yale cylinder

### 6 MANIGLIE / HANDLES

Tipo pannello Panel type	Sistema di chiusura Closing system	Maniglia Handle	Chiave Patent Patent key	Chiave Patent Patent key	Nottolino Latch free/busy	Chiave Yale Yale key
		Etna	+ € 190	+ € 190	+ € 210	+ € 190
		Vesuvio*	+ € 230	+ € 230	+ € 250	+ € 230
Telaio alluminio Aluminium frame	Serr. scrocco magnetico per maniglia standard Lock with magnetic latch for standard handles	Vulcano	+ € 190	+ € 190	+ € 210	+ € 190
		Fuji	+ € 80	+ € 80	+ € 110	+ € 80
		Teide	+ € 80	+ € 80	+ € 110	+ € 80

\* Al momento dell'ordine specificare la scelta tra rosetta e bocchetta quadrate o tonde  
\* When ordering, specify the choice between square or round rosettes and escutcheon

### 7 ACCESSORI PORTA / DOOR ACCESSORIES

Accessorio Accessory	Pagina listino Page price book
Accessori porta Door accessories	P. 141

### 8 BOISERIE / BOISERIE

Tipologia Typology	Sistema System	Pagina listino Page price book
Boiserie Boiserie	Pannelli incollaggio Gluing panels	P. 284
	Sistema montaggio Albed Mounting Albe system	P. 288

### CODICI PORTE / DOORS CODES

Tipo pannello Panel Type	Tipo stipite Jamb Type	Filomuro cerniere nascoste Flush door with concealed hinges									Filomuro bilico con battuta Pivoting flush hinged door				
		Porta singola / Single door				Porta a due ante / Double door					Porta singola / Single door				
		Tirare / Pull		Spingere / Push		Tirare / Pull		Spingere / Push			Tirare / Pull		Spingere / Push		
		Sinistra Left	Destra Right	Sinistra Left	Destra Right	Anta princ. sx / Left main door	Anta princ. dx / Right main door	Simmetrica Symmet- rical	Anta princ. sx / Left main door	Anta princ. dx / Right main door	Simmetrica Symmet- rical	Sinistra Left	Destra Right	Sinistra Left	Destra Right
[1]	Stipite su 3 lati Jamb on 3 sides	STRV 001	STRV 002	STRV 005	STRV 006	STRV 009	STRV 010	STRV 011	STRV 015	STRV 016	STRV 017	-	-	-	-
	Tutta altezza All height	STRV 003	STRV 004	STRV 007	STRV 008	STRV 012	STRV 013	STRV 014	STRV 018	STRV 019	STRV 020	STRU 001	STRU 002	STRU 003	STRU 004

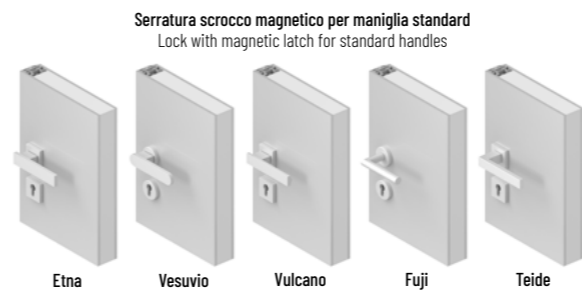

### CODICI SISTEMI DI CHIUSURA / CLOSING SYSTEMS CODES

Sistema di chiusura Closing system	Senza blocco Without block	Chiave Patent Patent key	Nottolino Latch free/busy	Chiave Yale Yale key
Serr. scrocco magnetico per maniglia standard Lock with magnetic latch for standard handles	LV-PS1	LV-PS1	LV-PS2	LV-PS3

Configurazioni serratura scrocco magnetico per maniglia standard Lock with magnetic latch for standard handles configurations	Senza blocco Whitout block	Chiave Patent Patent key	Nottolino Latch free/busy	Chiave Yale Yale key

### CODICI MANIGLIE / HANDLES CODES

Maniglia Handle	Solo maniglia Only handle	Chiave Patent Patent key	Nottolino Latch free/busy	Chiave Yale Yale key
Etna	AC-350C	AC-350C	AC-350N	AC-350Y
Vesuvio*	AC-550C	AC-550C	AC-550N	AC-550Y
Vesuvio**	AC-555C	AC-555C	AC-555N	AC-555Y
Vulcano	AC-450C	AC-450C	AC-450N	AC-450Y
Fuji***	AC-120C	AC-120C	AC-120N	AC-120Y
Teide***	AC-220C	AC-220C	AC-220N	AC-120Y

\* Versione con rosetta e bocchetta quadrate / Square rosette and escutcheon version

\*\* Versione con rosetta e bocchetta tonde / Circular rosette and escutcheon version

\*\*\* Disponibile solo in finitura acciaio / Available only in steel finish

# Filomuro ambo i lati (105mm 125mm)

## Door flush on both sides (105mm or 125mm)

Lo stipite "filomuro ambo lati" è la soluzione ideale quando si vuole avere la complanarità della porta su entrambi i prospetti della parete. Albed è stata la prima azienda a produrre una soluzione di serie per risolvere questa necessità progettuale. Questo prodotto è adatto a pareti di spessore di 105mm o 125mm. Albed utilizza cerniere certificate, regolabili sui 3 assi.

The "door flush on both sides" jamb is the ideal solution when the door needs to be flush on both sides of the wall. Albed was the first company to produce a solution to solve this design necessity. This product is suitable for 125 mm or 105 mm wall thickness. Albed uses certified hinges that can be adjusted on three axes.

### Porta singola / Single door

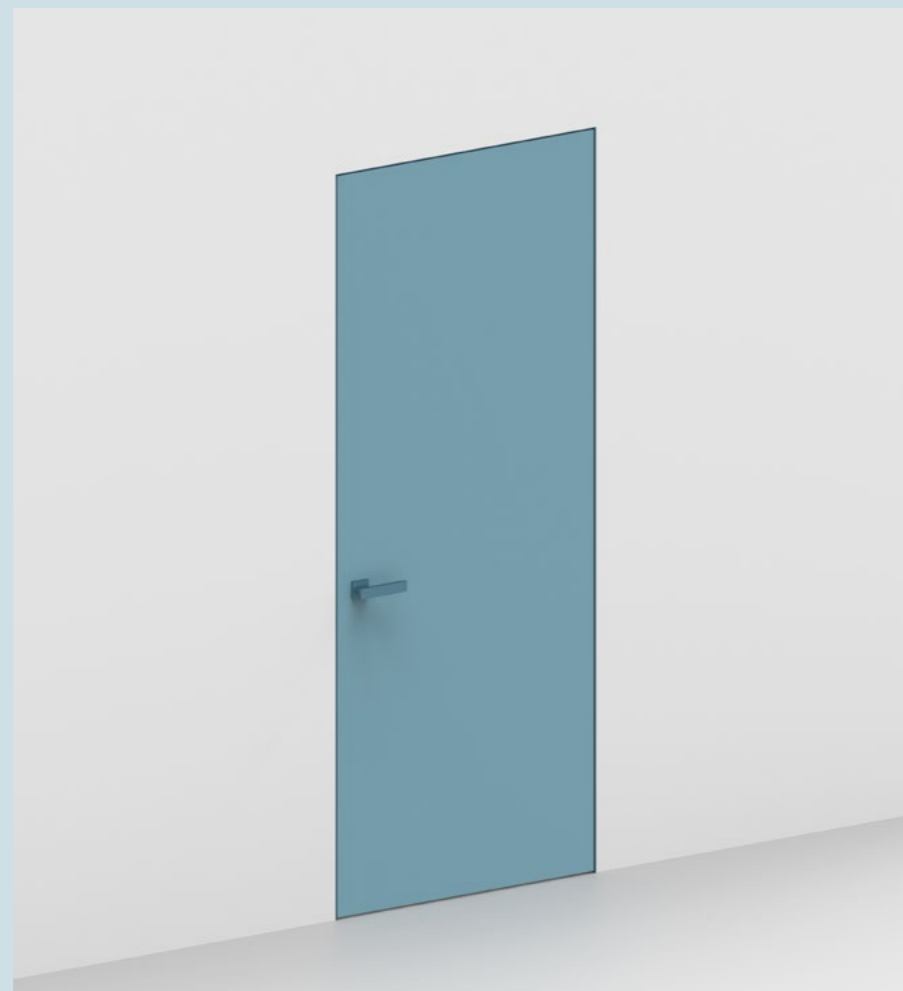

Porta singola 105 mm  
Single door 105mm

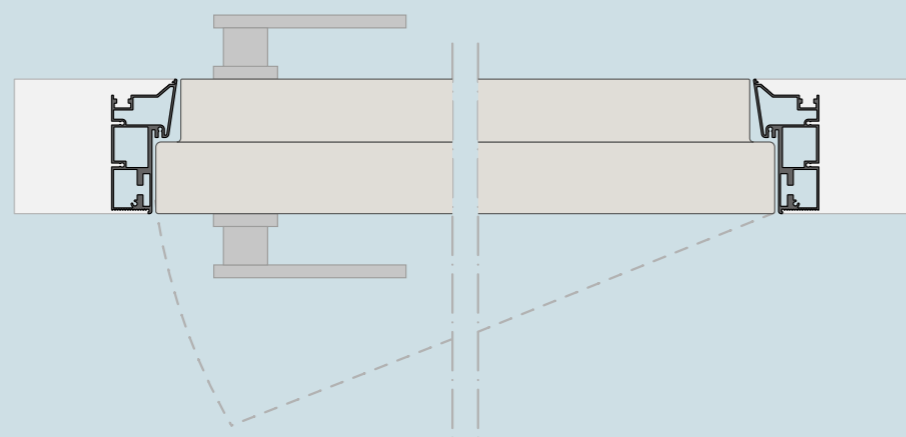

### Compatibilità / Compatibilities

#### Integra

P. 118

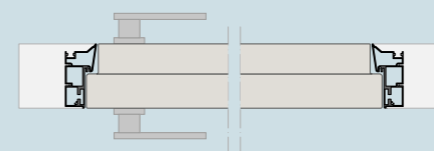

Integra pannello legno 105mm  
Wooden panel Integra 105mm

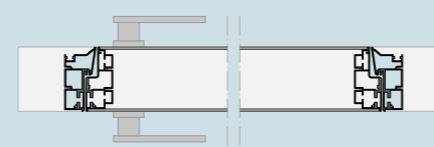

Integra telaio alluminio 105mm  
Aluminium frame Integra 105mm

### Dettagli / Details

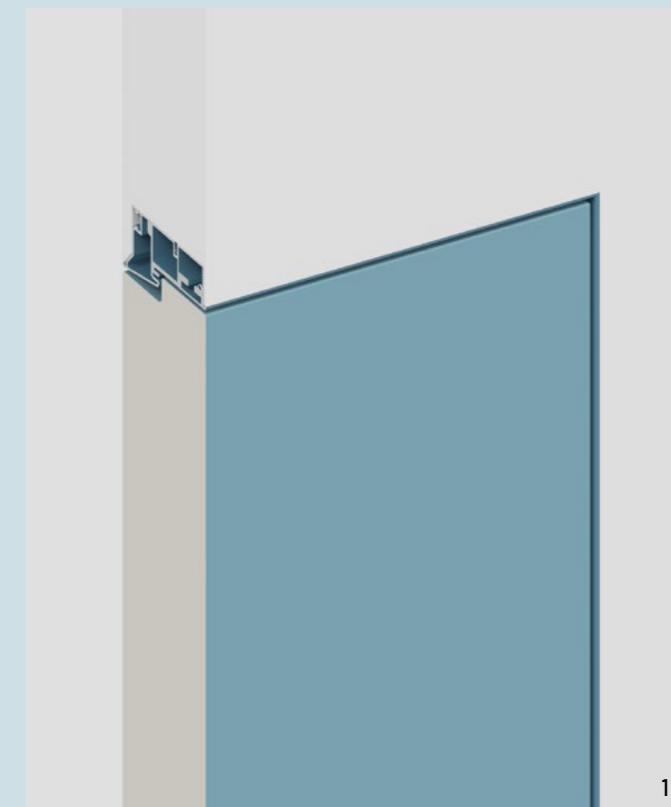

1

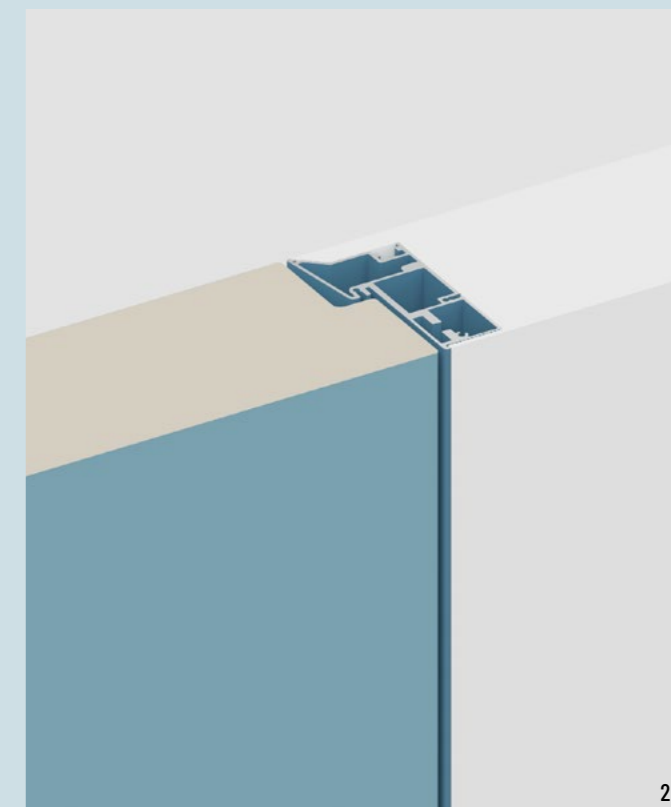

2

1. Sezione verticale filomuro ambo lati con Integra pannello legno (105mm)  
1. Vertical section door flush on both sides with Integra wooden panel (105mm)

2. Sezione orizzontale filomuro ambo lati con Integra pannello legno (105mm)  
2. Horizontal section door flush on both sides with Integra wooden panel (105mm)

# Integra

## 1 PORTE SINGOLE STANDARD / STANDARD SINGLE DOORS

Tipo pannello Panel type	Finitura pannello Panel finishing	Finitura stipite e telaio pannello Jamb and frame panel finishing	Spessore pannello Panel thickness	Filomuro ambo i lati Flush door on both sides	
				Stipite su 3 lati Jamb on 3 sides	Tutta altezza All height
Pannello legno Wooden panel	[1] Laccato standard Standard lacquered	Bianco RAL 9003 White RAL 9003	105 mm	€ 2.190	€ 2.190
			125 mm	€ 2.190	€ 2.190
Telaio alluminio Aluminium frame	[2] Vetro opaco Cat. C Opaque glass Cat. C	Bianco RAL 9003 White RAL 9003	105 mm	€ 2.750	€ 2.750
			125 mm	€ 2.750	€ 2.750
Vision* Vision*	[3] Digital balck (lato tirare) Vetro opaco Cat. C (lato spingere) Digital balck (pull side) Opaque glass Cat. C (push side)	Bianco RAL 9003 White RAL 9003	105 mm	€ 3.550	€ 3.550
			125 mm	€ 3.550	€ 3.550

\*Monitor escluso: predisposto per monitor Samsung 32 pollici  
\*Monitor excluded: prepared for monitor Samsung 32 inch

## DIMENSIONI STANDARD / STANDARD SIZES

Porta singola Single door	Lato tirare Pull side	Lato spingere Push side	Luce passaggio Passage clearance
Stipite su 3 lati Jamb on 3 sides	L 732/832/932 x H 2110	L 694/794/894 x H 2088	L 700/800/900 x H 2100
Tutta altezza All height	L 732/832/932 x H 2088	L 694/794/894 x H 2088	L 700/800/900 x H 2100

Al momento dell'ordine specificare il senso di apertura:  
tirare o spingere e sinistra o destra  
When ordering, specify the opening side of the door:  
pull or push and left or right.

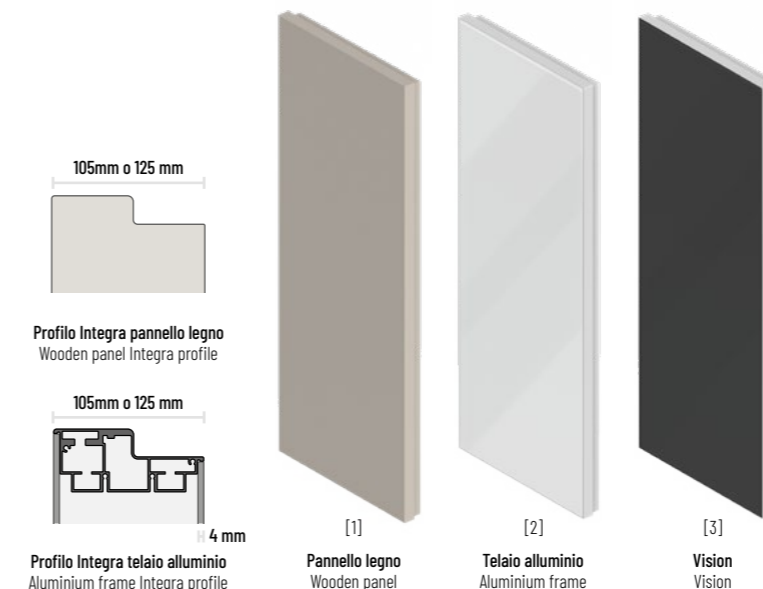

## 2 DIMENSIONI CUSTOM / CUSTOM SIZES

Tipo pannello Panel type	Luce passaggio: Passage clearance:	L < 1000
Pannello legno Wooden panel	H < 2200	+ € 300
	H < 2700	+ € 700
Telaio alluminio Aluminium frame	H < 2200	+ € 200
	H < 2700	+ € 800
Vision Vision	H < 2200	+ € 300
	H < 2700	+ € 900

Per qualsiasi larghezza custom luce passaggio fino a L 1000  
For any custom width for passage clearance up to L 1000

## 3 FINITURE / FINISHINGS

Tipo pannello Panel type	Finitura Finishing	P. 30
Pannello legno Wooden panel	Con fondo / With fund	- € 120
	Laccato custom RAL Custom RAL lacquered	+ € 200
	Essenza legno Wood essence	+ € 300
	Cartongesso / Drywall	- € 400
Telaio alluminio Aluminium frame	Personalizzabile* Customizable*	- € 300
	Vetro opaco Cat.D Opaque glass Cat.D	+ 10%
	Cuoio rigenerato Regenerated leather	+ € 250
	Cuoio / Leather	+ € 550
Vision Vision	Digital mirror (lato tirare) Digital mirror (pull side)	+ € 600
	Vetro opaco Cat.D (lato spingere) / Opaque glass Cat.D (push side)	+ 5%

\* pannello ribassato di 4mm per rivestimento cliente.  
\* 4mm lowered panel for customer coating.

Tipo elemento Element type	Finitura Finishing	P. 30
Stipite Jamb	Custom RAL Custom RAL	+ € 190
Telaio pannello Panel frame	Custom RAL Custom RAL	+ € 390

## 4 SISTEMI DI CHIUSURA / CLOSING SYSTEMS

Tipo pannello Panel type	Sistema di chiusura Closing system	Senza blocco Whitout block	Nottolino Latch free/busy	Chiave Yale Yale key
Tutti i pannelli All panels	Serratura scrocco magnetico per maniglia standard Lock with magnetic latch for standard handles	+ € 90 *	+ € 45	+ € 55 **

\* il prezzo comprende serratura e opzione "solo foro maniglia"  
\* price includes lock and "handle hole only" option

\*\* il prezzo non comprende il cilindro Yale  
\*\* price does not include Yale cylinder

## 5 MANIGLIE / HANDLES

Tipo pannello Panel type	Sistema di chiusura Closing system	Maniglia Handle	Senza blocco Whitout block	Nottolino Latch free/busy	Chiave Yale Yale key
Tutti i pannelli All panels	Serratura scrocco magnetico per maniglia standard Lock with magnetic latch for standard handles	Etna	+ € 190	+ € 210	+ € 190
		Vesuvio*	+ € 230	+ € 250	+ € 230
		Vulcano	+ € 190	+ € 210	+ € 190
		Fuji	+ € 80	+ € 110	+ € 80
		Teide	+ € 80	+ € 110	+ € 80

\* Al momento dell'ordine specificare la scelta tra rosetta e  
bocchetta quadrate o tonde  
\* When ordering, specify the choice between square or round  
rosettes and escutcheon

## CODICI PORTE / DOORS CODES

Tipo pannello Panel Type	Spessore pannello Panel thickness	Filomuro ambo i lati / Flush door on both sides			
		Sinistra Left		Destra Right	
		Stipite su 3 lati Jamb on 3 sides	Tutta altezza All height	Stipite su 3 lati Jamb on 3 sides	Tutta altezza All height
[1]	105mm	IN-105-SX	IN-105-HSX	IN-105-DX	IN-105-HDX
[2]	125mm	IN-125-SX	IN-125-HSX	IN-125-DX	IN-125-HDX
[3]	105mm	IN-V-105-SX	IN-V-105-HSX	IN-V-105-DX	IN-V-105-HDX
	125mm	IN-V-125-SX	IN-V-125-HSX	IN-V-125-DX	IN-V-125-HDX

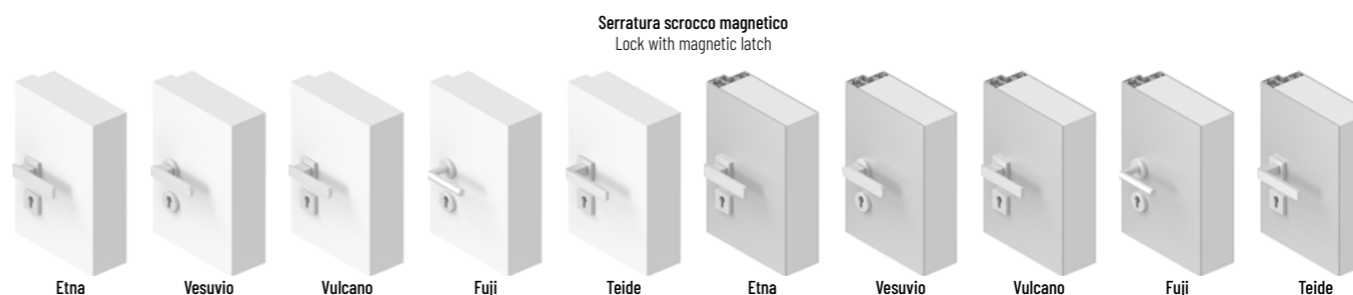

## CODICI SISTEMI DI CHIUSURA / CLOSING SYSTEMS CODES

Sistema di chiusura Closing system	Senza blocco Whitout block	Nottolino Latch free/busy	Chiave Yale Yale key
Serr. scrocco magn. per maniglia standard Lock with magnetic latch for standard handles	LV-PS1	LV-PS2	LV-PS3

## CODICI MANIGLIE / HANDLES CODES

Maniglia Handle	Senza blocco Whitout block	Nottolino Lacht free/busy	Chiave Yale Yale key
Etna	AC-350C	AC-350N	AC-350Y
Vesuvio*	AC-550C	AC-550N	AC-550Y
Vesuvio**	AC-555C	AC-555N	AC-555Y
Vulcano	AC-450C	AC-450N	AC-450Y
Fuji***	AC-120C	AC-120N	AC-120Y
Teide***	AC-220C	AC-220N	AC-120Y

\* Versione con rosetta e bocchetta quadrate / Square rosette and escutcheon version  
\*\* Versione con rosetta e bocchetta tonde / Circular rosette and escutcheon version  
\*\*\* Disponibile solo in finitura acciaio / Available only in steel finish

## 6 ACCESSORI PORTA / DOOR ACCESSORIES

Accessorio Accessory	Pagina listino Page price book
Accessori porta Door accessories	P. 141

Informazioni generali / General informations  
 Porte battenti con cornice / Hinged door and frame  
 Porte effetto filomuro / Flush-effect door  
 Porte filomuro / Flush door  
 Porte senza falso telaio / Door w/o basic door frame  
 Porte a scomparsa / Pocket door  
 Pan. scorrevoli o girevoli / Sliding or pivoting panels  
 Pan. scorrevoli o girevoli / Sliding or pivoting panels  
 Pareti divisorie / Partition wall  
 Pareti divisorie / Partition wall  
 Botserie / Boiserie  
 Botserie / Boiserie  
 Cabine armadio / Walk-in closet  
 Cabine armadio / Walk-in closet  
 Librerie / Bookcase  
 Librerie / Bookcase  
 Tavoli / Table  
 Tavoli / Table

Informazioni generali / General informations  
 Porte battenti con cornice / Hinged door and frame  
 Porte effetto filomuro / Flush-effect door  
 Porte filomuro / Flush door  
 Porte senza falso telaio / Door w/o basic door frame  
 Porte a scomparsa / Pocket door  
 Pan. scorrevoli o girevoli / Sliding or pivoting panels  
 Pan. scorrevoli o girevoli / Sliding or pivoting panels  
 Pareti divisorie / Partition wall  
 Pareti divisorie / Partition wall  
 Botserie / Boiserie  
 Botserie / Boiserie  
 Cabine armadio / Walk-in closet  
 Cabine armadio / Walk-in closet  
 Librerie / Bookcase  
 Librerie / Bookcase  
 Tavoli / Table  
 Tavoli / Table

# Filomuro cerniere esterne (38mm)

## Flush door with external hinges (38mm)

Lo stipite "filomuro cerniere esterne" permette di integrare la maggior parte delle porte del sistema prodotto Albed con la soluzione filomuro. In questo modo, è possibile installare a filomuro anche porte in alluminio e vetro con pannelli di spessore 38mm, per una estrema flessibilità progettuale. Ospita delle cerniere esterne a pivot che ne valorizzano le linee essenziali, con un'apertura a 180° dell'anta (a tirare) o a 90° (a spingere). Le cerniere esterne a pivot Albed hanno ottenuto la certificazione Catas per 100.000 cicli di apertura a 180°.

The "flush door with external hinges" jamb can be used to include most doors in the Albed product system in the flush door solution. This makes it possible to install aluminium and glass doors flush as well with 38 mm thickness panel, providing extreme design flexibility. It supports external pivot hinges which enhance its clean lines, with the door opening 180° (pull opening) or 90° (push opening). Albed's external pivot hinges are CATAS certified for 100,000 opening cycles for a 180° door.

### Porta singola / Single door



**Porta singola a tirare**  
Single pull door

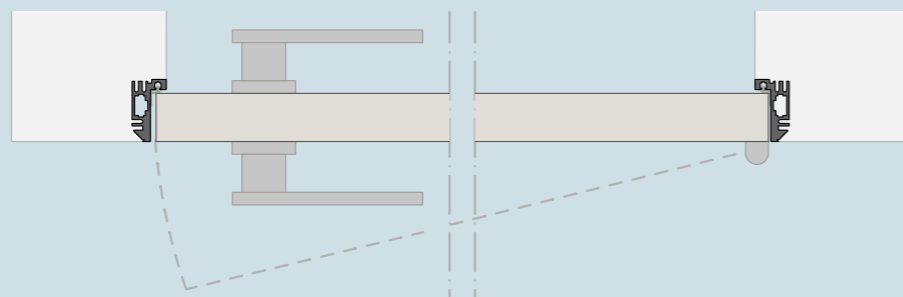

**Porta singola a spingere**  
Single push door

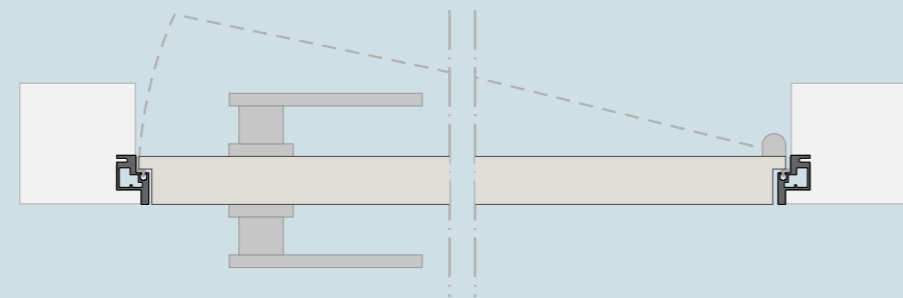

### Porta a due ante / Double door



**Porta a due ante asimmetriche a tirare**  
Asymmetrical double pull door

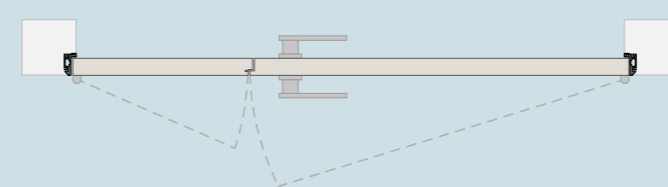

**Porta a due ante asimmetriche a spingere**  
Asymmetrical double push door

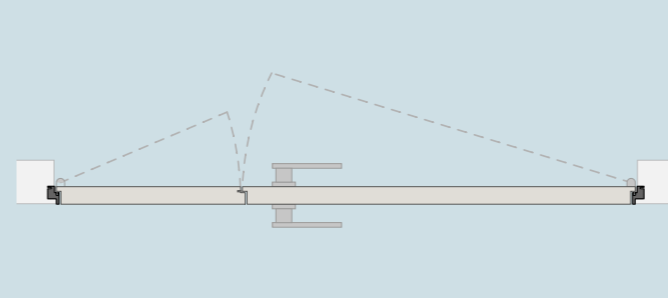

**Porta a due ante simmetriche a tirare**  
Symmetrical double pull door

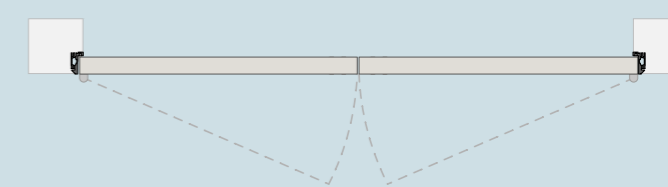

**Porta a due ante simmetriche a spingere**  
Symmetrical double push door

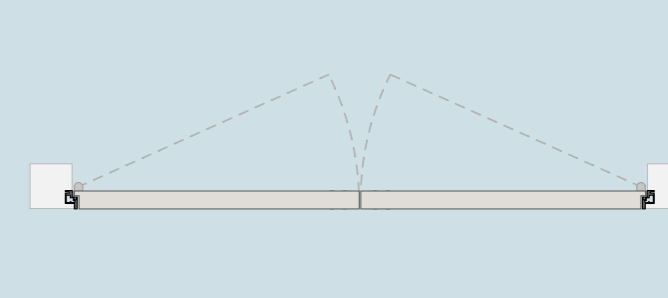

# Filomuro cerniere esterne (38mm)

## Flush door with external hinges (38mm)

### Compatibilità / Compatibilities

#### Quadra

P. 128

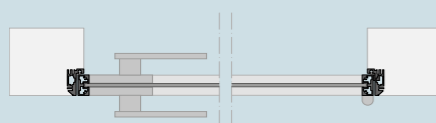

**Quadra vetro singolo a tirare**  
Quadra single glass to pull



**Quadra doppio vetro a tirare**  
Quadra double glass to pull

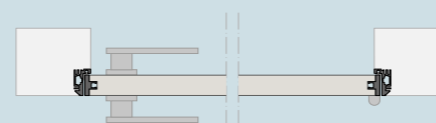

**Quadra pannello a tirare**  
Quadra panel to pull



**Quadra vetro singolo a spingere**  
Quadra single glass to push



**Quadra doppio vetro a spingere**  
Quadra double glass to push

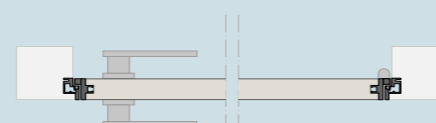

**Quadra pannello a spingere**  
Quadra panel to push

#### Celine

P. 132

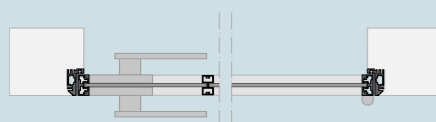

**Celine a tirare**  
Celine to pull

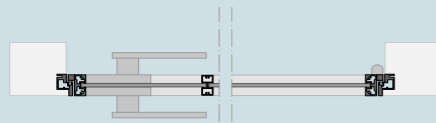

**Celine a spingere**  
Celine to push

#### Ri-trait

P. 134

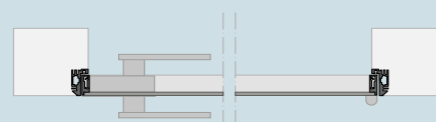

**Ri-trait vetro a tirare**  
Ri-trait glass to pull



**Ri-trait vetro a spingere**  
Ri-trait glass to push

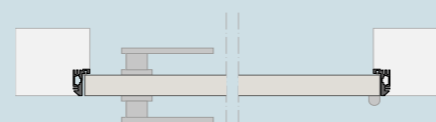

**Ri-trait pannello a tirare**  
Ri-trait panel to pull

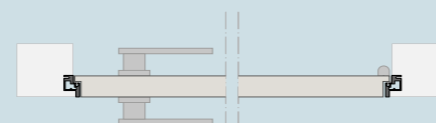

**Ri-trait pannello a spingere**  
Ri-trait panel to push

#### Ring

P. 138

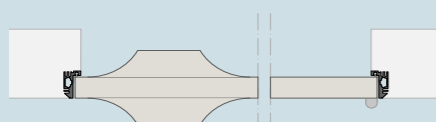

**Ring a tirare**  
Ring to pull

#### Blow

P. 139

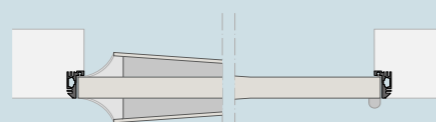

**Blow a tirare**  
Blow to pull

#### Prima

P. 130

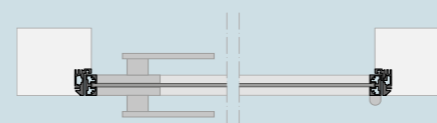

**Prima a tirare**  
Prima to pull



**Prima a spingere**  
Prima to push

#### Ri-trait 8b

P. 136

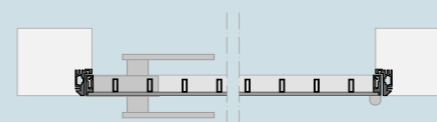

**Ri-trait 8b a tirare**  
Ri-trait 8b to pull

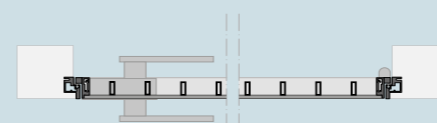

**Ri-trait 8b a spingere**  
Ri-trait 8b to push

### Dettagli / Details

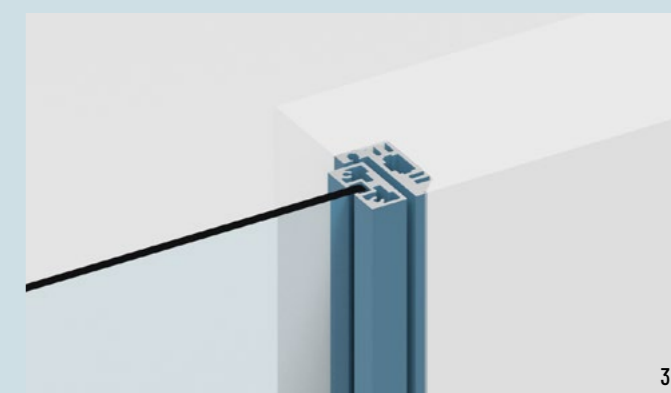
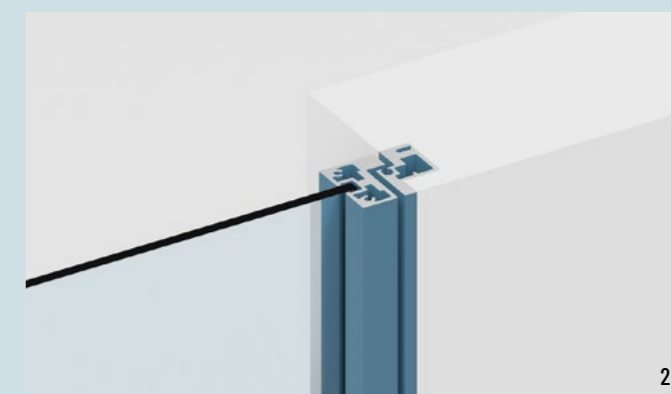
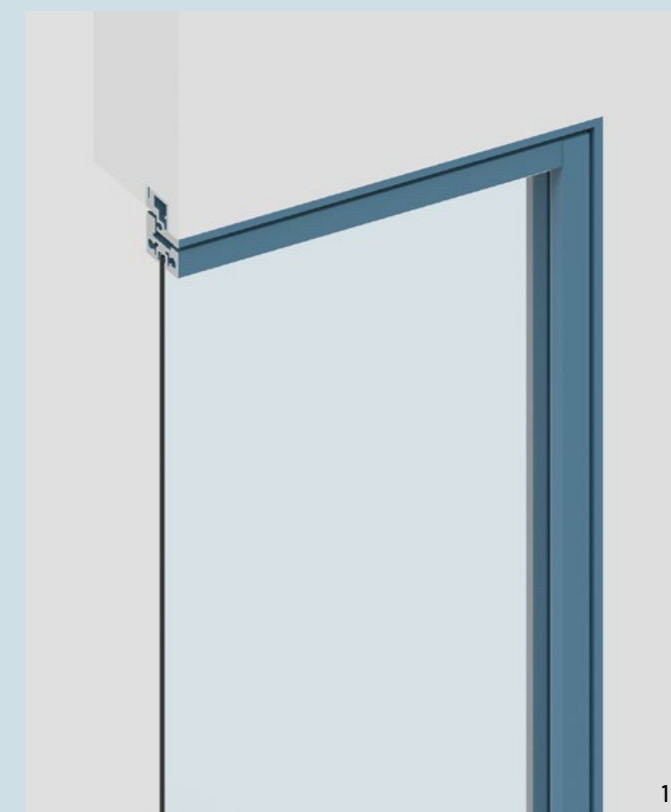

1. Sezione verticale filomuro cerniere esterne con Prima a spingere  
1. Vertical section flush door with external hinges with Prima to push

2. Sez. orizzontale filomuro cerniere esterne con Prima a spingere  
2. Horizontal section flush door with external hinges with Prima to push

3. Sez. orizzontale filomuro cerniere esterne con Prima a tirare  
3. Horizontal section flush door with external hinges with Prima

# Filomuro bilico (38mm)

## Pivoting flush door (38mm)

Lo stipite "Filomuro Bilico" connette il carattere nitido e accogliente del meccanismo a bilico con la definizione tecnica della soluzione filomuro. La porta diventa un elemento architettonico mobile, che ruota su se stessa e scompare nella parete. Il meccanismo a bilico Albed non prevede alcun intervento sul pavimento. La porta è senza battuta ma, grazie ad un sistema di serratura magnetica, si ferma automaticamente in posizione di chiusura mantenendo la planarità con la parete.

The "Pivoting Flush Door" jamb combines the neat, welcoming character of the pivoting mechanism with the technical definition of the flush door solution. The door becomes a mobile architectural element, which rotates and disappears into the wall. The Albed pivoting mechanism does not require any adaptation on the floor. The door does not have a frame but the magnetic lock system automatically stops it in the closed position, remaining flush with the wall.

### Porta singola / Single door



**Porta singola bilico**  
Pivoting single door

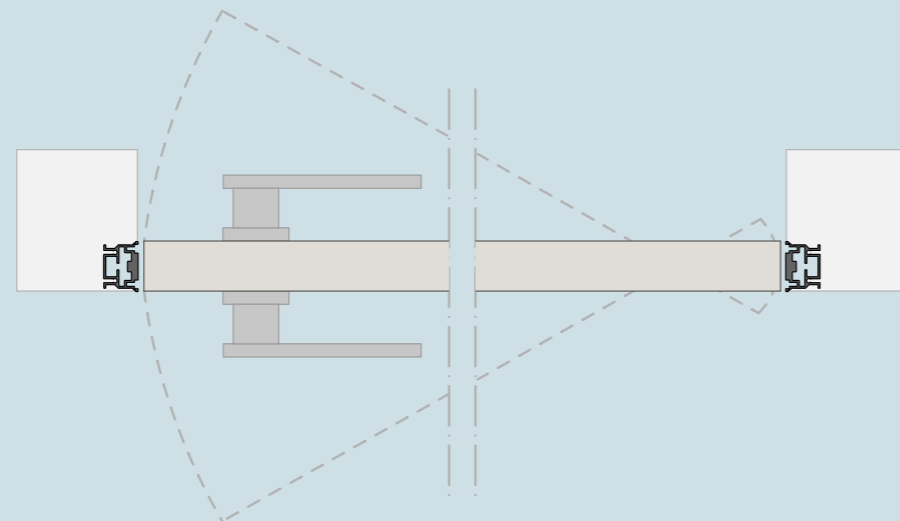

### Porta a due ante / Double door



**Porta a due ante simmetriche bilico**  
Pivoting symmetrical double door

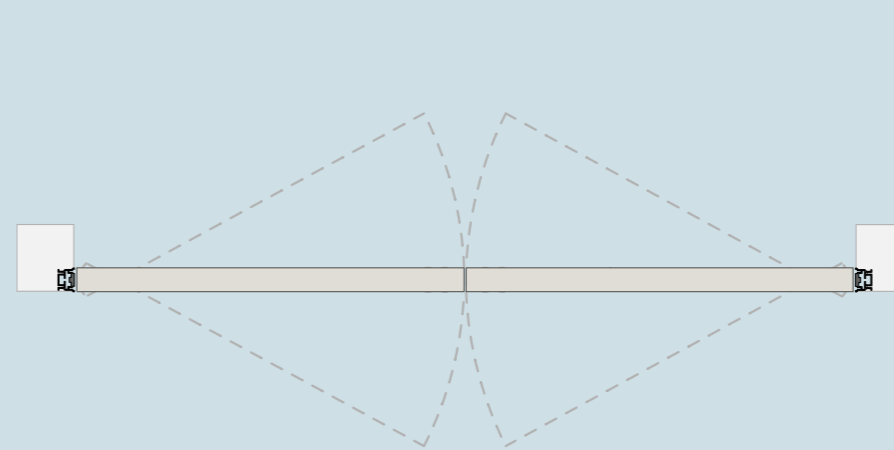

# Filomuro bilico (38mm)

## Pivoting flush door (38mm)

### Compatibilità / Compatibilities

#### Quadra

P. 128

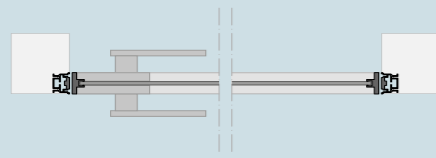

Quadra vetro singolo bilico  
Pivoting Quadra single glass

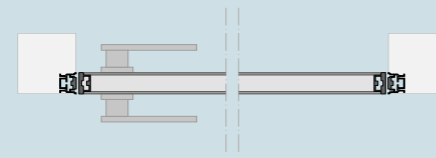

Quadra doppio vetro bilico  
Pivoting Quadra double glass

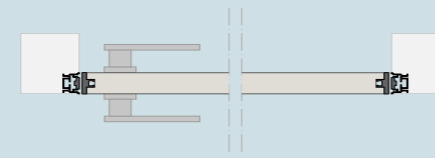

Quadra pannello bilico  
Pivoting Quadra panel

#### Prima

P. 130

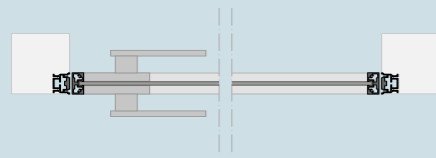

Prima bilico  
Pivoting Prima

#### Celine

P. 132

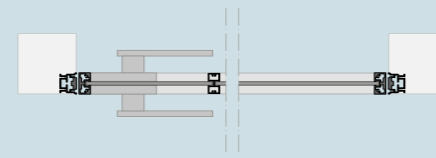

Celine bilico  
Pivoting Celine

#### Ri-trait

P. 134

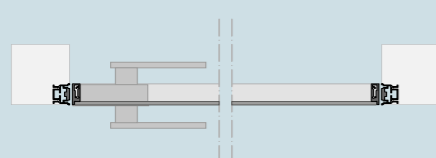

Ri-trait vetro bilico  
Pivoting Ri-trait glass

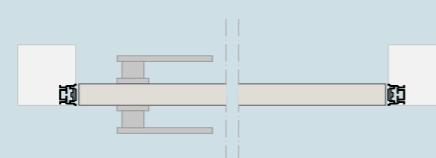

Ri-trait pannello bilico  
Pivoting Ri-trait panel

#### Ri-trait 8b

P. 136

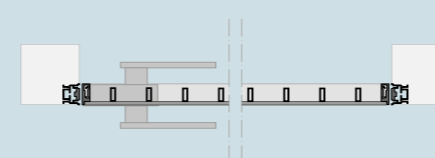

Ri-trait 8b bilico  
Pivoting Ri-trait 8b

### Dettagli / Details

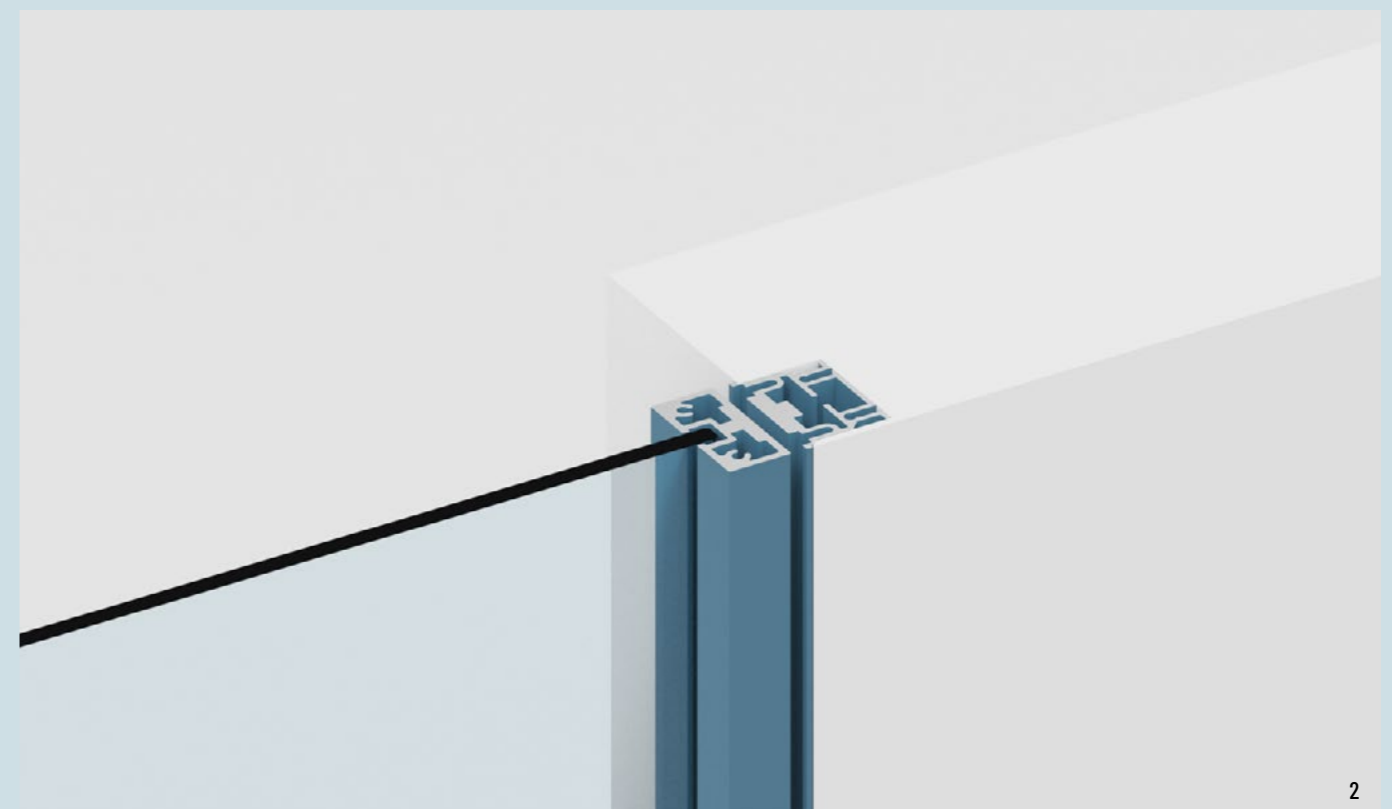
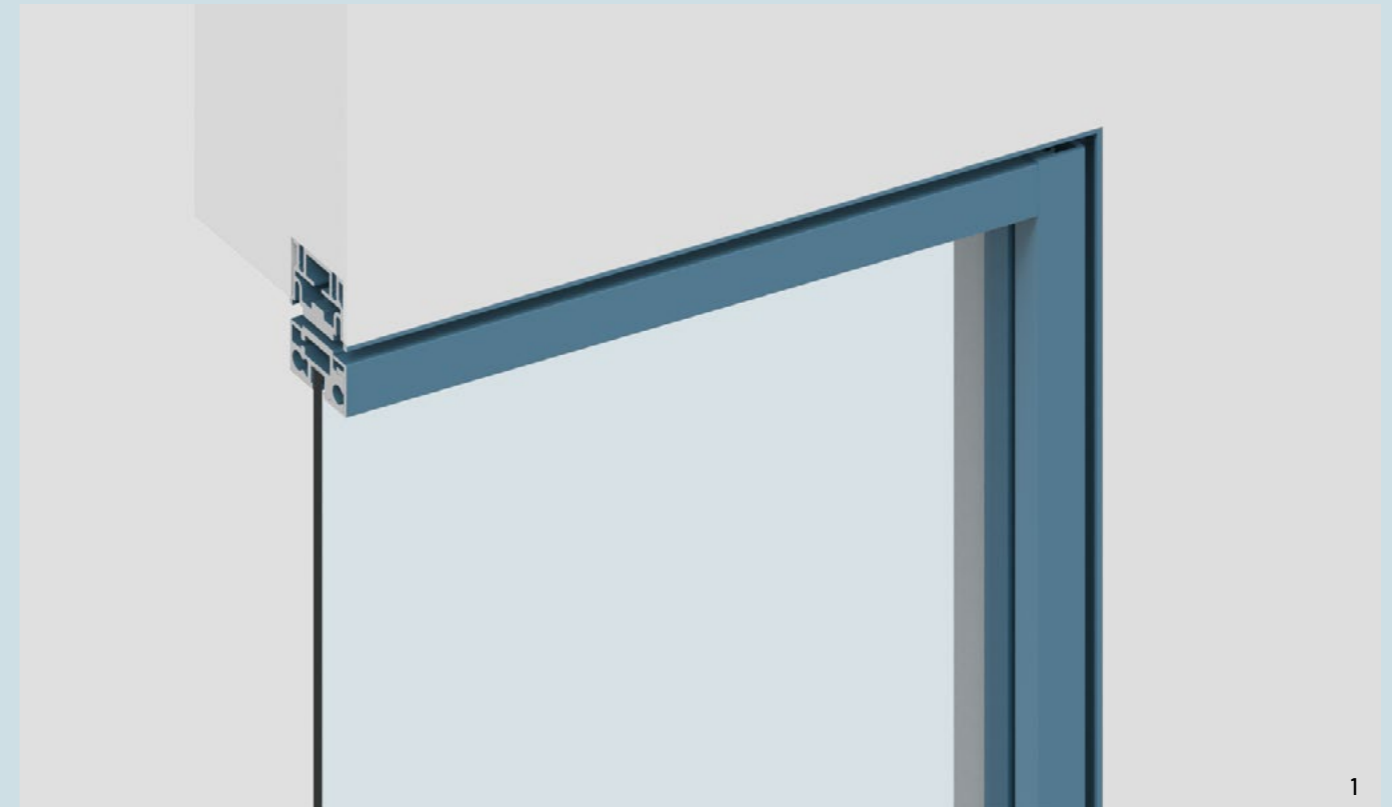

1. Sezione verticale filomuro bilico con Prima  
1. Vertical section pivoting flush door with Prima

2. Sezione orizzontale filomuro bilico con Prima  
2. Horizontal section pivoting flush door with Prima







# Celine filomuro

## Celine flush door

### 1 PORTE SINGOLE STANDARD / STANDARD SINGLE DOORS

Tipo pannello Panel type	Finiture base Base finishings	Divisioni vetro Glass divisions	Filomuro cerniere esterne Flush door with external hinges	Filomuro bilico Pivoting flush door
Vetro Glass	Vetro Cat. A / Glass Cat. A Finitura alluminio anodizzato o RAL 9003 / Anodized aluminum finishing or RAL 9003	[1] [2]	€ 1.220	€ 1.220
		[3] [4] [5] [6]	€ 1.320	€ 1.320

### 2 DIMENSIONI CUSTOM / CUSTOM SIZES

Tipo pannello Panel type	Luce passaggio: Passage clearance:	L < 1000	L < 1200*
Vetro Glass	H < 2400	+ € 75	+ € 100
	H < 2700	+ € 200	+ € 250
	H < 3000	+ € 350	+ € 450

\*disponibile solo per porte filomuro bilico  
\*available only for pivoting flush door

### 3 FINITURE / FINISHINGS

Tipo pannello Panel type	Finitura Finishing	P. 30
Vetro Glass	Vetro Cat. B / Glass Cat. B	+ 10%
	Vetro Cat. C / Glass Cat. C	+ 15%
	Vetro Cat. D / Glass Cat. D	+ 45%
	Vetro Cat. E / Glass Cat. E	+ 75%

### DIMENSIONI STANDARD / STANDARD SIZES

Porta singola Single door	Pannelli standard Standard panels	Luce passaggio Passage clearance
Cerniera est. a tirare Ext. hinge to pull	L 633/733/833 x H 2115	L 616/716/816 x H 2113
Cerniera est. a spingere Ext. hinge to pull	L 633/733/833 x H 2115	L 621/721/821 x H 2115,5
Bilico Pivoting	L 633/733/833 x H 2115	L 641/741/841 x H 2126

Al momento dell'ordine specificare il senso di apertura  
When ordering, specify the opening side of the door

Specificare 2 finiture diverse per le divisioni del vetro.  
Specify 2 different finishes for the glass divisions.

In caso di 3 o più finiture diverse sovrapprezzo + 5%  
In case of 3 or more different finishes, surcharge of + 5%

Per finiture di categorie diverse il prezzo viene  
calcolato sulla categoria più alta.  
For finishes of different categories the price is  
calculated on the highest category.

### 4 PORTE A DUE ANTE / DOUBLE DOORS

Tipo pannello Panel type	Porta a due ante Double door	
Vetro Glass	Due ante asimmetriche* Asymmetrical double door*	+ 80%
	Due ante simmetriche Symmetrical double door	+ 90%

\*non compatibile con porte filomuro bilico  
\*not compatible with pivoting flush door

Porte a due ante disponibili con luce passaggio fino a L2000  
(filomuro cerniere esterne) o fino a L2400 (filomuro bilico)  
Double doors available with passage clearance up to L2000 (single  
frame and double frame) or up to L2400 (pivoting frame)

Porta a due ante asimmetriche è formata da un pannello porta  
L833 + un pannello semifisso di L tale da riempire la luce passaggio  
Symmetrical double door is made up from a door panel L833 +  
a semi-fixed panel of Width such as to fill the passage clearance.

Porta a due ante simmetriche è formata da due pannelli  
di Larghezza uguale  
Symmetrical double door is made up of two panels of equal Width

### 5 SISTEMI DI CHIUSURA / CLOSING SYSTEMS

Tipo pannello Panel type	Sistema di chiusura Closing system	Senza blocco Whitout block	Nottolino Latch free/busy	Chiave Yale Yale key
Vetro Glass	Serratura integrata con scrocco magnetico <sup>1</sup> Integrated lock with magnetic latch <sup>1</sup>	***	***	***
	Chiusura magnetica senza scrocco <sup>2</sup> Magnetic closing without latch <sup>2</sup>	+ € 50	-	-

<sup>1</sup> non compatibile con porte filomuro bilico a due ante  
<sup>1</sup> not compatible with double pivoting flush door

<sup>2</sup> disponibile solo per Porta a due ante simmetriche.  
Per questa opzione è necessario ordinare due elementi.  
<sup>2</sup> available only for Symmetrical double door.  
For this option order two elements.

\*\*\* prezzo incluso nella maniglia  
\*\*\* price included in the handle

### 6 MANIGLIE / HANDLES

Tipo pannello Panel type	Sistema di chiusura Closing system	Maniglia Handle	Solo maniglia Only handle	Nottolino Latch free/busy	Chiave Yale Yale key
Vetro Glass	Serratura integrata con scrocco magnetico Integrated lock with magnetic latch	Etna	+ € 250	+ € 290	+ € 350
		Vesuvio	+ € 270	+ € 300	+ € 370
		Vulcano	+ € 250	+ € 290	+ € 350
	Chiusura magnetica senza scrocco Magnetic closing without latch	Volga*	+ € 100	-	-
		Adige 100mm**	+ € 100	-	-
		Adige 300mm**	+ € 200	-	-

\* Per Porta a due ante simmetriche ordinare due elementi  
\* For Symmetrical double door order two elements

\*\* Disponibile solo per porte a due ante e porte bilico  
\*\* Available only for double door and pivoting door

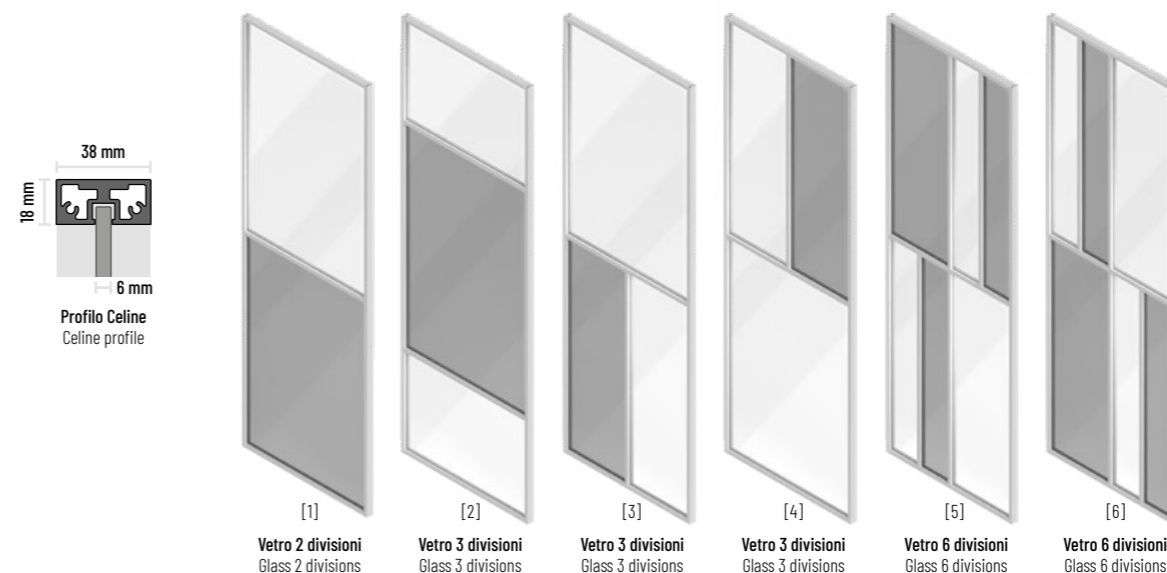

### CODICI PORTE / DOORS CODES

Tipo pannello Panel Type	Filomuro cerniere esterne / Flush door with external hinge										Filom. bilico / Piv. flush door	
	Porta singola / Single door				Porta a due ante / Double door						Porta singola sx o dx Single door left or right	Porta a due ante simme- triche Symmetrical double door
	Tirare / Pull		Spingere / Push		Tirare / Pull		Spingere / Push		Simmetrica			
Sinistra Left	Destra Right	Sinistra Left	Destra Right	Anta princ. sx Left main door	Anta princ. dx Right main door	Simmetrica Symmetrical	Anta princ. sx Left main door	Anta princ. dx Right main door	Simmetrica Symmetrical			
[1]	CL-F11S	CL-F11D	CL-F71S	CL-F71D	CERT001	CERT002	CERT003	CERT019	CERT020	CERT021	CERU001	CERU002
[2]	CL-F21S	CL-F21D	CL-F81S	CL-F81D	CERT004	CERT005	CERT006	CERT022	CERT023	CERT024	CERU003	CERU004
[3]	CL-F31S	CL-F31D	CL-F91S	CL-F91D	CERT007	CERT008	CERT009	CERT025	CERT026	CERT027	CERU005	CERU006
[4]	CL-F41S	CL-F41D	CL-F101S	CL-F101D	CERT010	CERT011	CERT012	CERT028	CERT029	CERT030	CERU007	CERU008
[5]	CL-F51S	CL-F51D	CL-F111S	CL-F111D	CERT013	CERT014	CERT015	CERT031	CERT032	CERT033	CERU009	CERU010
[6]	CL-F61S	CL-F61D	CL-F121S	CL-F121D	CERT016	CERT017	CERT018	CERT034	CERT035	CERT036	CERU011	CERU012

Serratura integrata con scrocco magnetico  
Integrated lock with magnetic latch

Chiusura magnetica senza scrocco  
Magnetic closing without latch

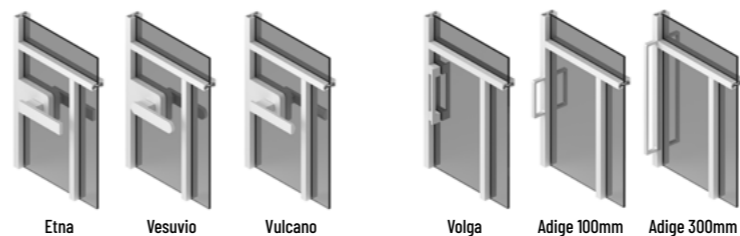

### CODICI SISTEMI DI CHIUSURA / CLOSING SYSTEMS CODES

Sistema di chiusura Closing system	Senza blocco Without block
Chiusura magnetica senza scrocco / Magnetic closing without latch	MT-100

### CODICI MANIGLIE / HANDLES CODES

Maniglia Handle	Solo maniglia Only handle	Nottolino Latch free/busy	Chiave Yale Yale key
Etna*	PR-PS10	PR-PS20	PR-PS30
Vesuvio*	PR-PS1000	PR-PS2000	PR-PS3000
Vulcano*	PR-PS100	PR-PS200	PR-PS300
Volga	B	-	-
Adige 100mm	RX	-	-
Adige 300mm	R2X	-	-

\*Maniglia con serratura integrata scrocco magn. / Maniglia with integrated lock with magnetic latch



# Ri-trait 8b filomuro

## Ri-trait 8b flush door

### 1 PORTE SINGOLE STANDARD / STANDARD SINGLE DOORS

Tipo pannello Panel type	Finitura pannello Panel finishing	Finitura stipite e telaio Jamb and frame finishing	Filomuro cerniere esterne Flush door with external hinges	Filomuro bilico Pivoting flush door
Vetro Glass	[1][2] [3][4] Vetro Cat. A Glass Cat. A	Finitura alluminio anodizzato / Anodized aluminum finishing	€ 1.750	€ 1.750

### DIMENSIONI STANDARD / STANDARD SIZES

Porta singola Single door	Pannelli standard Standard panels	Luce passaggio Passage clearance
Cerniera est. a tirare Ext. hinge to pull	L 633/733/833 x H 2115	L 616/716/816 x H 2113
Cerniera est. a spingere Ext. hinge to pull	L 633/733/833 x H 2115	L 621/721/821 x H 2115,5
Bilico Pivoting	L 633/733/833 x H 2115	L 641/741/841 x H 2126

Al momento dell'ordine specificare il senso di apertura  
When ordering, specify the opening side of the door

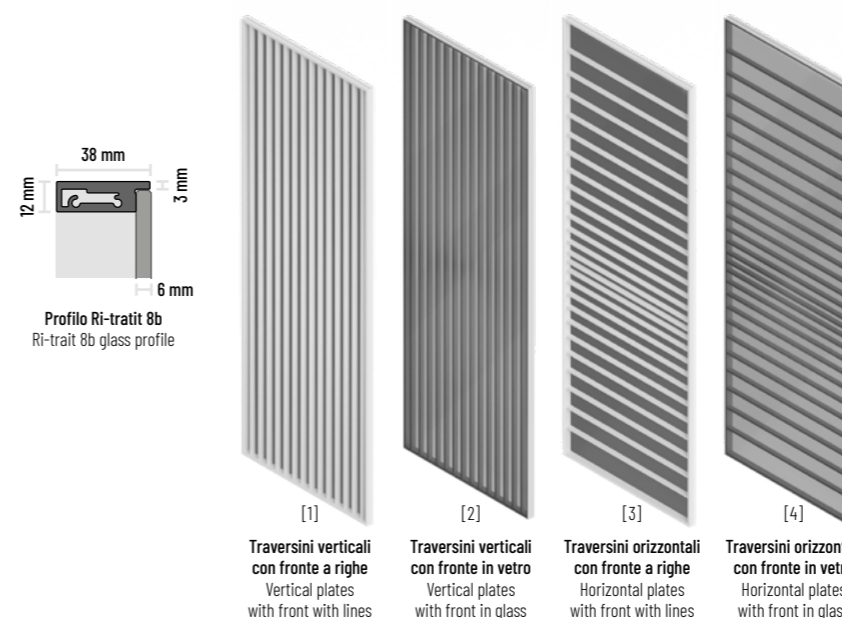

### 2 DIMENSIONI CUSTOM / CUSTOM SIZES

Tipo pannello Panel type	Luce passaggio: Passage clearance:	L < 1000	L < 1200*
Vetro Glass	H < 2400	+ € 220	+ € 300
	H < 2700	+ € 360	+ € 450
	H < 3000	+ € 550	+ € 750

\*disponibile solo per porte filomuro bilico  
\*available only for pivoting flush door

### 3 FINITURE / FINISHINGS

Tipo pannello Panel type	Finitura Finishing	P. 30
Vetro Glass	Vetro Cat. B / Glass Cat. B	+ 10%
	Vetro Cat. C / Glass Cat. C	+ 15%
	Vetro Cat. D / Glass Cat. D	+ 45%

### 4 PORTE A DUE ANTE / DOUBLE DOORS

Tipo pannello Panel type	Porta a due ante Double door	
Vetro Glass	Due ante asimmetriche* Asymmetrical double door*	+ 80%
	Due ante simmetriche Symmetrical double door	+ 90%

\*non compatibile con porte filomuro bilico  
\*not compatible with pivoting flush door

Porte a due ante disponibili con luce passaggio fino a L2000 (filomuro cerniere esterne) o fino a L2400 (filomuro bilico)  
Double doors available with passage clearance up to L2000 (single frame and double frame) or up to L2400 (pivoting frame)

Porta a due ante asimmetriche è formata da un pannello porta L833 + un pannello semifisso di L tale da riempire la luce passaggio  
Symmetrical double door is made up from a door panel L833 + a semi-fixed panel of Width such as to fill the passage clearance.

Porta a due ante simmetriche è formata da due pannelli di Larghezza uguale  
Symmetrical double door is made up of two panels of equal Width

### 5 SISTEMI DI CHIUSURA / CLOSING SYSTEMS

Tipo pannello Panel type	Sistema di chiusura Closing system	Senza blocco Whitout block	Nottolino Latch free/busy	Chiave Yale Yale key
Vetro Glass	Serratura integrata con scrocco magnetico <sup>1</sup> Integrated lock with magnetic latch <sup>1</sup>	***	***	***
	Chiusura magnetica senza scrocco <sup>2</sup> Magnetic closing without latch <sup>2</sup>	+ € 50	-	-

<sup>1</sup> non compatibile con porte filomuro bilico a due ante  
<sup>1</sup> not compatible with double pivoting flush door

<sup>2</sup> disponibile solo per Porta a due ante simmetriche.  
Per questa opzione è necessario ordinare due elementi.  
<sup>2</sup> available only for Symmetrical double door.  
For this option order two elements.

\*\*\* prezzo incluso nella maniglia  
\*\*\* price included in the handle

### 6 MANIGLIE / HANDLES

Tipo pannello Panel type	Sistema di chiusura Closing system	Maniglia Handle	Solo maniglia Only handle	Nottolino Latch free/busy	Chiave Yale Yale key
Vetro Glass	Serratura integrata con scrocco magnetico Integrated lock with magnetic latch	Etna Vesuvio Vulcano	+ € 250 + € 270 + € 250	+ € 290 + € 300 + € 290	+ € 350 + € 370 + € 350
	Chiusura magn. snz scrocco Magnetic closing without latch	Adige 200mm*	+ € 100	-	-

\* Per Porta a due ante simmetriche ordinare due elementi  
\* For Symmetrical double door order two elements

### CODICI PORTE / DOORS CODES

Tipo pannello Panel Type	Filomuro cerniere esterne / Flush door with external hinge									Filom. bilico / Piv. flush door		
	Porta singola / Single door				Porta a due ante / Double door					Porta singola sx o dx Single door left or right	Porta a due ante simme- triche Symmetrical double door	
	Tirare / Pull		Spingere/ Push		Tirare / Pull		Spingere/ Push					
Sinistra Left	Destra Right	Sinistra Left	Destra Right	Anta princ. sx Left main door	Anta princ. dx Right main door	Simmetrica Symmetrical	Anta princ. sx Left main door	Anta princ. dx Right main door	Simmetrica Symmetrical			
[1]	TR-8BV-P1RS	TR-8BV-P1RD	TR-8BV-P2RS	TR-8BV-P2RD	R8RT001	R8RT002	R8RT003	R8RT013	R8RT014	R8RT015	R8RU001	R8RU002
[2]	TR-8V-P1VS	TR-8BV-P1VD	TR-8BV-P2VS	TR-8BV-P2VD	R8RT004	R8RT005	R8RT006	R8RT016	R8RT017	R8RT018	R8RU003	R8RU004
[3]	TR-8BH-P1RS	TR-8BH-P1RD	TR-8BH-P2RS	TR-8BH-P2RD	R8RT007	R8RT008	R8RT009	R8RT019	R8RT020	R8RT021	R8RU005	R8RU006
[4]	TR-8BH-P1VS	TR-8BH-P1VD	TR-8BH-P2VS	TR-8BH-P2VD	R8RT010	R8RT011	R8RT012	R8RT022	R8RT023	R8RT024	R8RU007	R8RU008

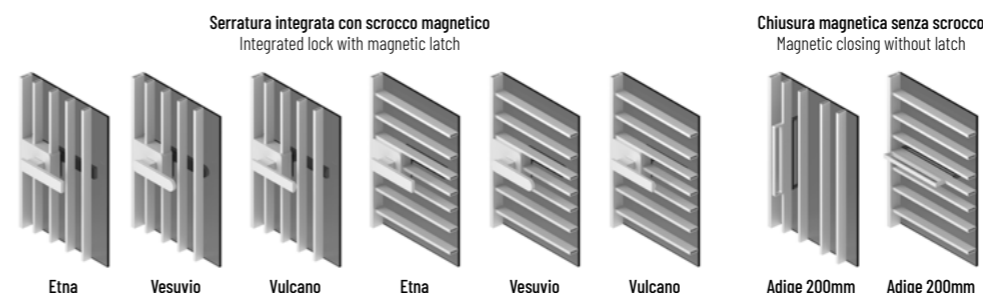

### CODICI SISTEMI DI CHIUSURA / CLOSING SYSTEMS CODES

Sistema di chiusura Closing system	Senza blocco Without block
Chiusura magnetica senza scrocco Magnetic closing without latch	MT-100

### CODICI MANIGLIE / HANDLES CODES

Maniglia Handle	Solo maniglia Only handle	Nottolino Lacht free/busy	Chiave Yale Yale key
Etna*	RT-FM1	RT-FM2	RT-FM3
Vesuvio*	RT-FM100	RT-FM200	RT-FM300
Vulcano*	RT-FM10	RT-FM20	RT-FM30
Adige 200mm	MX	-	-

\*Maniglia con serratura integrata scrocco magn. / Maniglia with integrated lock with magnetic latch

# Ring filomuro

## Ring flush door

### 1 PORTE SINGOLE STANDARD / STANDARD SINGLE DOORS

Tipo pannello Panel type	Finitura pannello Panel finishing	Finitura stipite Jamb finishing	Filomuro cerniere esterne Flush door with external hinges
<b>Pannello legno</b> Wooden panel	<b>Laccato standard opaco</b> Standard matte lacquered	<b>Finitura alluminio anodizzato</b> Anodized aluminum finishing	€ 3.300

### DIMENSIONI STANDARD / STANDARD SIZES

Porta singola Single door	Pannelli standard Standard panels	Luce passaggio Passage clearance
<b>Cerniera est. a tirare</b> Ext. hinge to pull	L 633/733/833 x H 2115	L 616/716/816 x H 2113
<b>Cerniera est. a spingere</b> Ext. hinge to pull	L 633/733/833 x H 2115	L 621/721/821 x H 2115,5

Al momento dell'ordine specificare il senso di apertura  
When ordering, specify the opening side of the door

### 2 DIMENSIONI CUSTOM / CUSTOM SIZES

Tipo pannello Panel type	Luce passaggio: Passage clearance:	L < 1000
<b>Pannello legno</b> Wooden panel	H < 2200	+ € 100

### 3 FINITURE / FINISHINGS

Tipo pannello Panel type	Finitura Finishing	P. 30
<b>Pannello legno</b> Wooden panel	<b>Laccato custom RAL opaco</b> Custom RAL matte lacquered	+ € 200
	<b>Laccato custom RAL lucido</b> Custom RAL glossy lacquered	+ € 1.000

### 4 SISTEMI DI CHIUSURA / CLOSING SYSTEMS

Tipo pannello Panel type	Sistema di chiusura Closing system	Senza blocco Whitout block	Chiave Patent Patent key	Nottolino Latch free/busy
<b>Pannello legno</b> Wooden panel	<b>Serratura integrata con scrocco magnetico</b> Integrated lock with magnetic latch	+ € 100	+ € 250	+ € 250



Pannello Ring  
Ring panel

### CODICI PORTE / DOORS CODES

Tipo pannello e sistema di chiusura Panel type and closing system	Filomuro cerniera esterna Flush door with external hinge	
	Porta singola a tirare Single door to pull	
	Sinistra / Left	Destra / Right
<b>Serratura int. senza blocco</b> / Int. lock without block	KR-RING-F1S	KR-RING-F1D
<b>Serratura int. con nottolino</b> / Int. lock with latch free/busy	KR-RING-F3S	KR-RING-F3D
<b>Serratura int. per chiave Patent</b> / Int. lock with Patent key	KR-RING-F2S	KR-RING-F2D

# Blow filomuro

## Blow flush door

### 1 PORTE SINGOLE STANDARD / STANDARD SINGLE DOORS

Tipo pannello Panel type	Finitura pannello Panel finishing	Finitura stipite Jamb finishing	Filomuro cerniere esterne Flush door with external hinges
<b>Pannello legno</b> Wooden panel	<b>Laccato standard opaco</b> Standard matte lacquered	<b>Finitura alluminio anodizzato</b> Anodized aluminum finishing	€ 3.500

### DIMENSIONI STANDARD / STANDARD SIZES

Porta singola Single door	Pannelli standard Standard panels	Luce passaggio Passage clearance
<b>Cerniera est. a tirare</b> Ext. hinge to pull	L 633/733/833 x H 2115	L 616/716/816 x H 2113
<b>Cerniera est. a spingere</b> Ext. hinge to pull	L 633/733/833 x H 2115	L 621/721/821 x H 2115,5

Al momento dell'ordine specificare il senso di apertura  
When ordering, specify the opening side of the door

### 2 DIMENSIONI CUSTOM / CUSTOM SIZES

Tipo pannello Panel type	Per luce passaggio: For passage clearance:	L < 1000
<b>Pannello legno</b> Wooden panel	H < 2200	+ € 100

### 3 FINITURE / FINISHINGS

Tipo pannello Panel type	Finitura Finishing	P. 30
<b>Pannello legno</b> Wooden panel	<b>Laccato custom RAL opaco</b> Custom RAL matte lacquered	+ € 200
	<b>Laccato custom RAL lucido</b> Custom RAL glossy lacquered	+ € 700
	<b>Rivestimento acrilico bianco</b> White acrylic coating	+ € 500
	<b>Essenza legno</b> Wooden essence	+ € 500

### 4 SISTEMI DI CHIUSURA / CLOSING SYSTEMS

Tipo pannello Panel type	Sistema di chiusura Closing system	Senza blocco Whitout block	Chiave Patent Patent key	Nottolino Latch free/busy
<b>Pannello legno</b> Wooden panel	<b>Serratura integrata con scrocco magnetico</b> Integrated lock with magnetic latch	+ € 100	+ € 250	+ € 250



Pannello Blow  
Blow panel

### CODICI PORTE / DOORS CODES

Tipo pannello e sistema di chiusura Panel type and closing system	Filomuro cerniera esterna Flush door with external hinge	
	Porta singola a tirare Single door to pull	
	Sinistra / Left	Destra / Right
<b>Serratura int. senza blocco</b> / Int. lock without block	KR-BLOW-F1S	KR-BLOW-F1D
<b>Serratura int. con nottolino</b> / Int. lock with latch free/busy	KR-BLOW-F3S	KR-BLOW-F3D
<b>Serratura int. per chiave Patent</b> / Int. lock with Patent key	KR-BLOW-F2S	KR-BLOW-F2D

# Accessori per porte filomuro

## Accessories for flush doors

### SISTEMA DI ACCESSORI ALBED PER PORTE FILOMURO / ALBED ACCESSORY SYSTEM FOR FLUSH DOORS

Accessori Accessories	Next 50mm			Next 58mm		Suit	Integra	Codice Code
	Pannello legno Wooden panel	Doppio vetro Double door	Pannello cuoio Leather panel	Pannello legno Wooden panel	Pannello E130 E130 panel	Telaio alluminio Aluminium frame	Tutti i pannelli All panels	
<b>Chiudiporta a slitta esterno</b> External rail closer	+ € 300	-	-	+ € 300	+ € 300	+ € 300	-	MT-82
<b>Chiudiporta integrato<sup>1</sup></b> Integrated closer <sup>1</sup>	+ € 480	-	-	+ € 480	***	+ € 480	+ € 480	MT-84
<b>Paraspifferi<sup>2</sup></b> Drafts preventer <sup>2</sup>	+ € 110	-	-	+ € 110	+ € 110	+ € 110	+ € 110	MT-86
<b>Incontro elettrico per serrature Sicurezza e Opera</b> Electric strike for Sicurezza and Opera locks	+ € 300	+ € 300	+ € 300	+ € 300	+ € 300	-	-	MT-90
<b>Incontro elettrico per serratura con scrocco magnetico</b> Electric strike for lock with magnetic latch	+ € 360	+ € 360	+ € 360	+ € 360	-	+ € 360	+ € 360	MT-190
<b>Maniglione antipanico</b> Panic bar	+ € 550	-	-	+ € 550	+ € 550	-	+ € 550	MT-195
<b>Maniglia a scomparsa senza blocco (B NO-HA)<sup>3</sup></b> Invisible handle without block <sup>3</sup>	+ € 200	-	-	+ € 200	-	+ € 200	-	-
<b>Maniglia a scomparsa con nottolino (B NO-HA)<sup>3</sup></b> Invisible handle with latch <sup>3</sup>	+ € 250	-	-	+ € 250	-	+ € 250	-	-
<b>Pannello appesantito</b> Weighted panel	+ € 150	-	-	+ € 150	-	-	-	-
<b>Ribassamento pannello su un lato<sup>4</sup></b> Panel lowering on one side <sup>4</sup>	+ € 90	-	-	+ € 90	-	-	-	-
<b>Ribassamento pannello su due lati</b> Panel lowering on two sides	+ € 180	-	-	+ € 180	-	-	-	-
<b>Pannello rialzato da terra (max 50mm)</b> Raised panel off the ground (max 50mm)	+ € 60	+ € 60	+ € 60	+ € 60	-	-	-	-
<b>Coppia di tiranti raddrizzanti</b> Pair of straightening rods	+ € 130	-	-	+ € 130	-	-	-	-

<sup>1</sup> Non compatibile con porte tutta altezza

<sup>1</sup> Not compatible with all height doors

<sup>2</sup> per porte con solo stipiti verticali possibilità di paraspifferi su due lati (pavimento e soffitto)

<sup>2</sup> for doors with only vertical jambs, possibility of draft preventers on two sides (floor and ceiling)

<sup>3</sup> disponibile solo con finiture "laccato standard", "laccato custom RAL" o "essenza legno"

<sup>3</sup> available only for finishing "standard lacquered", "custom RAL lacquered" or "wooden essence"

<sup>4</sup> al momento dell'ordine specificare il lato di ribassamento del pannello (fronte o retro)

<sup>4</sup> When ordering, specify the panel lowering side (front or back)

\*\*\* accessorio incluso nella porta

\*\*\* accessory included in the door



# PORTE SENZA FALSO TELAIO

## DOOR WITHOUT BASIC DOOR FRAME

La porta "senza falso telaio" è la soluzione perfetta per porte a battente quando non possono essere eseguiti lavori di predisposizione architettonica. Il telaio viene sovrapposto direttamente alle pareti, coprendo il foro architettonico senza alcuna predisposizione.

The "without basic door frame" door is ideal for hinged doors when architectural preparatory works cannot be done. The frame is fixed to the walls themselves, covering the architectural opening without any preparation.

### Sistema prodotto / Product system

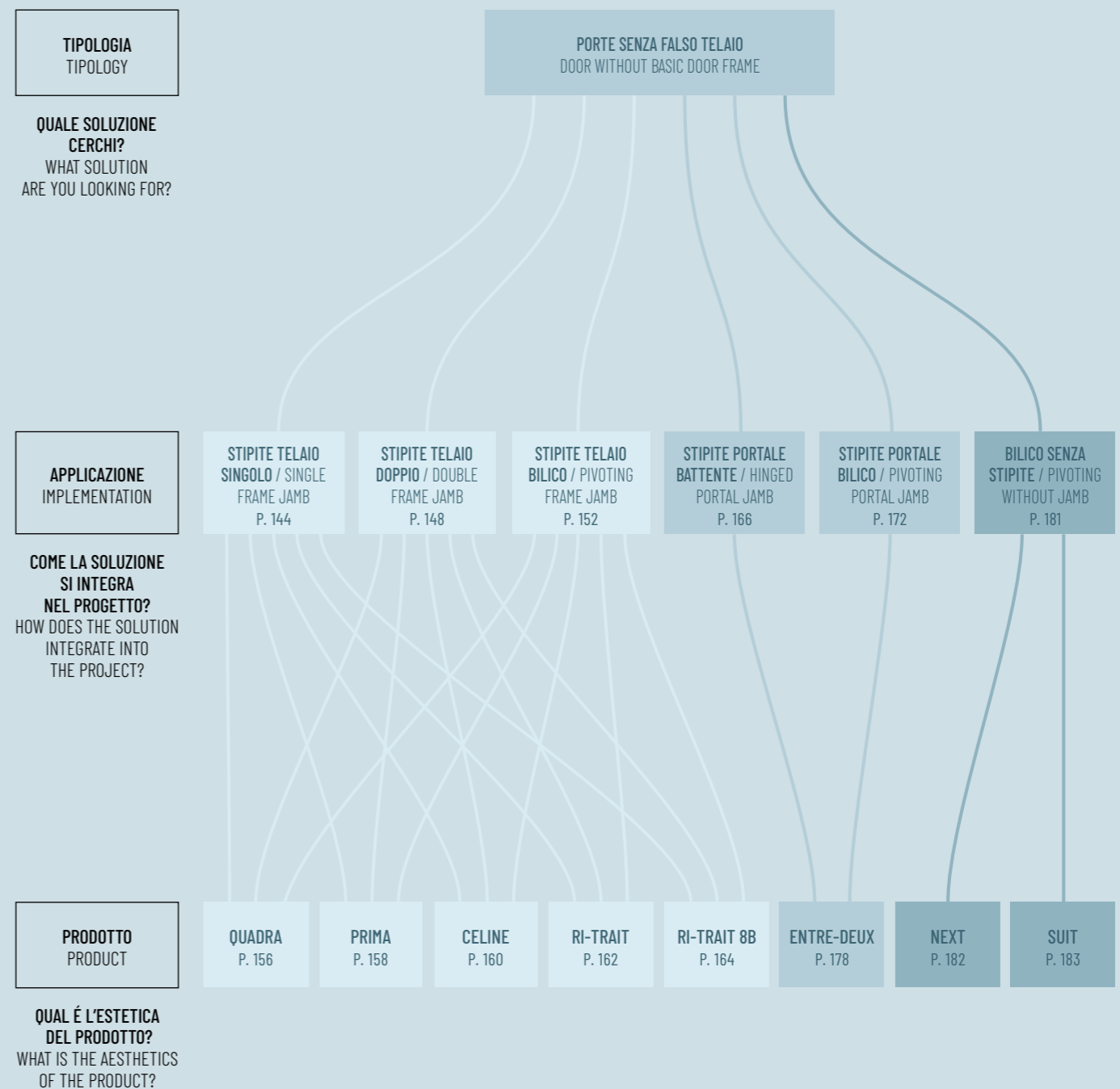



# Stipite telaio singolo

## Single frame jamb

Il sistema "Stipite telaio singolo" o "corridoio" è un sistema compatto senza falso telaio derivato dai sistemi delle pareti divisorie che permette di installare una porta in un vano a misura finito. È particolarmente efficace per l'integrazione con l'arredo o in situazioni in cui le possibilità di intervento interno sono limitate. Dotato di cerniere esterne a pivot che ne valorizzano le linee essenziali, con un'apertura a 180° dell'anta (a tirare) o a 90° (a spingere). Le cerniere esterne a pivot Albed hanno ottenuto la certificazione Catas per 100.000 cicli di apertura dell'anta a 180°.

The "Single frame jamb" system (also known as "Corridor") is a compact system, without a door frame, based on the partition wall system, which makes it possible to install a door in a finished opening of the correct size. It is particularly effective for blending with the furnishings, or when there are limited possibilities for internal work. It is fitted with external pivot hinges which enhance its clean lines, with the door opening 180° (pull opening) or 90° (push opening). Albed's external pivot hinges are CATAS certified for 100,000 opening cycles for a 180° door.

### Porta singola / Single door



### Porta a due ante / Double door

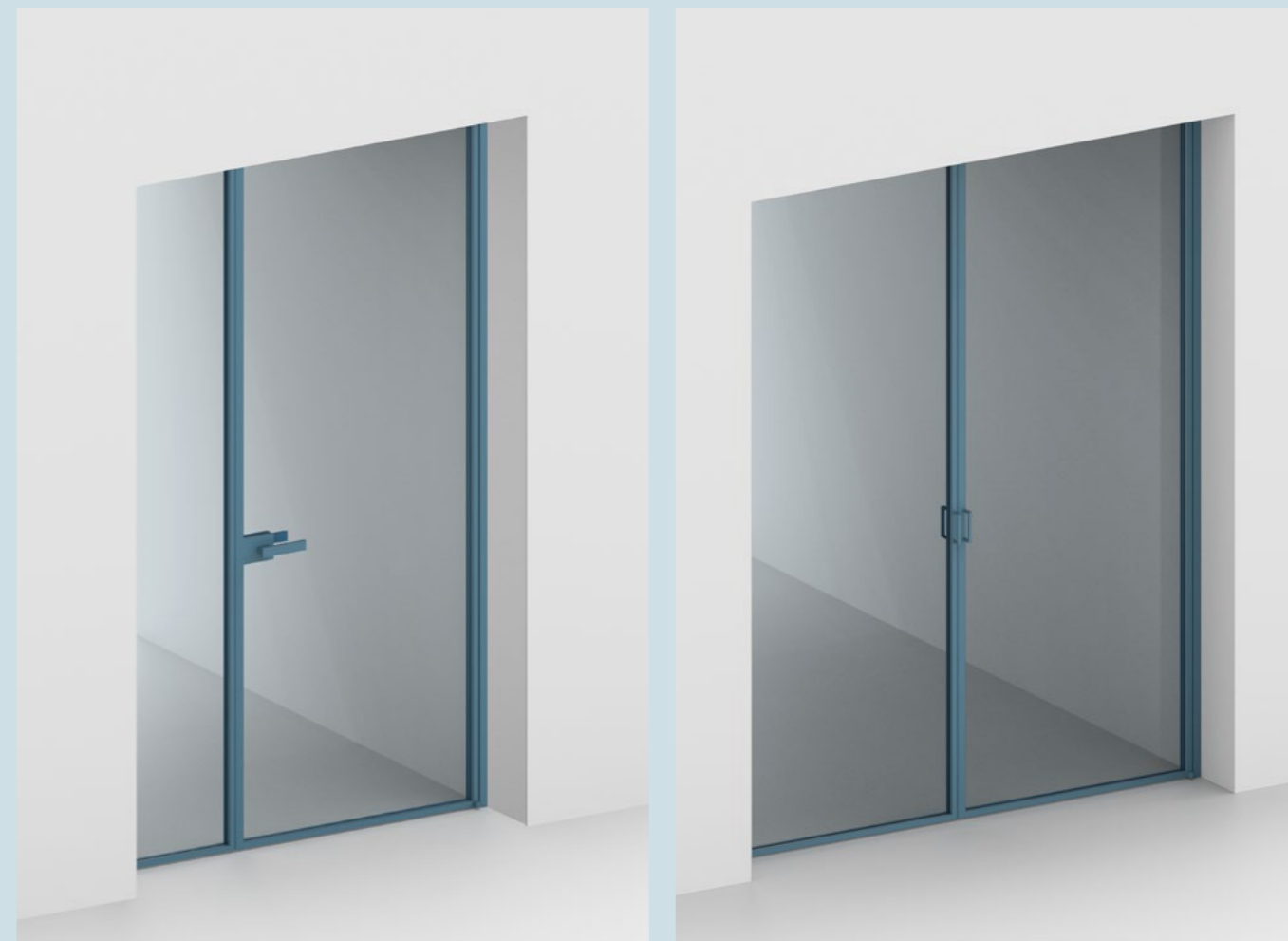

#### Porta singola a tirare Single pull door

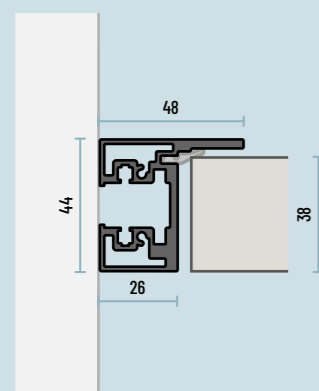

Dimensioni (mm) stipite telaio singolo  
Dimensions (mm) single frame jamb

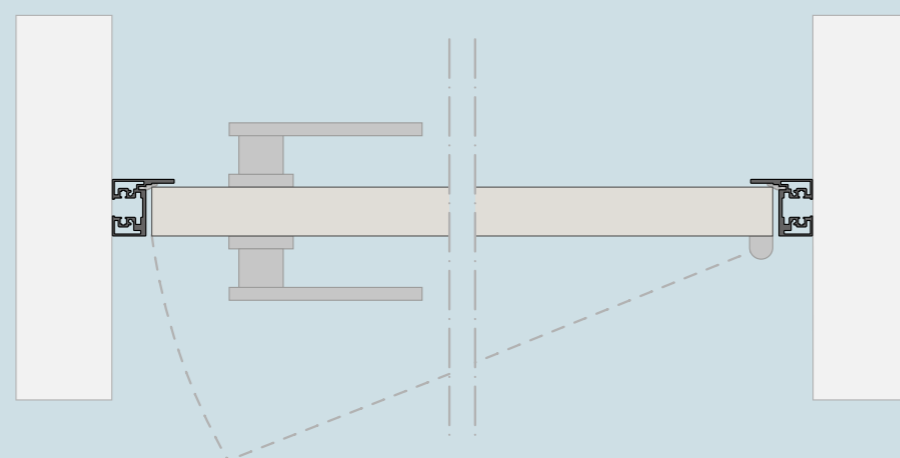

#### Porta a due ante asimmetriche a tirare Asymmetrical double pull door

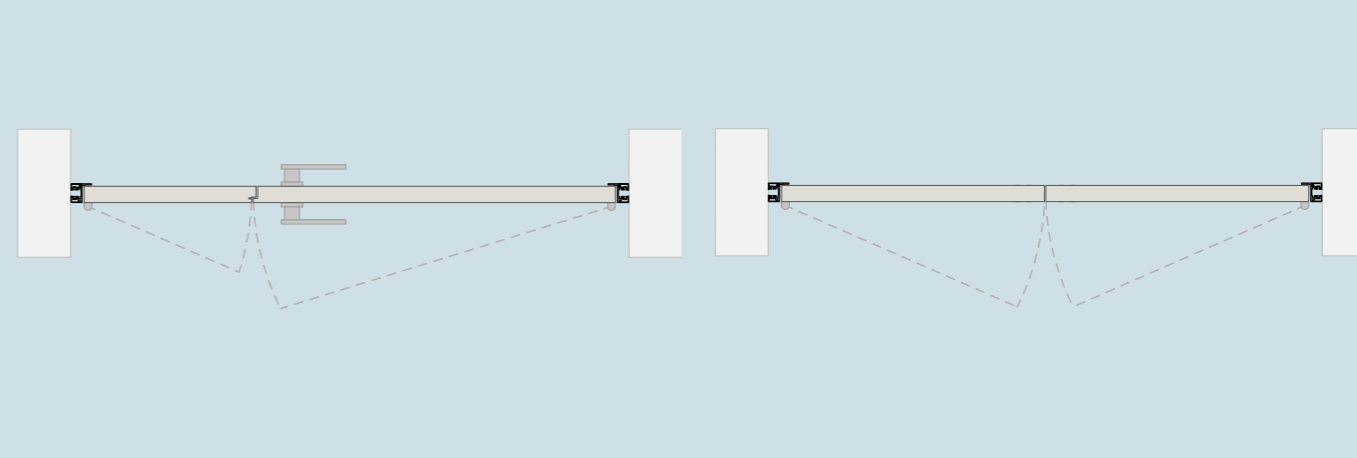

#### Porta a due ante simmetriche a tirare Symmetrical double pull door

# Stipite telaio singolo

## Single frame jamb

### Compatibilità / Compatibilities

#### Quadra

P. 156

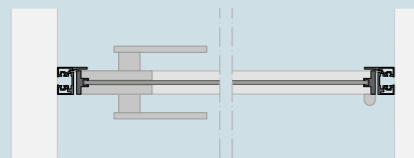

Quadra vetro singolo a tirare all'interno del foro architettonico / Quadra single glass to pull into architectural hole

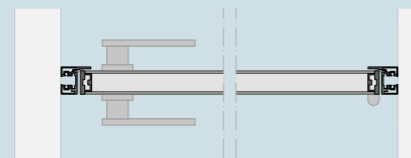

Quadra doppio vetro a tirare all'interno del foro architettonico / Quadra double glass to pull into architectural hole

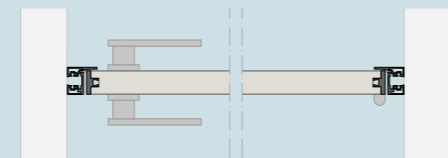

Quadra pannello a tirare all'interno del foro architettonico / Quadra panel glass to pull into architectural hole

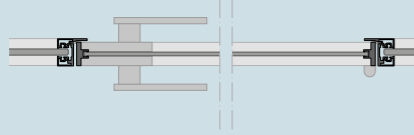

Quadra vetro singolo a tirare all'interno del sistema All Ways / Quadra single glass to pull into All Ways system

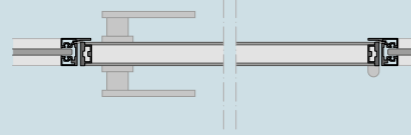

Quadra doppio vetro a tirare all'interno del sistema All Ways / Quadra double glass to pull into All Ways system

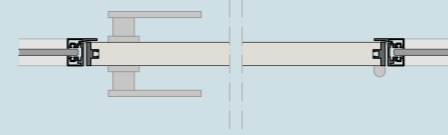

Quadra pannello a tirare all'interno del sistema All Ways / Quadra panel to pull into All Ways system

#### Prima

P. 162

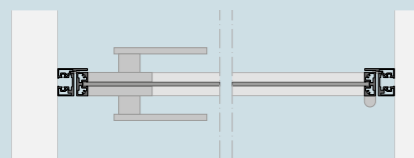

Prima a tirare all'interno del foro architettonico / Prima to pull into architectural hole

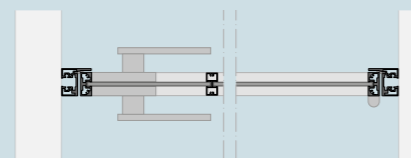

Celine a tirare all'interno del foro architettonico / Celine to pull into architectural hole

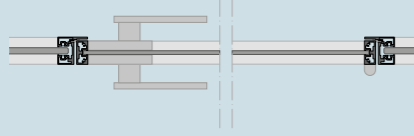

Prima a tirare all'interno del sistema All Ways / Prima to pull into All Ways system

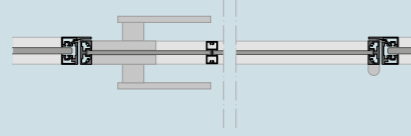

Celine a tirare all'interno del sistema All Ways / Celine to pull into All Ways system

#### Ri-trait

P. 164

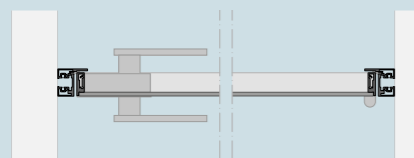

Ri-trait vetro a tirare all'interno del foro architettonico / Ri-trait glass to pull into architectural hole

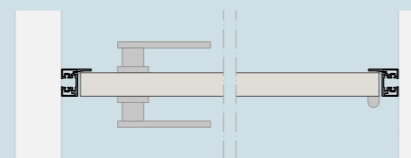

Ri-trait pannello a tirare all'interno del foro architettonico / Ri-trait panel to pull into architectural hole

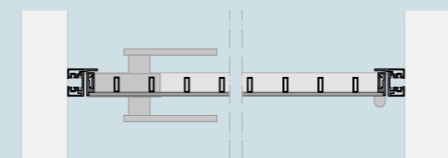

Ri-trait 8b a tirare all'interno del foro architettonico / Ri-trait 8b to pull into architectural hole

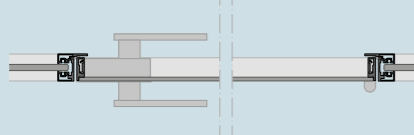

Ri-trait vetro a tirare all'interno del sistema All Ways / Ri-trait glass to pull into All Ways system

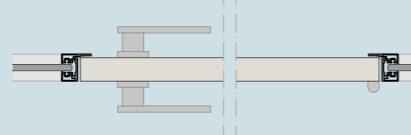

Ri-trait pannello a tirare all'interno del sistema All Ways / Ri-trait panel to pull into All Ways system

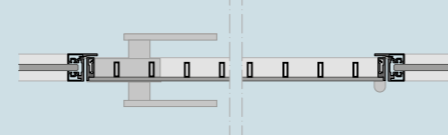

Ri-trait 8b a tirare all'interno del sistema All Ways / Ri-trait 8b to pull into All Ways system

### Dettagli / Details



1

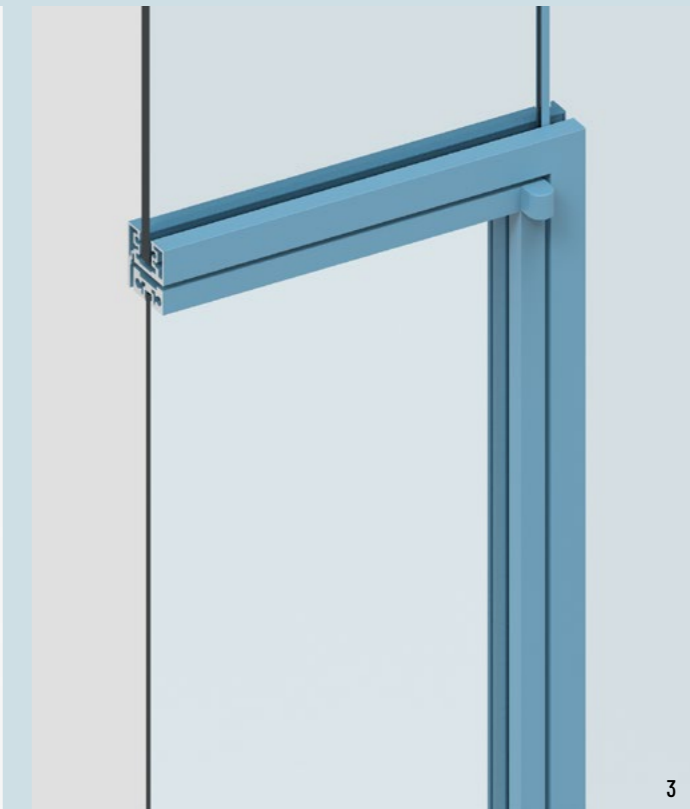

3

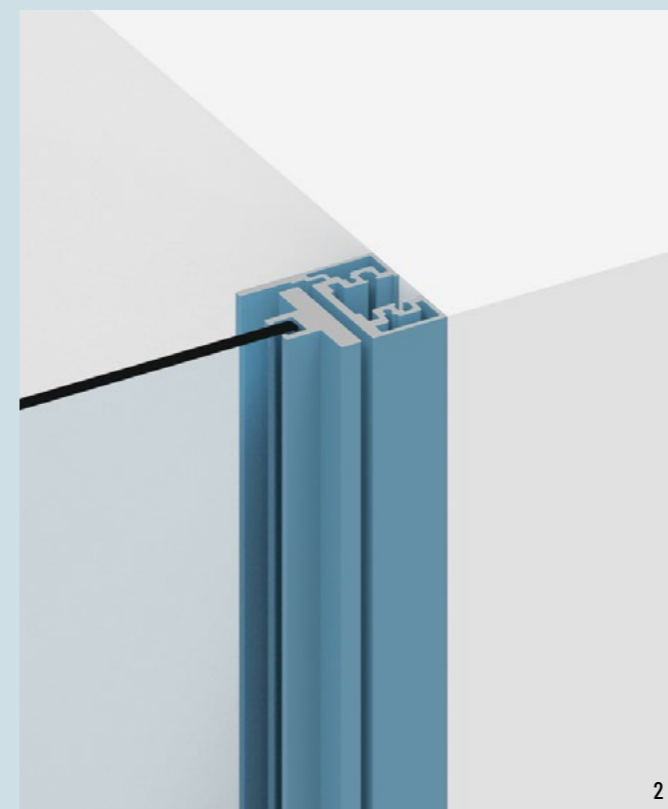

2

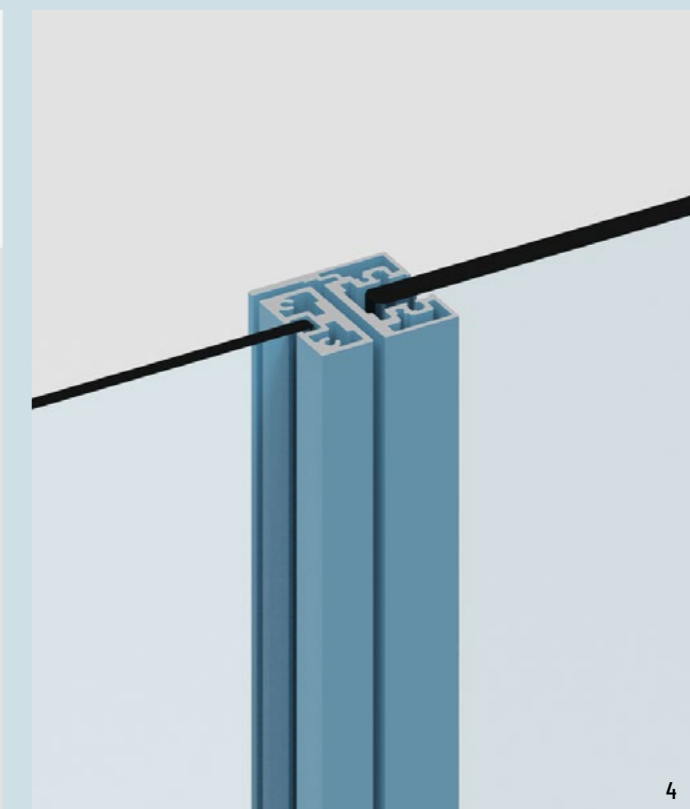

4

1. Sezione verticale Stipite telaio singolo con Quadra a tirare  
1. Vertical section Single frame jamb with Quadra to pull

2. Sezione orizzontale Stipite telaio singolo con Quadra a tirare  
2. Horizontal section Single frame jamb with Quadra to pull

3. Sezione verticale Stipite telaio singolo con Prima a tirare con sistema All Ways  
3. Vertical section Single frame jamb with Prima to pull with All Ways system

4. Sezione orizzontale Stipite telaio singolo con Prima a tirare con sistema All Ways  
4. Horizontal section Single frame jamb with Prima to pull with All Ways system

Tavoli / Table  
 Librerie / Bookcase  
 Cabine armadio / Walk-in closet  
 Boiserie / Boiserie  
 Pareti divisorie / Partition wall  
 Pan. scorrevoli o girevoli / Sliding or pivoting panels  
 Porte a scomparsa / Pocket door  
 Porte senza falso telaio / Door w/o basic door frame  
 Porte filomuro / Flush door  
 Porte battenti con cornice / Hinged door and frame  
 Informazioni generali / General informations

Tavoli / Table  
 Librerie / Bookcase  
 Cabine armadio / Walk-in closet  
 Boiserie / Boiserie  
 Pareti divisorie / Partition wall  
 Pan. scorrevoli o girevoli / Sliding or pivoting panels  
 Porte a scomparsa / Pocket door  
 Porte senza falso telaio / Door w/o basic door frame  
 Porte filomuro / Flush door  
 Porte battenti con cornice / Hinged door and frame  
 Informazioni generali / General informations

# Stipite telaio doppio

## Double frame jamb

La semplicità di installazione con il massimo dettaglio architettonico si integrano nello "Stipite Telaio Doppio", che unisce i pregi del sistema compatto "Telaio singolo" installabile direttamente a parete senza alcuna preparazione, con un controtelaio di supporto. La porta è così contenuta da un telaio sottilissimo disgiunto dalla parete con uno scuretto costante su tutto lo sviluppo, pur mantenendo la completa regolazione.

Installation simplicity and the utmost architectural detailing come together in the "Doble Frame" jamb, which combines the advantages of the compact "Single Frame" system that can be installed in the wall itself without any preparation, with a supporting counterframe. This means that the door is contained within a very slim frame, detached from the wall by an even shadow line over its entire length, while remaining fully adjustable.

### Porta singola / Single door



### Porta a due ante / Double door



#### Porta singola a tirare Single pull door

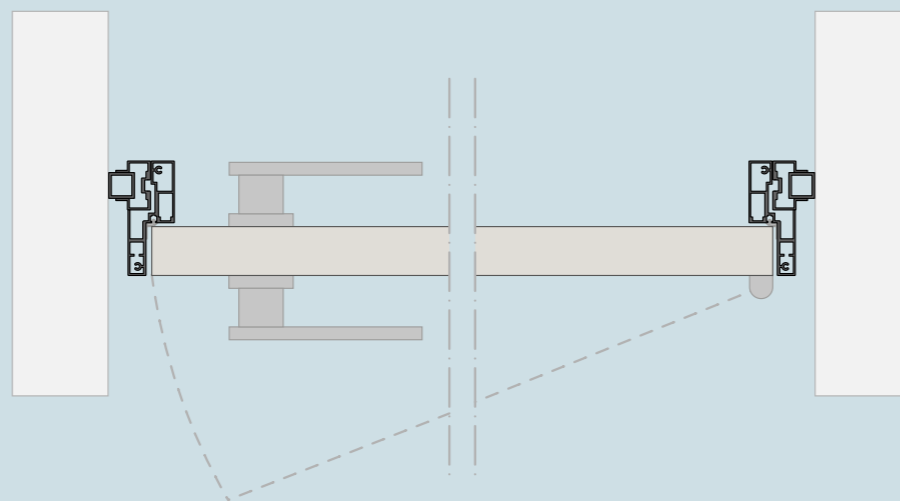

#### Porta a due ante asimmetriche a tirare Asymmetrical double pull door

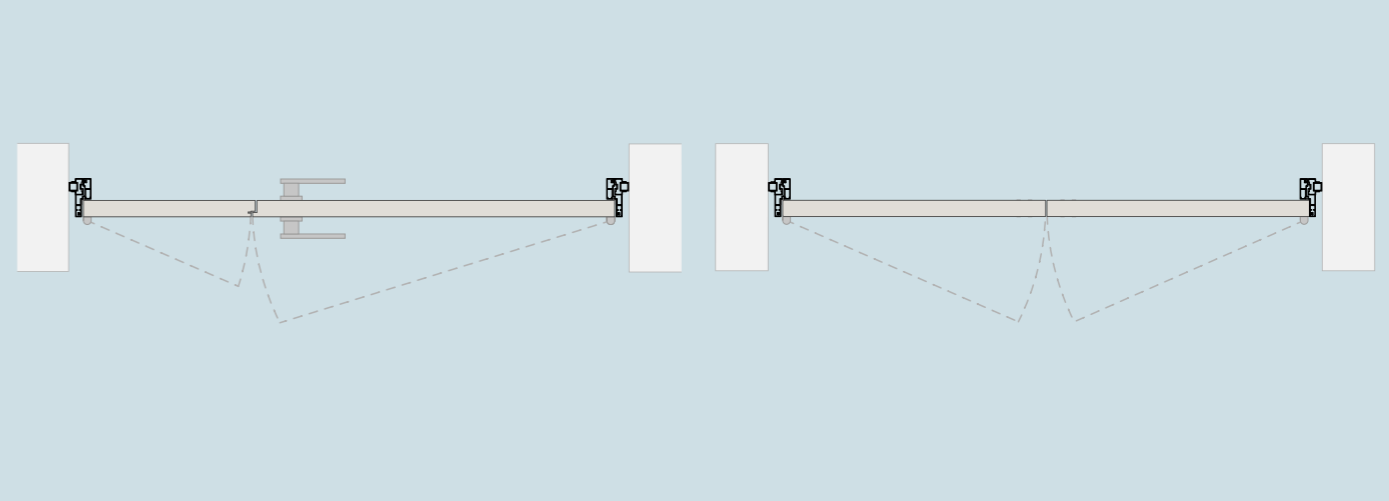

#### Porta a due ante simmetriche a tirare Symmetrical double pull door

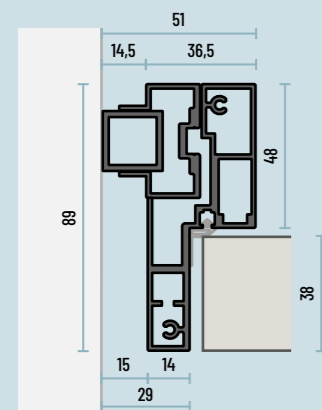

Dimensioni (mm) stipite telaio doppio  
Dimensions (mm) double frame jamb

# Stipite telaio doppio

## Double frame jamb

### Compatibilità / Compatibilities

#### Quadra

P. 156

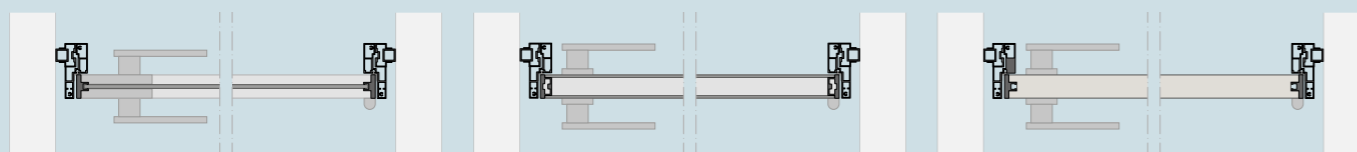

Quadra vetro singolo a tirare  
Quadra single glass to pull

Quadra doppio vetro a tirare  
Quadra double glass to pull

Quadra pannello a tirare  
Quadra panel to pull

#### Prima

P. 158

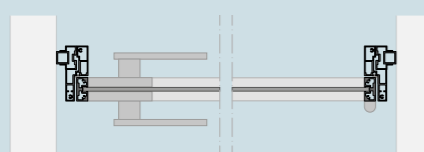

Prima a tirare  
Prima to pull

#### Celine

P. 160

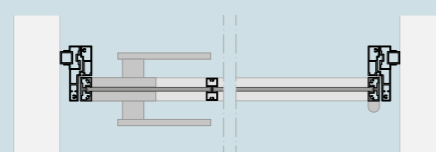

Celine a tirare  
Celine to pull

#### Ri-trait

P. 162

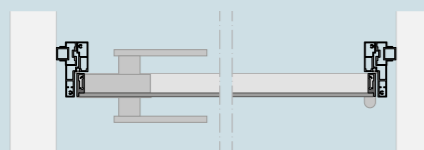

Ri-trait vetro a tirare  
Ri-trait glass to pull

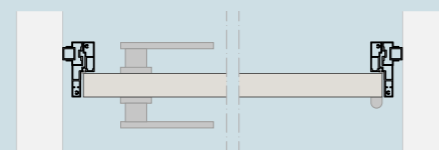

Ri-trait pannello a tirare  
Ri-trait panel to pull

#### Ri-trait 8b

P. 164

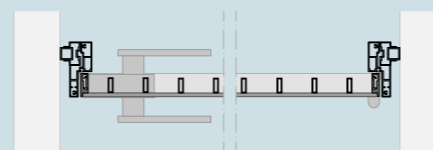

Ri-trait 8b a tirare  
Ri-trait 8b to pull

### Dettagli / Details

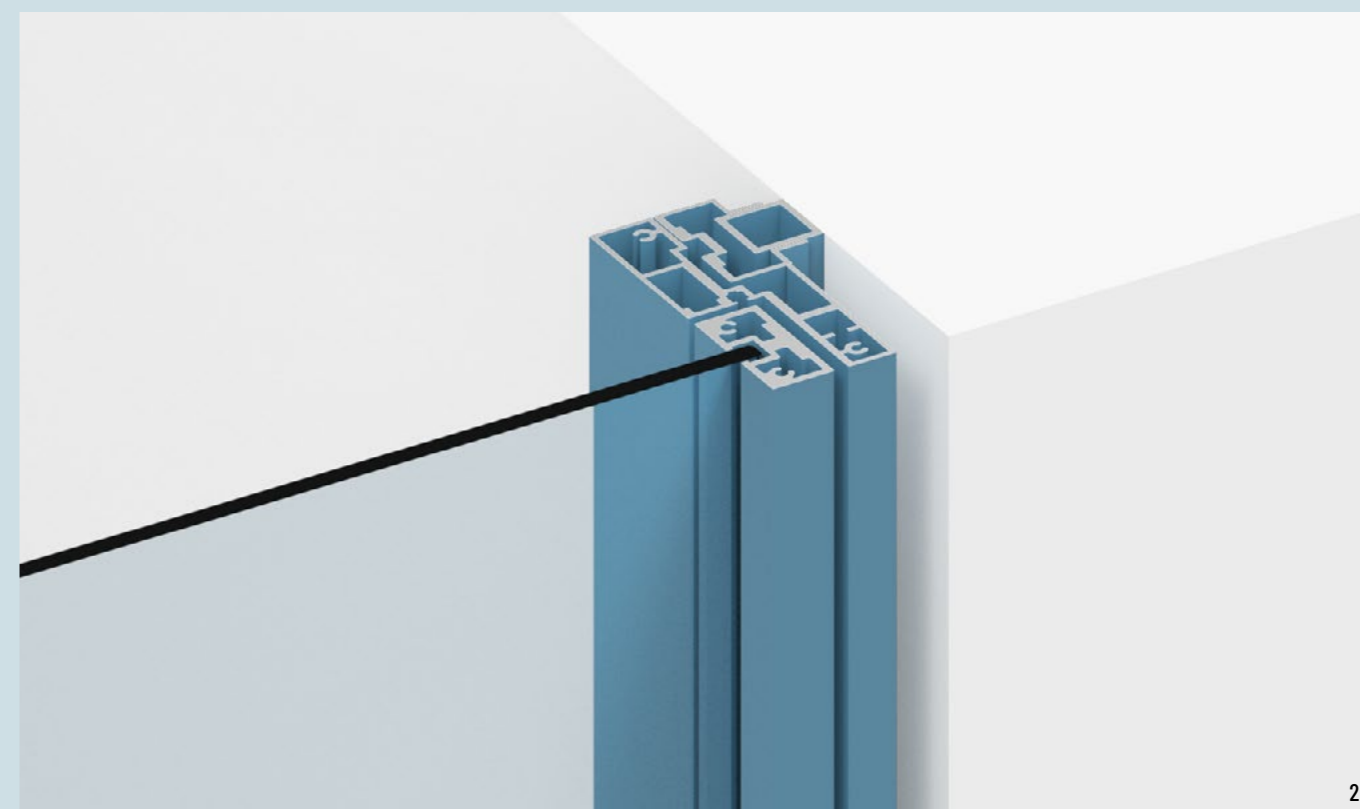

1. Sezione verticale Stipite telaio doppio con Prima a tirare  
1. Vertical section Double frame jamb with Prima to pull

2. Sezione orizzontale Stipite telaio doppio con Prima a tirare  
2. Horizontal section Double frame jamb with Prima to pull

# Stipite telaio bilico

## Pivoting frame jamb

Lo stipite "Telaio bilico" permette l'installazione di un pannello pivotante anche in vani senza predisposizione e senza interventi a pavimento. Questo stipite permette di inserire un pannello porta, anche in alluminio e vetro, in un vano architettonico o in integrazione con l'arredo, senza l'uso di falsi telai.

The "Frame for pivot" jamb makes it possible to install a pivoting panel in openings, without preparing the opening and without intervening on the floor. This jamb can be used to install a door panel, which can also be in aluminium and glass, in an architectural opening, or to match it with the furnishings, without using counterframes.

### Porta singola / Single door



**Porta singola**  
Pivoting single door

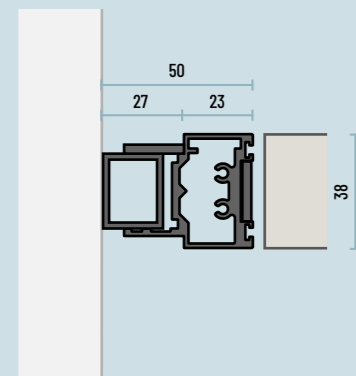

Dimensioni (mm) stipite telaio bilico  
Dimensions (mm) pivoting frame jamb

### Porta a due ante / Double door

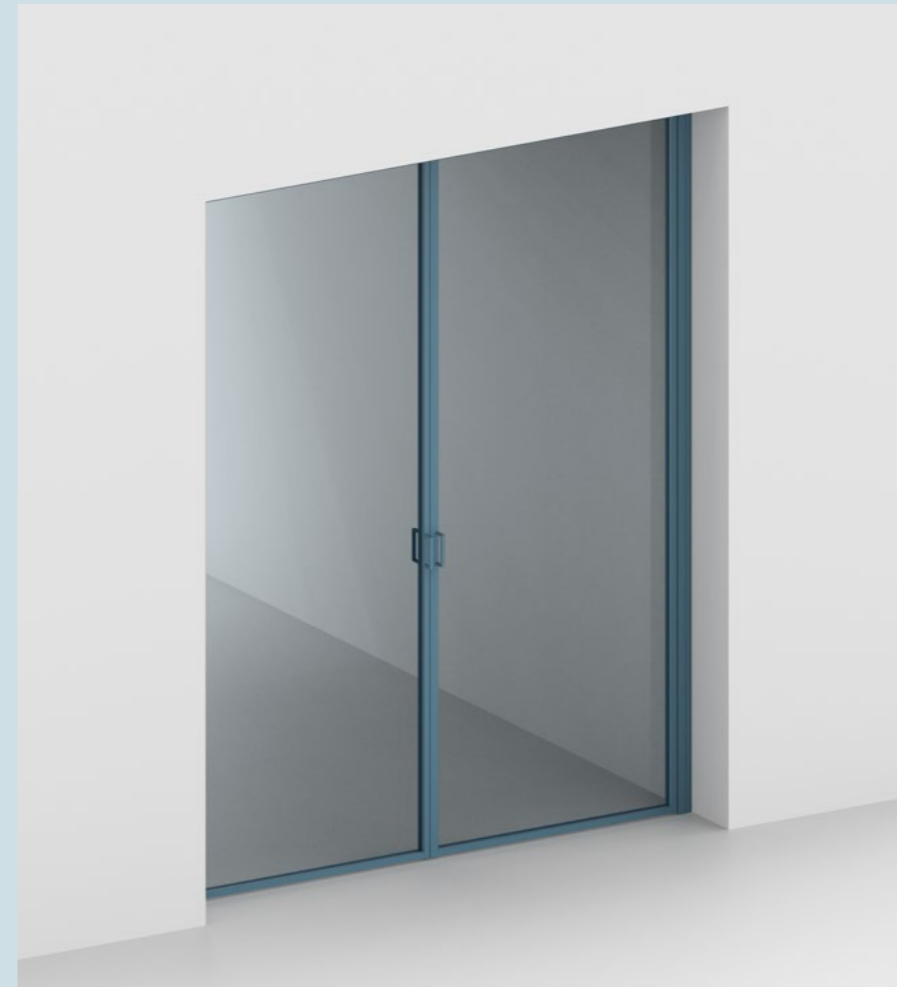

**Porta a due ante simmetriche bilico**  
Pivoting symmetrical double door

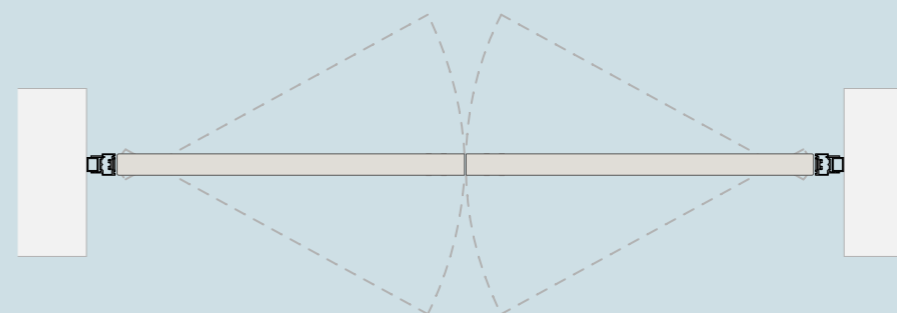

# Stipite telaio bilico

## Pivoting frame jamb

### Compatibilità / Compatibilities

#### Quadra

P. 156

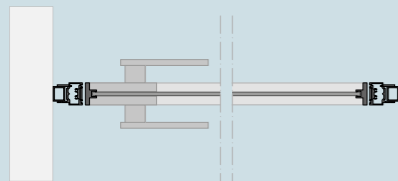

**Quadra vetro singolo bilico**  
Pivoting Quadra single glass

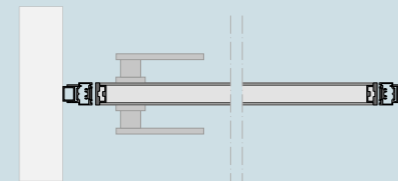

**Quadra doppio vetro bilico**  
Pivoting Quadra double glass

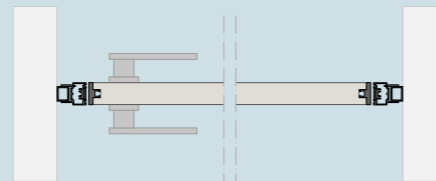

**Quadra pannello bilico**  
Pivoting Quadra panel

#### Prima

P. 158

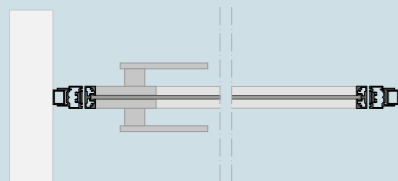

**Prima bilico**  
Pivoting Prima

#### Celine

P. 160

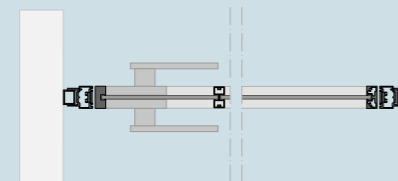

**Celine bilico**  
Pivoting Celine

#### Ri-trait

P. 162

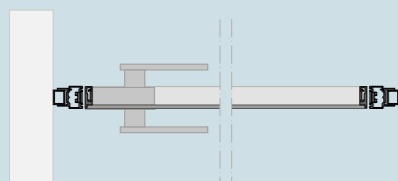

**Ri-trait vetro bilico**  
Pivoting Ri-trait glass to pul

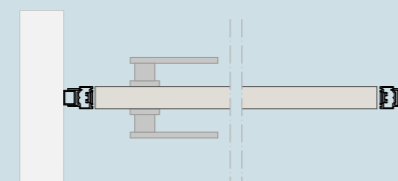

**Ri-trait pannello bilico**  
Pivoting Ri-trait panel

#### Ri-trait 8b

P. 164

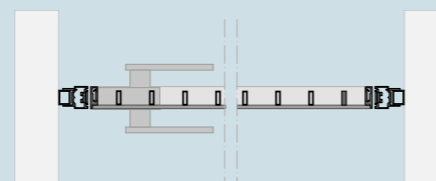

**Ri-trait 8b bilico**  
Pivoting Ri-trait 8b

### Dettagli / Details



1

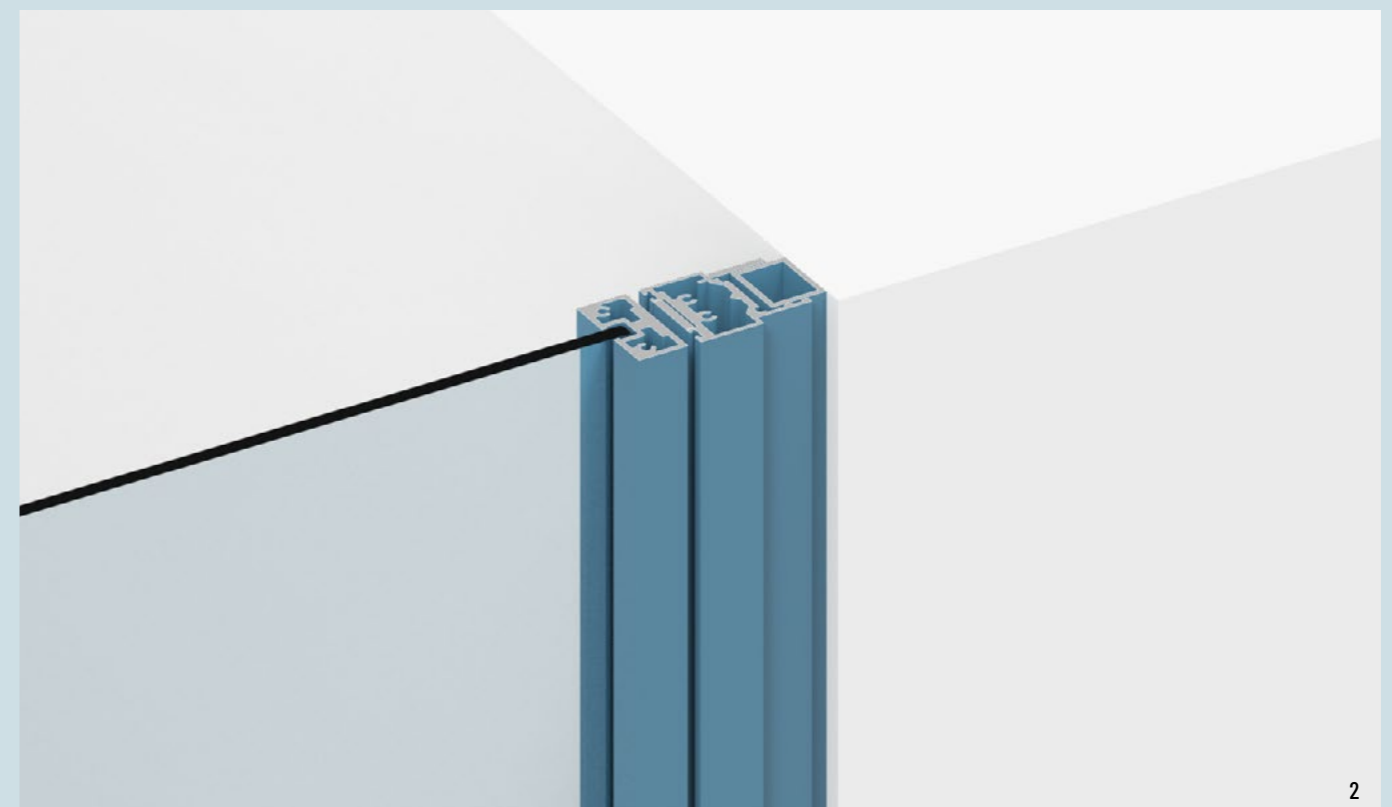

2

**1. Sezione verticale Stipite telaio bilico con Prima**  
1. Vertical section Pivoting frame jamb with Prima

**2. Sezione orizzontale Stipite telaio bilico con Prima**  
2. Horizontal section Pivoting frame jamb with Prima







# Celine senza falso telaio

## Celine without basic door frame

### 1 PORTE SINGOLE STANDARD / STANDARD SINGLE DOORS

Tipo pannello Panel type	Finitura pannello Panel finishing	Finitura stipite e telaio Jamb and frame finishing	Telaio singolo Single frame	Telaio doppio Double frame	Telaio bilico Pivoting frame
Vetro Glass	[1][2] Vetro Cat. A Glass Cat. A	Finitura alluminio anodizzato o RAL 9003 / Anodized aluminum finishing or RAL 9003	€ 1.120	€ 1.420	€ 1.420
	[3][4] [5][6] Vetro Cat. A Glass Cat. A	Finitura alluminio anodizzato o RAL 9003 / Anodized aluminum finishing or RAL 9003	€ 1.220	€ 1.520	€ 1.520

### DIMENSIONI STANDARD / STANDARD SIZES

Porta singola Single door	Pannelli standard Standard panels	Foro architettonico Architectural hole
Telaio singolo Single frame	L 633/733/833 x H 2115	L 695/795/895 x H 2153
Telaio doppio Double frame	L 633/733/833 x H 2115	L 700/800/900 x H 2155
Telaio bilico Pivoting frame	L 633/733/833 x H 2115	L 741/841/941 x H 2176

Al momento dell'ordine specificare il senso di apertura:  
sinistra o destra. / When ordering, specify the opening side of the  
door: left or right.

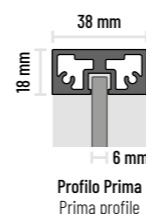

Profilo Prima  
Prima profile

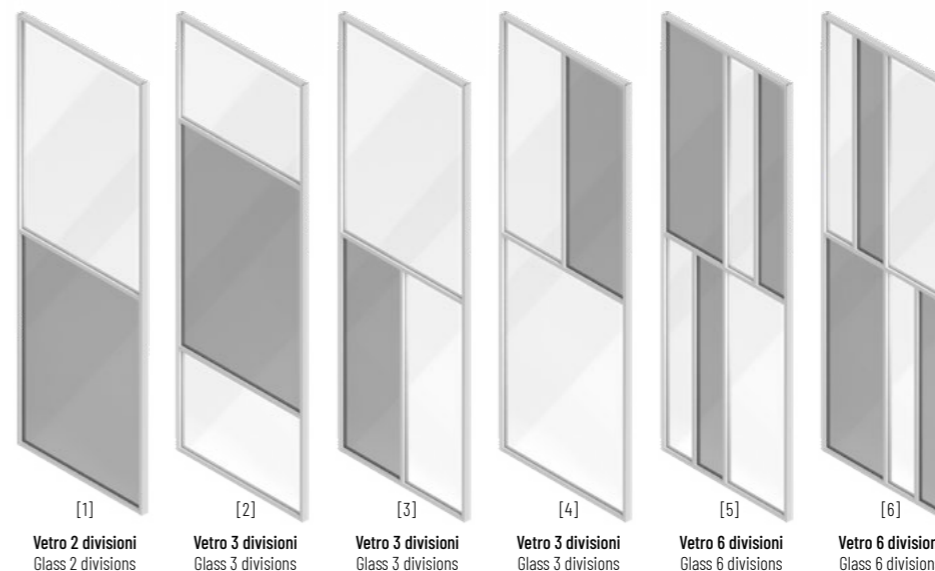

### 2 DIMENSIONI CUSTOM / CUSTOM SIZES

Tipo pannello Panel type	Foro architettonico Architectural hole	L < 1000	L < 1200*
Vetro singolo Single glass	H < 2400	+ € 75	+ € 100
	H < 2700	+ € 200	+ € 250
	H < 3000	+ € 350	+ € 450

\*disponibile solo per porte filomuro bilico  
\*available only for pivoting flush door

### 3 FINITURE / FINISHINGS

Tipo pannello Panel type	Finitura Finishing	P. 30
Vetro singolo Single glass	Vetro Cat. B / Glass Cat. B	+ 10%
	Vetro Cat. C / Glass Cat. C	+ 15%
	Vetro Cat. D / Glass Cat. D	+ 45%
	Vetro Cat. E / Glass Cat. E	+ 75%

Specificare 2 finiture diverse per le divisioni del vetro.  
Specify 2 different finishes for the glass divisions.

In caso di 3 o più finiture diverse sovrapprezzo + 5%  
In case of 3 or more different finishes, surcharge of + 5%

Per finiture di categorie diverse il prezzo viene  
calcolato sulla categoria più alta.  
For finishes of different categories the price is  
calculated on the highest category.

### 5 PORTE A DUE ANTE / DOUBLE DOORS

Tipo pannello Panel type	Porta a due ante Double door	
Tutti i pannelli All panels	Due ante asimmetriche* Asymmetrical double door*	+ 80%
	Due ante simmetriche Symmetrical double door	+ 90%

\*non compatibile con porte telaio bilico  
\*not compatible with pivoting frame door

Porte a due ante disponibili per foro architettonico fino a L2000  
(telaio singolo e telaio doppio) o fino a L2400 (telaio bilico)  
Double doors available for architectural hole up to L2000 (single  
frame and double frame) or up L2400 (pivoting frame)

Porta a due ante asimmetriche è formata da un pannello porta  
L833 + un pannello semifisso di L tale da riempire il foro.  
Symmetrical double door is made up from a door panel L833 +  
a semi-fixed panel of Width such as to fill the hole.

Porta a due ante simmetriche è formata da due pannelli  
di Larghezza uguale  
Symmetrical double door is made up of two panels of equal Width

### 6 SISTEMI DI CHIUSURA / CLOSING SYSTEMS

Tipo pannello Panel type	Sistema di chiusura Closing system	Senza blocco Whitout block	Nottolino Latch free/busy	Chiave Yale Yale key
Vetro singolo Single glass	Serratura integrata con scrocco magnetico <sup>1</sup> Integrated lock with magnetic latch <sup>1</sup>	***	***	***
	Chiusura magnetica senza scrocco <sup>2</sup> Magnetic closing without latch <sup>2</sup>	+ € 50	-	-

<sup>1</sup> non compatibile con porte telaio bilico a due ante  
<sup>1</sup> not compatible with double pivoting frame door

<sup>2</sup> disponibile solo per Porta a due ante simmetriche.  
Per questa opzione è necessario ordinare due elementi.  
<sup>2</sup> available only for Symmetrical double door.  
For this option order two elements.

\*\*\* prezzo incluso nella maniglia  
\*\*\* price included in the handle

### 7 MANIGLIE / HANDLES

Tipo pannello Panel type	Sistema di chiusura Closing system	Maniglia Handle	Solo maniglia Only handle	Nottolino Latch free/busy	Chiave Yale Yale key
Vetro singolo Single glass	Serratura integrata con scrocco magnetico Integrated lock with magnetic latch	Etna	+ € 250	+ € 290	+ € 350
		Vesuvio	+ € 270	+ € 300	+ € 370
	Chiusura magn. snz scrocco Magnetic closing without latch	Vulcano	+ € 250	+ € 290	+ € 350
		Volga	+ € 100	-	-
		Adige 100mm**	+ € 100	-	-
		Adige 300mm**	+ € 200	-	-

\* Per Porta a due ante simmetriche ordinare due elementi  
\* For Symmetrical double door order two elements

\*\* Disponibile solo per porte a due ante e porte bilico  
\*\* Available only for double door and pivoting door

### CODICI PORTE / DOORS CODES

Tipo pannello Panel Type	Telaio singolo / Single frame			Telaio doppio / Double frame			Telaio bilico / Pivoting frame	
	Singola / Single	Porta a due ante / Double door		Singola / Single	Porta a due ante / Double door		Singola / Single	Porta a due ante / Double door
	Tirare Pull	Asimmetriche Asymmetrical	Simmetriche Symmetrical	Tirare Pull	Asimmetriche Asymmetrical	Simmetriche Symmetrical	Bilico Pivoting	Simmetriche Symmetrical
[1]	CLCS21	CLCS210	CLCS211	CLCD21	CLCD210	CLCD211	CLGU41	CLGU410
[2]	CLCS41	CLCS410	CLCS411	CLCD41	CLCD410	CLCD411	CLGU42	CLGU420
[3]	CLCS61	CLCS610	CLCS611	CLCD61	CLCD610	CLCD611	CLGU43	CLGU430
[4]	CLCS81	CLCS810	CLCS811	CLCD81	CLCD810	CLCD811	CLGU44	CLGU440
[5]	CLCS101	CLCS110	CLCS111	CLCD101	CLCD110	CLCD111	CLGU45	CLGU450
[6]	CLCS301	CLCS310	CLCS311	CLCD301	CLCD310	CLCD311	CLGU46	CLGU460

Serratura integrata con scrocco magnetico  
Integrated lock with magnetic latch

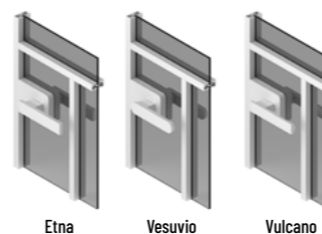

Etna Vesuvio Vulcano

Chiusura magnetica senza scrocco  
Magnetic closing without latch

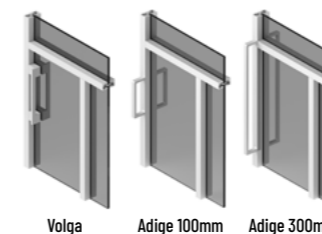

Volga Adige 100mm Adige 300mm

### CODICI SISTEMI DI CHIUSURA / CLOSING SYSTEMS CODES

Sistema di chiusura Closing system	Senza blocco Without block
Chiusura magnetica senza scrocco Magnetic closing without latch	MT-100

### CODICI MANIGLIE / HANDLES CODES

Maniglia Handle	Solo maniglia Only handle	Nottolino Latch free/busy	Chiave Yale Yale key
Etna*	PR-PS10	PR-PS20	PR-PS30
Vesuvio*	PR-PS1000	PR-PS2000	PR-PS3000
Vulcano*	PR-PS100	PR-PS200	PR-PS300
Volga	B	-	-
Adige 100mm	RX	-	-
Adige 300mm	R2X	-	-

\*Maniglia con serratura integrata scrocco magn. / Maniglia with integrated lock with magnetic latch

# Ri-trait senza falso telaio

## Ri-trait without basic door frame

### 1 PORTE SINGOLE STANDARD / STANDARD SINGLE DOORS

Tipo pannello Panel type	Finitura pannello Panel finishing	Finitura stipite e telaio Jamb and frame finishing	Telaio singolo Single frame	Telaio doppio Double frame	Telaio bilico Pivoting frame
Vetro Glass	[1] Vetro Cat. A Glass Cat. A	Finitura alluminio anodizzato Anodized aluminum finishing	€ 1.145	€ 1.445	€ 1.445
Pannello legno Wooden panel	[2] Laccato standard Standard lacquered	Finitura alluminio anodizzato* Anodized aluminum finishing*	€ 1.080	€ 1.380	€ 1.380

\* solo finitura stipite (pannello senza telaio) / only jamb finishing (panel without frame)

### DIMENSIONI STANDARD / STANDARD SIZES

Porta singola Single door	Pannelli standard Standard panels	Foro architettonico Architectural hole
Telaio singolo Single frame	L 633/733/833 x H 2115	L 695/795/895 x H 2153
Telaio doppio Double frame	L 633/733/833 x H 2115	L 700/800/900 x H 2155
Telaio bilico Pivoting frame	L 633/733/833 x H 2115	L 741/841/941 x H 2176

Al momento dell'ordine specificare il senso di apertura: sinistra o destra. / When ordering, specify the opening side of the door: left or right.

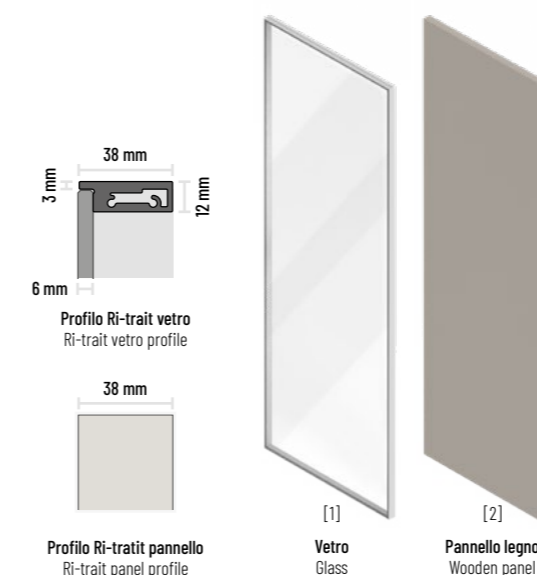

### 2 DIMENSIONI CUSTOM / CUSTOM SIZES

Tipo pannello Panel type	Foro architettonico Architectural hole	L < 1000	L < 1200*
Vetro Glass	H < 2400	+ € 75	+ € 100
	H < 2700	+ € 200	+ € 250
	H < 3000	+ € 350	+ € 450
Pannello legno Wooden panel	H < 2400	+ € 190	+ € 250
	H < 2700	+ € 350	+ € 450

\* disponibile solo per porte filomuro bilico  
\* available only for pivoting flush door

### 3 FINITURE / FINISHINGS

Tipo pannello Panel type	Finitura Finishing	P. 30
Vetro Glass	Vetro Cat. B / Glass Cat. B	+ 10%
	Vetro Cat. C / Glass Cat. C	+ 15%
	Vetro Cat. D / Glass Cat. D	+ 45%
	Vetro Cat. E / Glass Cat. E	+ 75%
Pannello legno Wooden panel	Essenza legno / Wooden essence	+ € 270
	Laccato custom RAL / Custom RAL lacquered	+ € 200

### 4 PORTE A DUE ANTE / DOUBLE DOORS

Tipo pannello Panel type	Porta a due ante Double door	
Tutti i pannelli All panels	Due ante asimmetriche* Asymmetrical double door*	+ 80%
	Due ante simmetriche Symmetrical double door	+ 90%

\* non compatibile con porte telaio bilico  
\* not compatible with pivoting frame door

Porte a due ante disponibili per foro architettonico fino a L2000 (telaio singolo e telaio doppio) o fino a L2400 (telaio bilico)  
Double doors available for architectural hole up to L2000 (single frame and double frame) or up L2400 (pivoting frame)

Porta a due ante asimmetriche è formata da un pannello porta L833 + un pannello semifisso di L tale da riempire il foro.  
Symmetrical double door is made up from a door panel L833 + a semi-fixed panel of Width such as to fill the hole.

Porta a due ante simmetriche è formata da due pannelli di Larghezza uguale  
Symmetrical double door is made up of two panels of equal Width

### 5 SISTEMI DI CHIUSURA / CLOSING SYSTEMS

Tipo pannello Panel type	Sistema di chiusura Closing system	Senza blocco Whitout block	Chiave Patent Patent key	Nottolino Latch free/busy	Chiave Yale Yale key
Vetro Glass	Serratura integrata con scrocco magnetico <sup>1</sup> Integrated lock with magnetic latch <sup>1</sup>	***	-	***	***
	Chiusura magnetica senza scrocco <sup>2</sup> Magnetic closing without latch <sup>2</sup>	+ € 50	-	-	-
Pannello legno Wooden panel	Serratura integrata con scrocco magnetico <sup>1</sup> Integrated lock with magnetic latch <sup>1</sup>	***	-	***	***
	Serr. scrocco magn. per maniglia standard <sup>1</sup> Lock with magnetic latch for standard handles <sup>1</sup>	+ € 90 *	+ € 45	+ € 45	+ € 50 **
	Chiusura magnetica senza scrocco <sup>2</sup> Magnetic closing without latch <sup>2</sup>	+ € 50	-	-	-

<sup>1</sup> non compatibile con porte telaio bilico a due ante  
<sup>1</sup> not compatible with double pivoting frame door

<sup>2</sup> disponibile solo per Porta a due ante simmetriche.  
Per questa opzione è necessario ordinare due elementi.  
<sup>2</sup> available only for Symmetrical double door.  
For this option order two elements.

\* il prezzo comprende serratura e opzione "solo foro maniglia"  
\* price includes lock and "handle hole only" option

\*\* il prezzo non comprende il cilindro Yale  
\*\* price does not include Yale cylinder

\*\*\* prezzo incluso nella maniglia  
\*\*\* price included in the handle

### 6 MANIGLIE / HANDLES

Tipo pannello Panel type	Sistema di chiusura Closing system	Maniglia Handle	Solo maniglia Only handle	Chiave Patent Patent key	Nottolino Latch free/busy	Chiave Yale Yale key
Vetro Glass	Serratura integrata con scrocco magnetico Integrated lock with magnetic latch	Etna	+ € 250	-	+ € 290	+ € 350
		Vesuvio**	+ € 270	-	+ € 300	+ € 370
		Vulcano	+ € 250	-	+ € 290	+ € 350
	Chiusura magn. snz scrocco Magnetic closing without latch	Piave*	+ € 80	-	-	-
Pannello legno Wooden panel	Serratura integrata con scrocco magnetico Integrated lock with magnetic latch	Etna	+ € 250	-	+ € 290	+ € 350
		Vesuvio	+ € 270	-	+ € 300	+ € 370
		Vulcano	+ € 250	-	+ € 290	+ € 350
	Serr. scrocco magnetico per maniglia standard Lock with magnetic latch for standard handles	Etna	+ € 190	+ € 190	+ € 210	+ € 190
		Vesuvio	+ € 230	+ € 230	+ € 250	+ € 230
		Vulcano	+ € 190	+ € 190	+ € 210	+ € 190
		Fuji	+ € 80	+ € 80	+ € 110	+ € 80
		Teide	+ € 80	+ € 80	+ € 110	+ € 80
	Chiusura magn. snz scrocco Magnetic closing without latch	Piave*	+ € 80	-	-	-

\* Per Porta a due ante simmetriche ordinare due elementi  
\* For Symmetrical double door order two elements

\*\* Al momento dell'ordine specificare la scelta tra rosetta e bocchetta quadrate o tonde  
\*\* When ordering, specify the choice between square or round rosette and escutcheon

### CODICI PORTE / DOORS CODES

Tipo pannello Panel Type	Telaio singolo / Single frame			Telaio doppio / Double frame			Telaio bilico / Pivoting frame	
	Singola / Single Tirare Pull	Porta a due ante / Double door Asimmetriche Asymmetrical	Porta a due ante / Double door Simmetriche Symmetrical	Singola / Single Tirare Pull	Porta a due ante / Double door Asimmetriche Asymmetrical	Porta a due ante / Double door Simmetriche Symmetrical	Singola / Single Bilico Pivoting	Porta a due ante / Double door Simmetriche Symmetrical
[1]	TRCS11	TRCS16	TRCS17	TRCD11	TRCD16	TRCD17	TRGU41	TRGU410
[2]	TRCS100	TRCS113	TRCS114	TRCD100	TRCD113	TRCD114	TRGU410	TRGU460



### CODICI SISTEMI DI CHIUSURA / CLOSING SYSTEMS CODES

Sistema di chiusura Closing system	Senza blocco Whitout block	Chiave Patent Patent key	Nottolino Lacht free/busy	Chiave Yale Yale key
Serr. scrocco magnetico per maniglia standard Lock with magnetic latch for standard handles	LVPS1	LVPS1	LVPS2	LVPS3
Chiusura magnetica senza scrocco Magnetic closing without latch	MT-100	-	-	-
Configurazioni serratura scrocco magnetico per maniglia standard Lock with magnetic latch for standard handles configurations	Senza blocco Whitout block	Chiave Patent Patent key	Nottolino Latch free/busy	Chiave Yale Yale key

### CODICI MANIGLIE / HANDLES CODES

Tipo pannello Panel type	Maniglia Handle	Solo maniglia Only handle	Chiave Patent Patent key	Nottolino Lacht free/busy	Chiave Yale Yale key
Vetro Glass	Etna*	RT-FM1	-	RT-FM2	RT-FM3
	Vesuvio*	RT-FM100	-	RT-FM200	RT-FM300
	Vulcano*	RT-FM10	-	RT-FM20	RT-FM30
	Piave	QX	-	-	-
Pannello legno Wooden panel	Etna*	RT-FM4	-	RT-FM5	RT-FM6
	Vesuvio*	RT-FM400	-	RT-FM500	RT-FM600
	Vulcano*	RT-FM40	-	RT-FM50	RT-FM600
	Etna	AC-350C	AC-350C	AC-350N	AC-350Y
	Vesuvio**	AC-550C	AC-550C	AC-550N	AC-550Y
	Vesuvio***	AC-555C	AC-555C	AC-555N	AC-555Y
	Vulcano	AC-450C	AC-450C	AC-450N	AC-450Y
	Fuji****	AC-120C	AC-120C	AC-120N	AC-120Y
	Teide****	AC-220C	AC-220C	AC-220N	AC-120Y
	Piave	QX	-	-	-

\* Maniglia con serratura integrata scrocco magn. / Maniglia with integrated lock with magnetic latch  
\*\* Versione con rosetta e bocchetta quadrate / Square rosette and escutcheon version  
\*\*\* Versione con rosetta e bocchetta tonde / Circular rosette and escutcheon version  
\*\*\*\* Disponibile solo in finitura acciaio / Available only in steel finish

# Ri-trait 8b senza falso telaio

## Ri-trait 8b without basic door frame

### 1 PORTE SINGOLE STANDARD / STANDARD SINGLE DOORS

Tipo pannello Panel type	Finitura pannello Panel finishing	Finitura stipite e telaio Jamb and frame finishing	Telaio singolo Single frame	Telaio doppio Double frame	Telaio bilico Pivoting frame	
Vetro Glass	[1][2] [3][4]	Vetro Cat. A Glass Cat. A	Finitura alluminio anodizzato Anodized aluminum finishing	€ 1.650	€ 1.950	€ 1.950

### DIMENSIONI STANDARD / STANDARD SIZES

Porta singola Single door	Pannelli standard Standard panels	Foro architettonico Architectural hole
Telaio singolo Single frame	L 633/733/833 x H 2115	L 695/795/895 x H 2153
Telaio doppio Double frame	L 633/733/833 x H 2115	L 700/800/900 x H 2155
Telaio bilico Pivoting frame	L 633/733/833 x H 2115	L 741/841/941 x H 2176

Al momento dell'ordine specificare il senso di apertura:  
sinistra o destra. / When ordering, specify the opening side of the door: left or right.

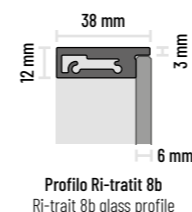

Profilo Ri-trait 8b  
Ri-trait 8b glass profile

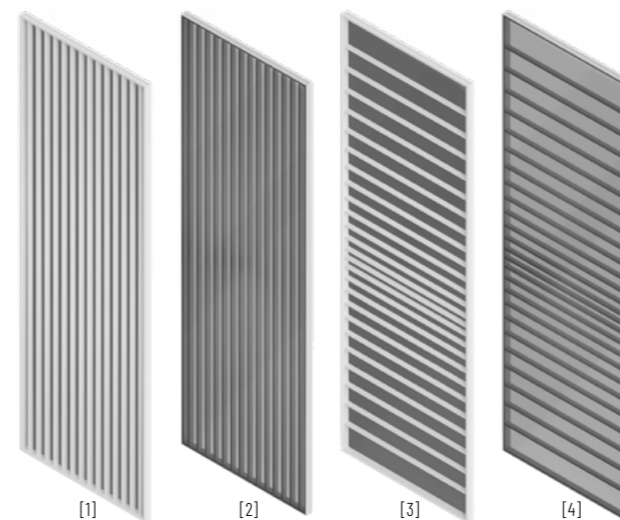

[1] Traversini verticali con fronte a righe  
Vertical plates with front with lines

[2] Traversini verticali con fronte in vetro  
Vertical plates with front in glass

[3] Traversini orizzontali con fronte a righe  
Horizontal plates with front with lines

[4] Traversini orizzontali con fronte in vetro  
Horizontal plates with front in glass

### 2 DIMENSIONI CUSTOM / CUSTOM SIZES

Tipo pannello Panel type	Foro architettonico Architectural hole	L < 1000	L < 1200*
Vetro Glass	H < 2400 H < 2700 H < 3000	+ € 220 + € 360 + € 550	+ € 300 + € 450 + € 750

### 3 FINITURE / FINISHINGS

Tipo pannello Panel type	Finitura Finishing	P. 30
Vetro Glass	Vetro Cat. B / Glass Cat. B Vetro Cat. C / Glass Cat. C Vetro Cat. D / Glass Cat. D	+ 10% + 15% + 45%

### 4 PORTE A DUE ANTE / DOUBLE DOORS

Tipo pannello Panel type	Porta a due ante Double door	
Vetro Glass	Due ante asimmetriche* Asymmetrical double door*	+ 80%
	Due ante simmetriche Symmetrical double door	+ 90%

\*non compatibile con porte telaio bilico  
\*not compatible with pivoting frame door

Porte a due ante disponibili per foro architettonico fino a L2000 (telaio singolo e telaio doppio) o fino a L2400 (telaio bilico)  
Double doors available for architectural hole up to L2000 (single frame and double frame) or up to L2400 (pivoting frame)

Porta a due ante asimmetriche è formata da un pannello porta L833 + un pannello semifisso di L tale da riempire il foro.  
Symmetrical double door is made up from a door panel L833 + a semi-fixed panel of Width such as to fill the hole.

Porta a due ante simmetriche è formata da due pannelli di Larghezza uguale  
Symmetrical double door is made up of two panels of equal Width

### 5 SISTEMI DI CHIUSURA / CLOSING SYSTEMS

Tipo pannello Panel type	Sistema di chiusura Closing system	Senza blocco Without block	Nottolino Latch free/busy	Chiave Yale Yale key
Vetro Glass	Serratura integrata con scrocco magnetico <sup>1</sup> Integrated lock with magnetic latch <sup>1</sup>	***	***	***
	Chiusura magnetica senza scrocco <sup>2</sup> Magnetic closing without latch <sup>2</sup>	+ € 50	-	-

<sup>1</sup> non compatibile con porte telaio bilico a due ante  
<sup>1</sup> not compatible with double pivoting frame door

<sup>2</sup> disponibile solo per Porta a due ante simmetriche.  
Per questa opzione è necessario ordinare due elementi.  
<sup>2</sup> available only for Symmetrical double door.  
For this option order two elements.

\*\*\* prezzo incluso nella maniglia  
\*\*\* price included in the handle

### 6 MANIGLIE / HANDLES

Tipo pannello Panel type	Sistema di chiusura Closing system	Maniglia Handle	Solo maniglia Only handle	Nottolino Latch free/busy	Chiave Yale Yale key
Vetro Glass	Serratura integrata con scrocco magnetico Integrated lock with magnetic latch	Etna Vesuvio Vulcano	+ € 250 + € 270 + € 250	+ € 290 + € 300 + € 290	+ € 350 + € 370 + € 350
	Chiusura magn. snz scrocco Magnetic closing without latch	Adige 200mm*	+ € 100	-	-

\* Per Porta a due ante simmetriche ordinare due elementi  
\* For Symmetrical double door order two elements

### CODICI PORTE / DOORS CODES

Tipo pannello Panel Type	Telaio singolo / Single frame			Telaio doppio / Double frame			Telaio bilico / Pivoting frame	
	Singola / Single Tirare Pull	Porta a due ante / Double door Asimmetriche Asymmetrical	Porta a due ante / Double door Simmetriche Symmetrical	Singola / Single Tirare Pull	Porta a due ante / Double door Asimmetriche Asymmetrical	Porta a due ante / Double door Simmetriche Symmetrical	Singola / Single Bilico Pivoting	Porta a due ante / Double door Simmetriche Symmetrical
[1]	R8CS1	R8CS11	R8CS12	R8CD1	R8CD11	R8CD12	R8GB41	R8GB410
[2]	R8CS5	R8CS15	R8CS16	R8CD5	R8CD15	R8CD16	R8GB42	R8GB420
[3]	R8CS10	R8CS20	R8CS21	R8CD10	R8CD20	R8CD21	R8GB43	R8GB430
[4]	R8CS50	R8CS60	R8CS61	R8CD50	R8CD60	R8CD61	R8GB44	ROGB440

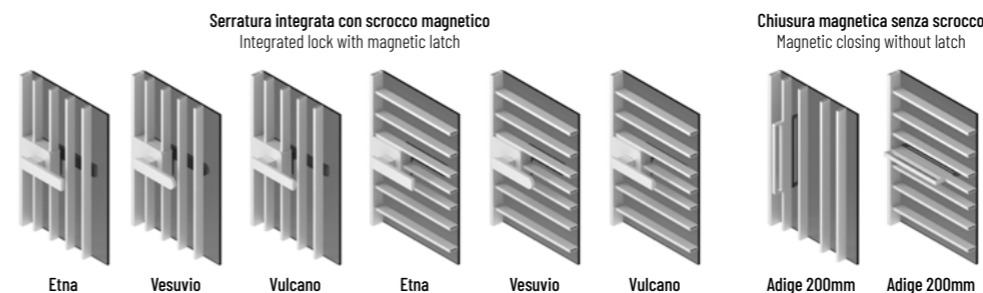

### CODICI SISTEMI DI CHIUSURA / CLOSING SYSTEMS CODES

Sistema di chiusura Closing system	Senza blocco Without block
Chiusura magnetica senza scrocco Magnetic closing without latch	MT-100

### CODICI MANIGLIE / HANDLES CODES

Maniglia Handle	Solo maniglia Only handle	Nottolino Latch free/busy	Chiave Yale Yale key
Etna*	RT-FM1	RT-FM2	RT-FM3
Vesuvio*	RT-FM100	RT-FM200	RT-FM300
Vulcano*	RT-FM10	RT-FM20	RT-FM30
Adige 200mm	MX	-	-

\*Maniglia con serratura integrata scrocco magn. / Maniglia with integrated lock with magnetic latch

# Stipite portale battente

## Hinged portal jamb

Lo stipite portale è una soluzione architettonica che permette di installare in un vano architettonico una sottile cornice a filo parete, disgiunta dalla parete stessa da uno scuretto costante su tutto lo sviluppo. Questo stipite sofisticato può definire gli spazi come portale o accogliere una serie di accessori che permettono di delineare imbotti in diversi materiali, cornici luminose.

The portal jamb is an architectural solution that allows for a slim frame installed in an architectural opening, flush with the wall, but separated from the wall itself by an even shadow line along its entire length. This sophisticated jamb can define spaces as a portal or support a series of accessories, making it possible to outline intradoses in various materials, and lit-up frames.

### Porta singola / Single door



### Porta a due ante / Double door

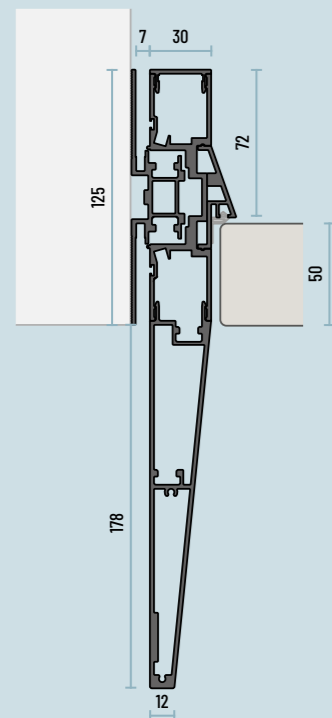

Porta singola  
Single door

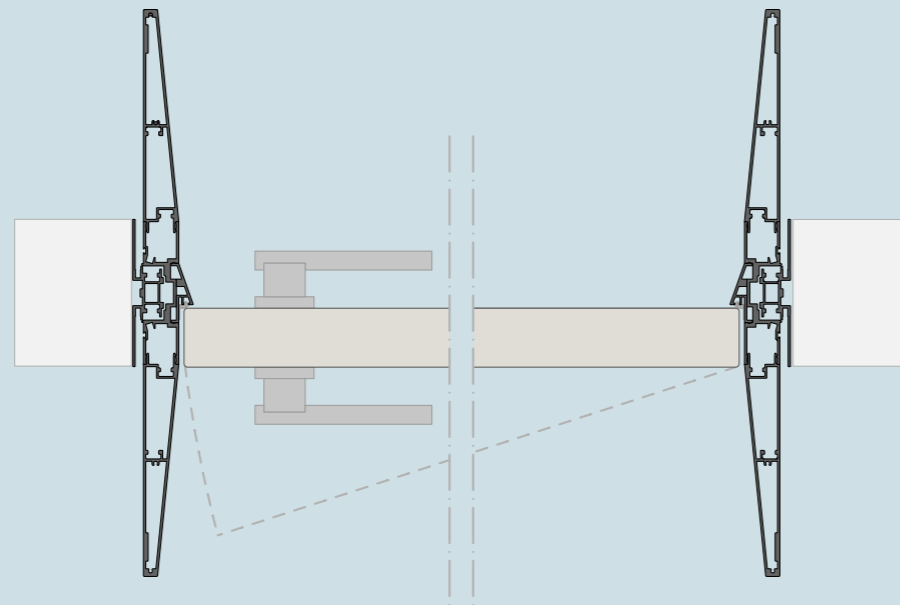

Porta a due ante simmetriche  
Symmetrical double door

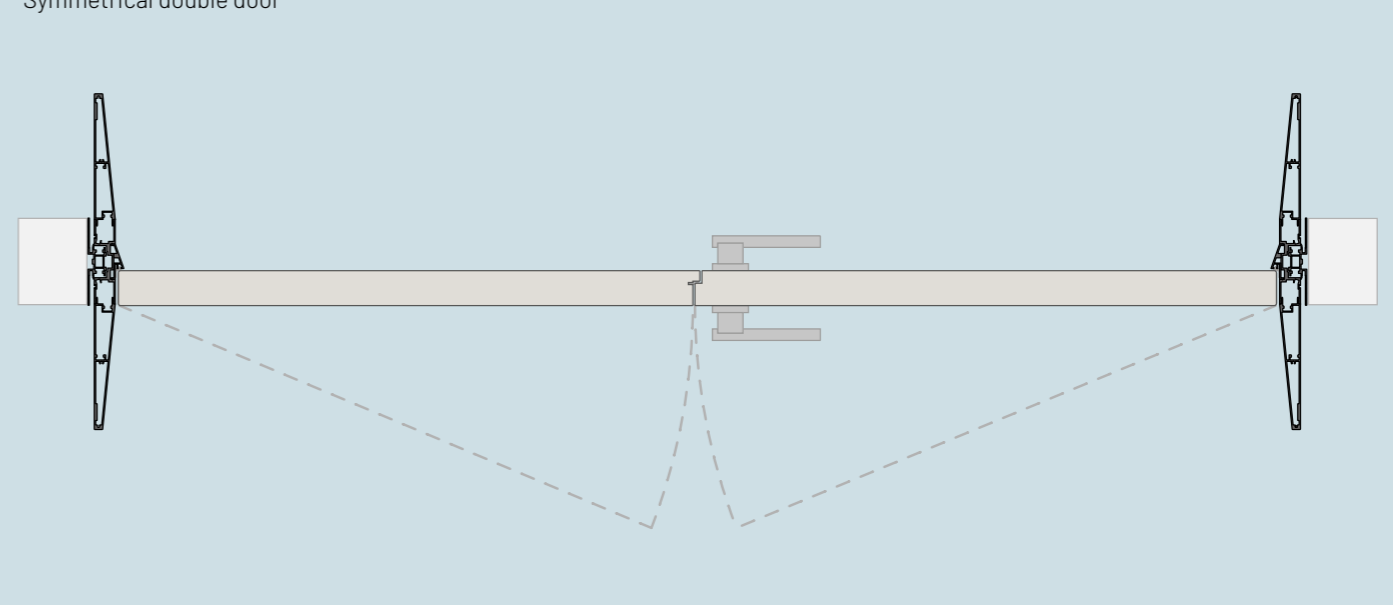

Dimensioni (mm) stipite portale battente  
Dimensions (mm) hinged portal jamb

# Stipite portale battente

## Hanged portal jamb

### Compatibilità / Compatibilities

#### Entre-deux

P. 178

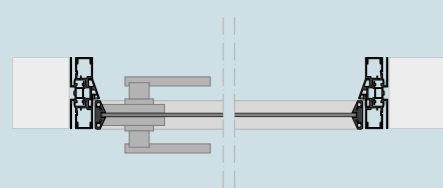

**Entre-deux vetro su parete con coprifili in alluminio**  
Entre-deux glass on the wall with aluminium cover

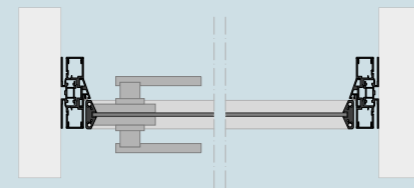

**Entre-deux vetro su corridoio con coprifili in alluminio**  
Entre-deux glass on corridor with aluminium cover

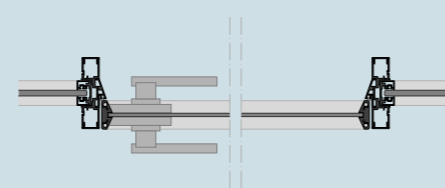

**Entre-deux vetro su sistema All Ways con coprifili in alluminio**  
Entre-deux glass on All Ways system with aluminium cover

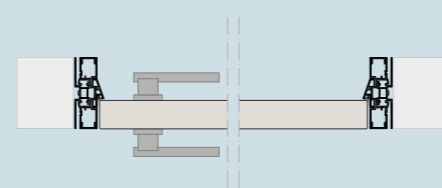

**Entre-deux pannello su parete con coprifili in alluminio**  
Entre-deux panel on the wall with aluminium cover

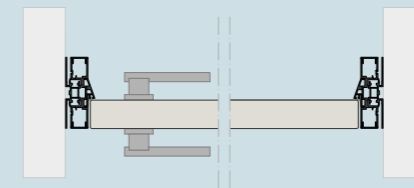

**Entre-deux pannello su corridoio con coprifili in alluminio**  
Entre-deux panel on corridor with aluminium cover

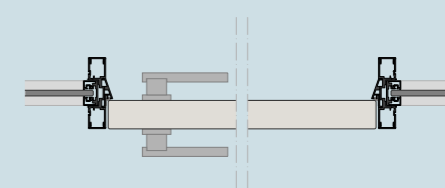

**Entre-deux pannello su sistema All Ways con coprifili in alluminio**  
Entre-deux panel on All Ways system with aluminium cover

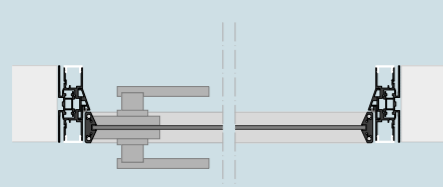

**Entre-deux vetro su parete con coprifili Led**  
Entre-deux glass on the wall with Led cover

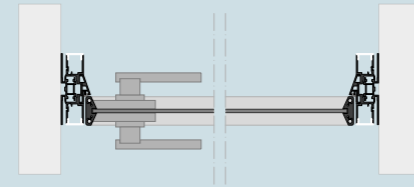

**Entre-deux vetro su corridoio con coprifili Led**  
Entre-deux glass on corridor with Led cover

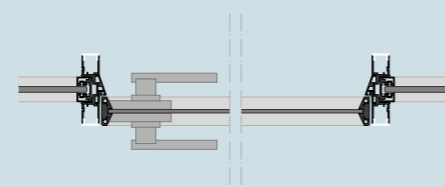

**Entre-deux vetro su sistema All Ways con coprifili Led**  
Entre-deux glass on All Ways system with Led cover

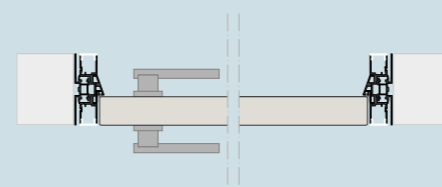

**Entre-deux pannello su parete con coprifili Led**  
Entre-deux panel on the wall with Led cover

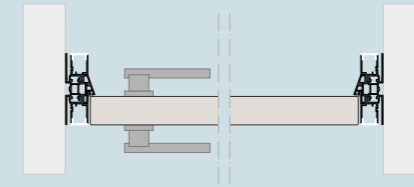

**Entre-deux pannello su corridoio con coprifili Led**  
Entre-deux panel on corridor with Led cover

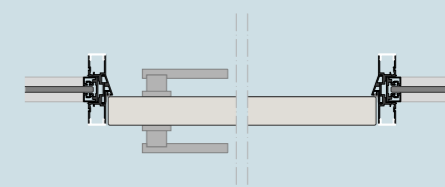

**Entre-deux pannello su sistema All Ways con coprifili Led**  
Entre-deux panel on All Ways system with Led cover

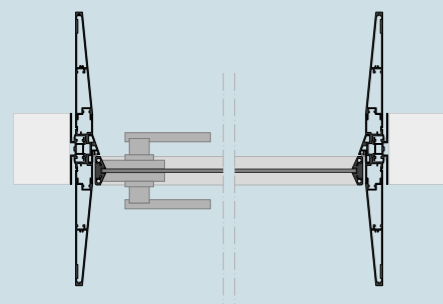

**Entre-deux vetro su parete con doppia ala alluminio**  
Entre-deux glass on the wall with double aluminium wings

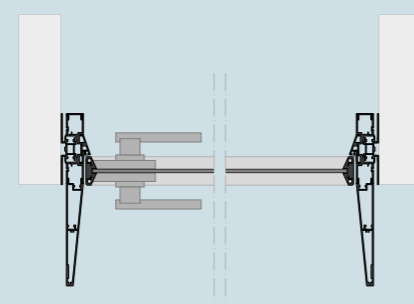

**Entre-deux vetro su corridoio con ala e coprifilo alluminio**  
Entre-deux glass on corridor with aluminium wing and cover

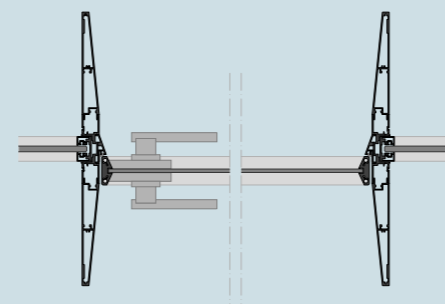

**Entre-deux vetro su sistema All Ways con doppia ala alluminio**  
Entre-deux glass on All Ways system with double aluminium wings

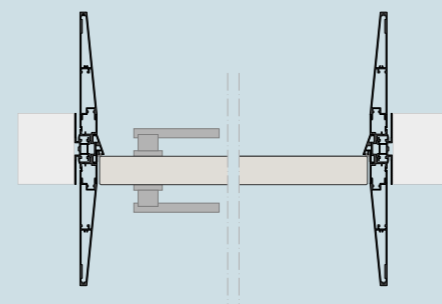

**Entre-deux pannello su parete con doppia ala alluminio**  
Entre-deux panel on the wall with double aluminium wings

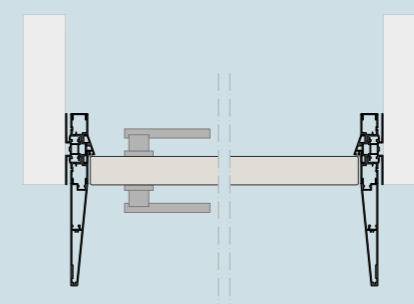

**Entre-deux pannello su corridoio con ala e coprifilo alluminio**  
Entre-deux panel on corridor with aluminium wing and cover

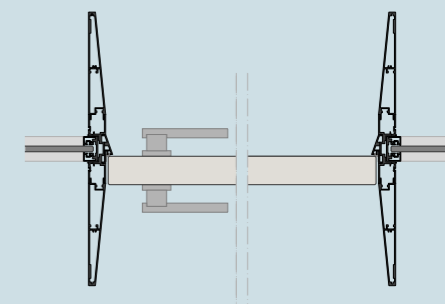

**Entre-deux pannello su sistema All Ways con doppia ala alluminio**  
Entre-deux panel on All Ways system with double aluminium wings

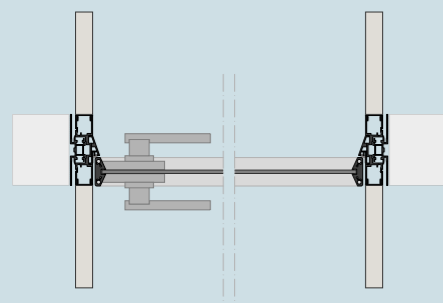

**Entre-deux vetro su parete con doppia ala legno**  
Entre-deux glass on the wall con with double wooden wings

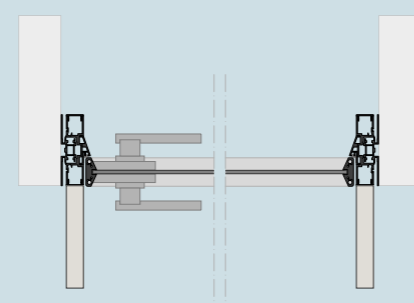

**Entre-deux vetro su corridoio con ala legno e coprifilo alluminio**  
Entre-deux glass on corridor with wooden wing and aluminium cover

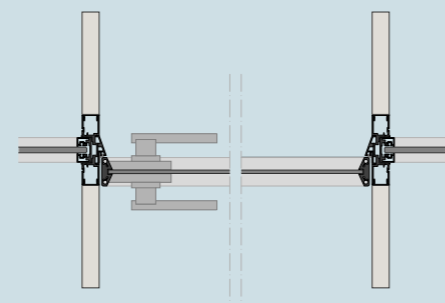

**Entre-deux vetro su sistema All Ways con doppia ala legno**  
Entre-deux glass on All Ways system with double wooden wings

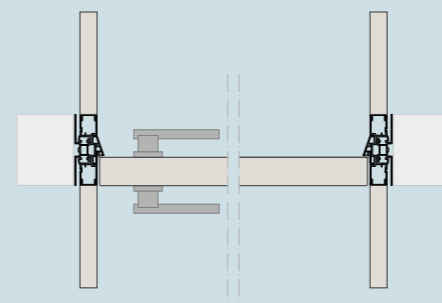

**Entre-deux pannello su parete con doppia ala legno**  
Entre-deux panel on the wall con with double wooden wings

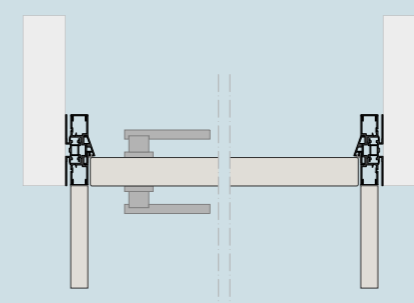

**Entre-deux pannello su corridoio con ala legno e coprifilo alluminio**  
Entre-deux panel on corridor with wooden wing and aluminium cover

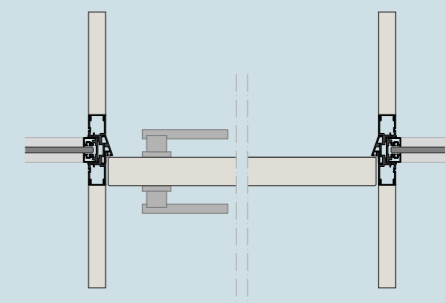

**Entre-deux pannello su sistema All Ways con doppia ala legno**  
Entre-deux panel on All Ways system with double wooden wings

Informazioni generali / General informations  
Porte battenti con cornice / Hinged door and frame  
Porte filomuro / Flush door  
Porte effetto filomuro / Flush-effect door  
Porte a scomparsa / Pocket door  
Pareti divisorie o girevoli / Sliding or pivoting panels  
Pani scorrevoli o girevoli / Sliding or pivoting panels  
Pareti divisorie / Partition wall  
Boiserie / Boiserie  
Cabine armadio / Walk-in closet  
Librerie / Bookcase  
Tavoli / Table

Informazioni generali / General informations  
Porte battenti con cornice / Hinged door and frame  
Porte filomuro / Flush door  
Porte effetto filomuro / Flush-effect door  
Porte a scomparsa / Pocket door  
Pareti divisorie o girevoli / Sliding or pivoting panels  
Pani scorrevoli o girevoli / Sliding or pivoting panels  
Pareti divisorie / Partition wall  
Boiserie / Boiserie  
Cabine armadio / Walk-in closet  
Librerie / Bookcase  
Tavoli / Table

# Stipite portale battente

## Hinged portal jamb

### Dettagli / Details

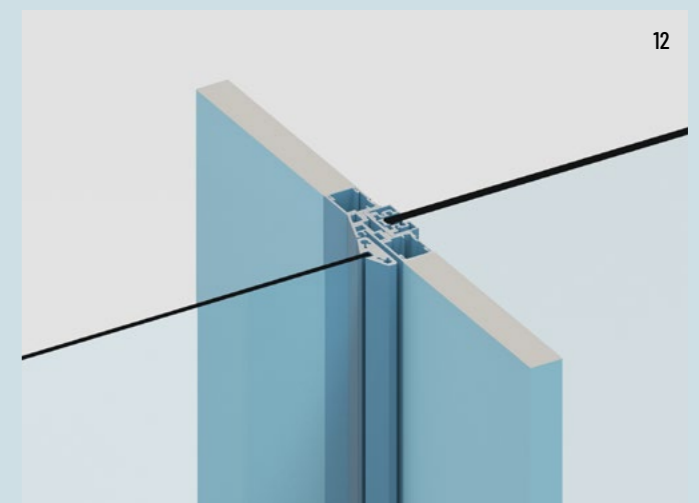
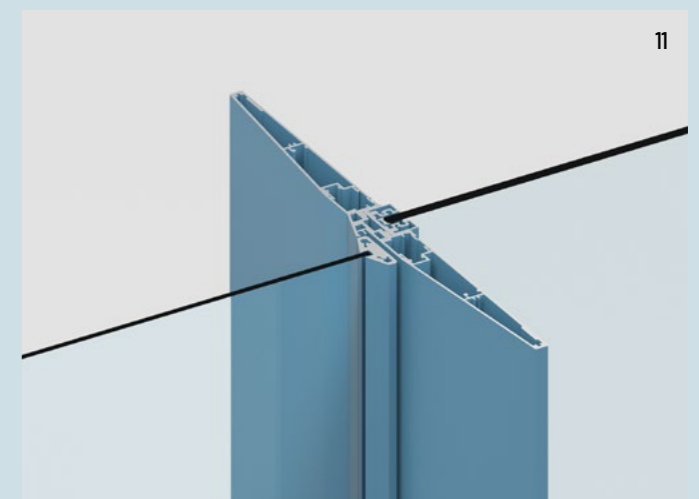
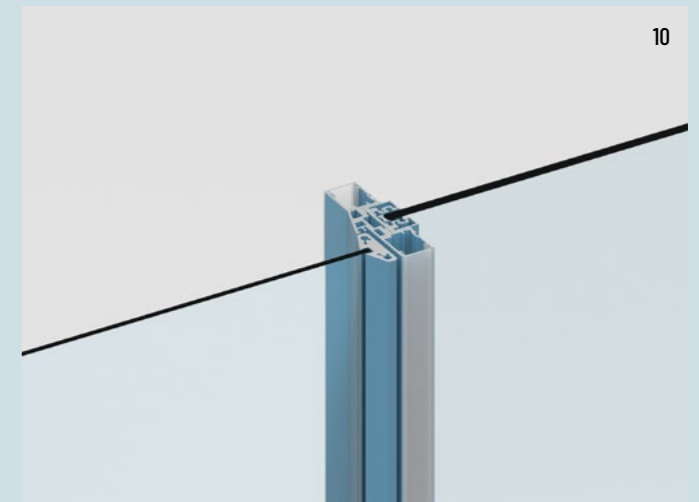
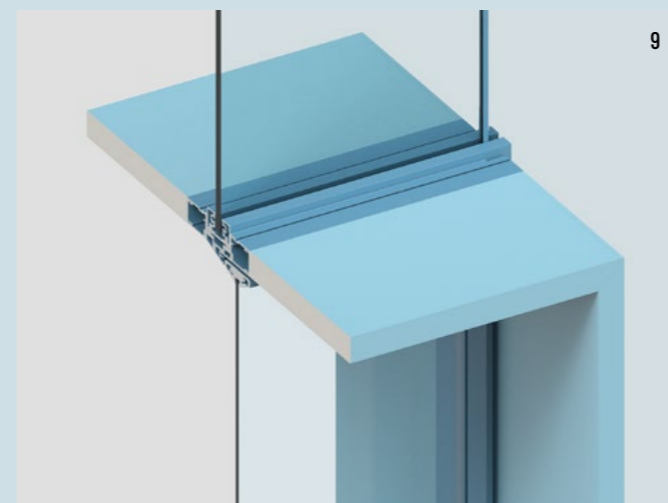
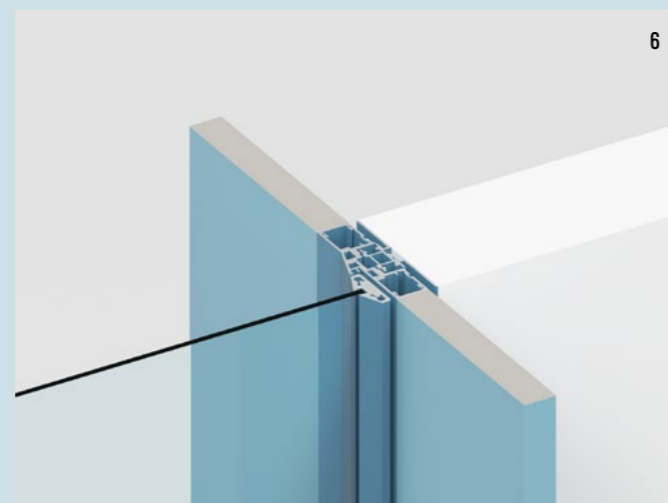
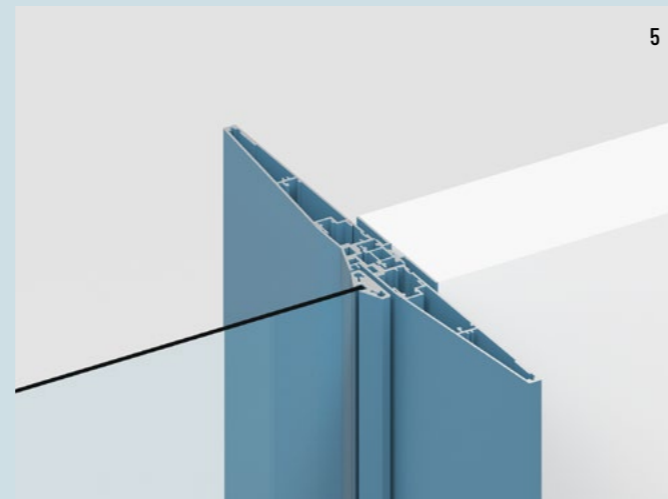
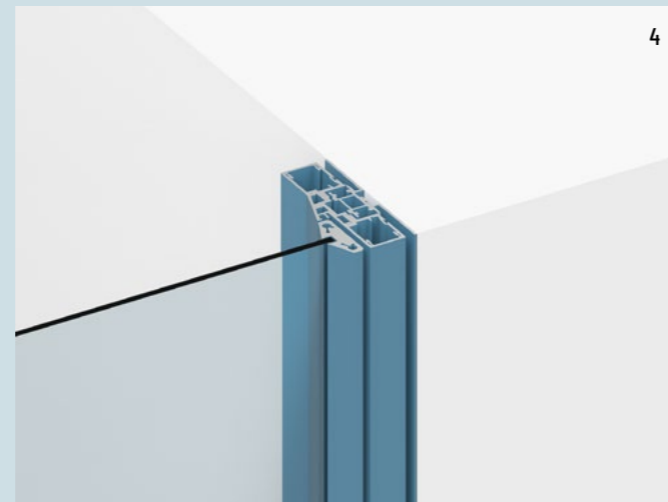
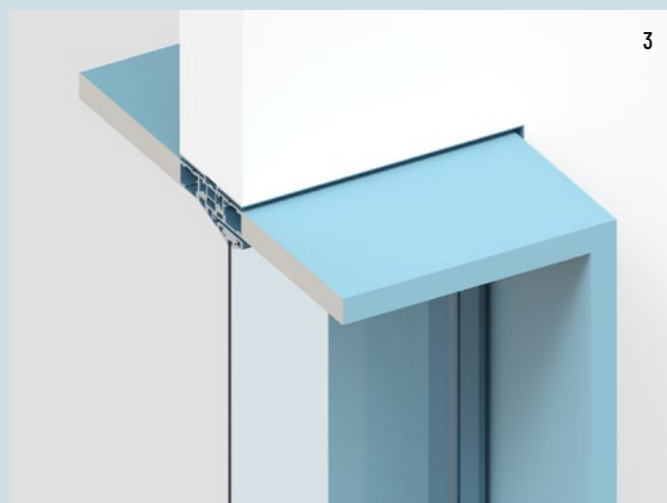

**1. Sezione verticale Stipite portale battente con porta Entre-deux e coprifili alluminio, corridoio**  
1. Vertical section Hinged portal jamb with Entre-deux door and aluminium cover, corridor

**2. Sezione verticale Stipite portale battente con porta Entre-deux e ali alluminio, parete**  
2. Vertical section Hinged portal jamb with Entre-deux door and aluminium wings, wall

**3. Sezione verticale Stipite portale battente con porta Entre-deux e ali legno, parete**  
3. Vertical section Hinged portal jamb with Entre-deux door and wooden wings, wall

**4. Sezione orizzontale Stipite portale battente con porta Entre-deux e coprifili alluminio, corridoio**  
4. Horizontal section Hinged portal jamb with Entre-deux door and aluminium cover, corridor

**5. Sezione orizzontale Stipite portale battente con porta Entre-deux e ali alluminio, parete**  
5. Horizontal section Hinged-portal jamb with Entre-deux door and aluminium wings, wall

**6. Sezione orizzontale Stipite portale battente con porta Entre-deux e ali legno, parete**  
6. Horizontal section Hinged portal jamb with Entre-deux door and wooden wings, wall

**7. Sezione verticale Stipite portale battente con porta Entre-deux e coprifili led, sistema All Ways**  
7. Vertical section Hinged portal jamb with Entre-deux door and led cover, All Ways system

**8. Sezione verticale Stipite portale battente con porta Entre-deux e ali alluminio, sistema All Ways**  
8. Vertical section Hinged portal jamb with Entre-deux door and aluminium wings, All Ways system

**9. Sezione verticale Stipite portale battente con porta Entre-deux e ali legno, sistema All Ways**  
9. Vertical section Hinged portal jamb with Entre-deux door and wooden wings, All Ways system

**10. Sezione orizzontale Stipite portale battente con porta Entre-deux e coprifili led, sistema All Ways**  
10. Horizontal section Hinged portal jamb with Entre-deux door and led cover, All Ways system

**11. Sezione orizzontale Stipite portale battente con porta Entre-deux e ali alluminio, sistema All Ways**  
11. Horizontal section Hinged portal jamb with Entre-deux door and aluminium wings, All Ways system

**12. Sezione orizzontale Stipite portale battente con porta Entre-deux e ali legno, sistema All Ways**  
12. Horizontal section Hinged portal jamb with Entre-deux door and wooden wings, All Ways system

# Stipite portale bilico

## Pivoting portal jamb

Lo stipite portale bilico permette di spostare la soglia della porta rispetto alla superficie della parete agendo sull'equilibrio tra gli spazi architettonici. Nella versione stipite portale bilico la porta è fissata sull'estremità delle ali.

The portal jamb with pivot allows you to move the threshold of the door respect the wall surface, acting on the balance between the architectural spaces. In the portal jamb with pivot version, the door is fixed on the extremity of the wings.

### Porta singola / Single door



### Porta a due ante / Double door

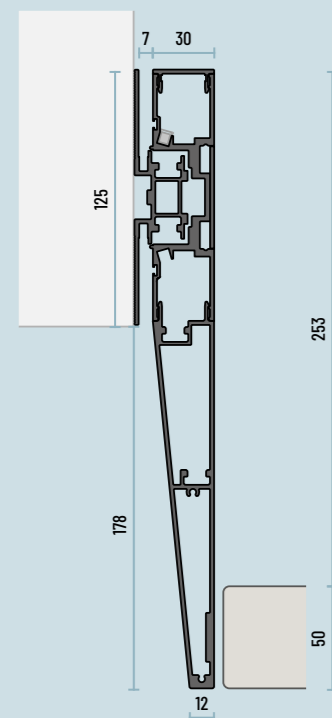

Dimensioni (mm) stipite portale bilico  
Dimensions (mm) pivoting portal jamb

#### Porta singola bilico Pivoting single pull

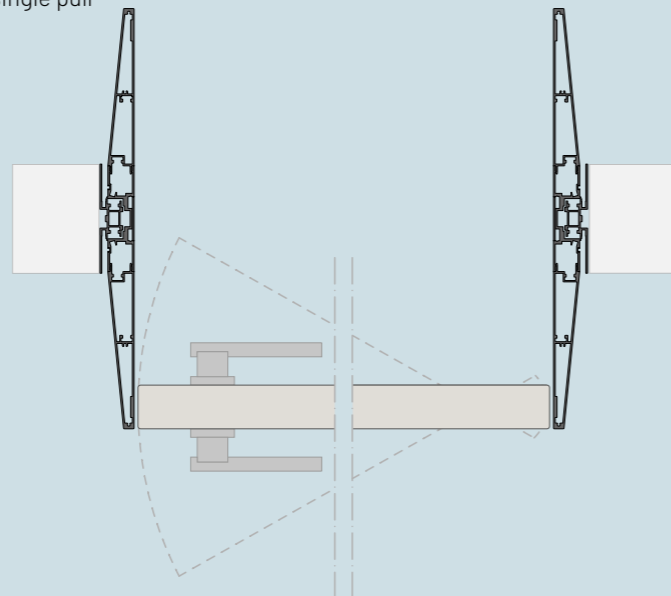

#### Porta a due ante asimmetriche bilico Pivoting symmetrical double door

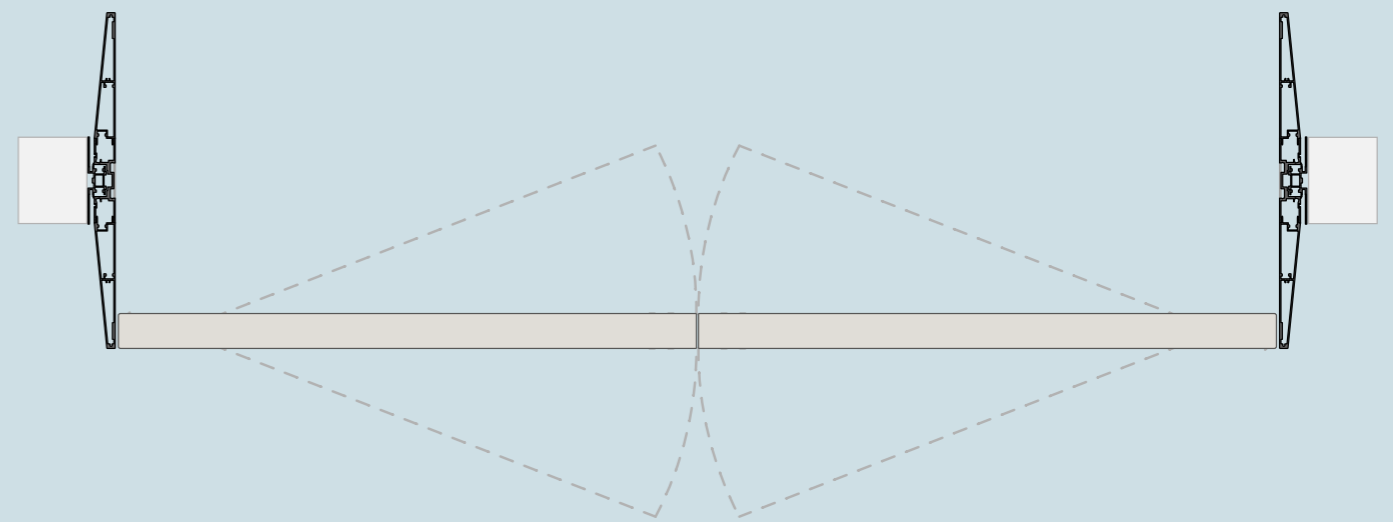

# Stipite portale bilico

## Pivoting portal jamb

### Compatibilità / Compatibilities

#### Entre-deux

P. 178

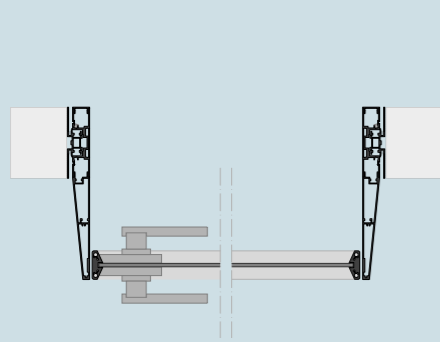

**Entre-deux vetro su parete con ala e coprifilo alluminio**  
Entre-deux glass on the wall with aluminium wing and cover

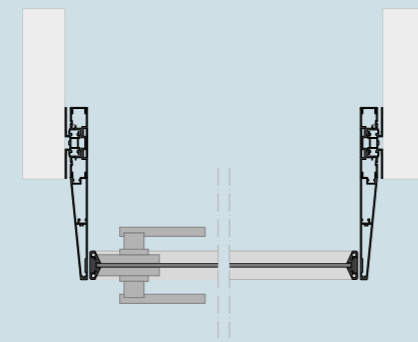

**Entre-deux vetro su corridoio con ala e coprifilo alluminio**  
Entre-deux glass on corridor with aluminium wing and cover

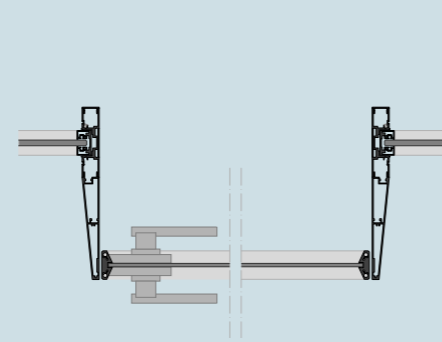

**Entre-deux vetro su sistema All Ways con ala e coprifilo in alluminio**  
Entre-deux glass on All Ways system with aluminium wing and cover

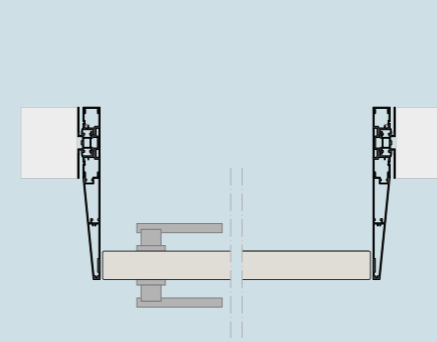

**Entre-deux pannello legno su parete con ala e coprifilo in alluminio**  
Entre-deux wooden panel on the wall with aluminium wing and cover

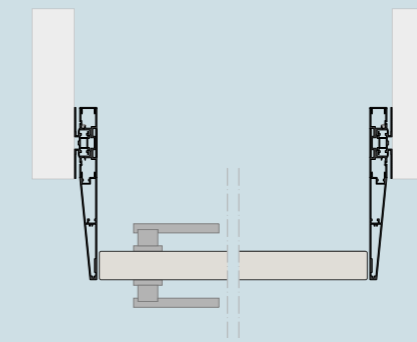

**Entre-deux pannello legno su corridoio con ala e coprifilo in alluminio**  
Entre-deux wooden panel on corridor with aluminium wing and cover

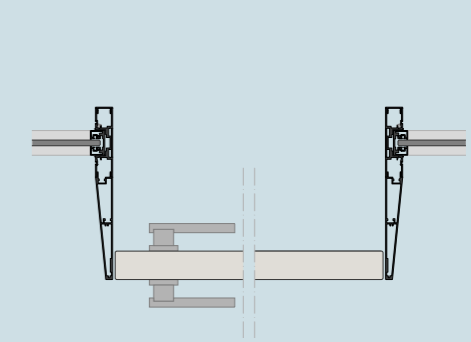

**Entre-deux pannello legno su sistema All Ways con ala e coprifilo in alluminio**  
Entre-deux wooden panel on All Ways system with aluminium wing and cover

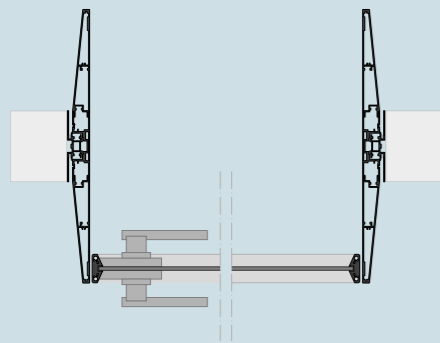

**Entre-deux vetro su parete con doppia ala in alluminio**  
Entre-deux glass on the wall with double aluminium wings

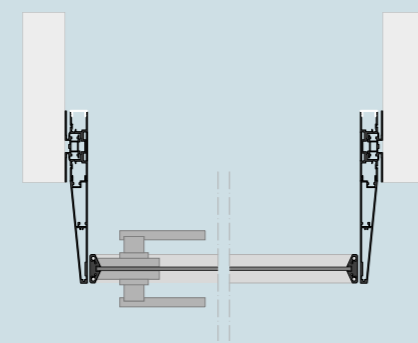

**Entre-deux vetro su corridoio con ala in alluminio e coprifilo led**  
Entre-deux glass on corridor with aluminium wing and led cover

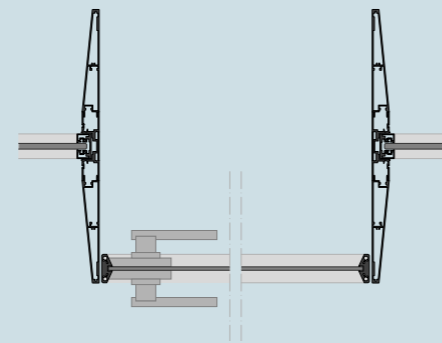

**Entre-deux vetro su sistema All Ways doppia ala in alluminio**  
Entre-deux glass on All Ways system with double aluminium wings

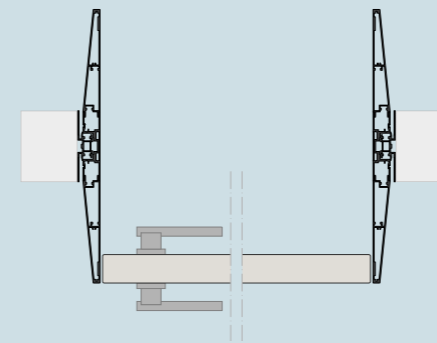

**Entre-deux pannello legno su parete con doppia ala in alluminio**  
Entre-deux wooden panel on the wall with double aluminium wings

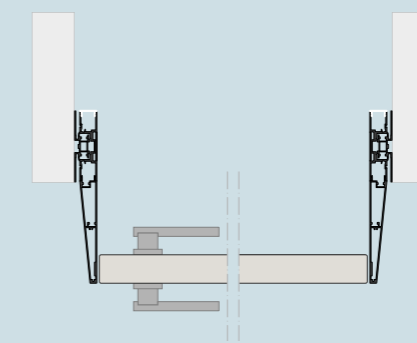

**Entre-deux pannello legno su corridoio con ala in alluminio e coprifilo led**  
Entre-deux wooden panel on corridor with aluminium wing and led cover

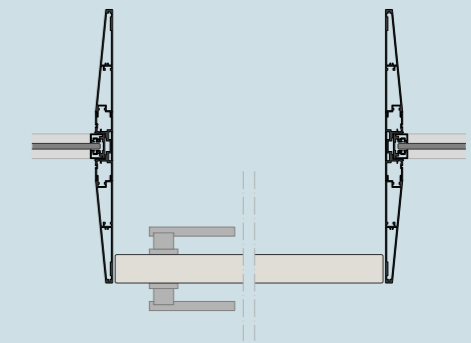

**Entre-deux pannello legno su sistema All Ways doppia ala in alluminio**  
Entre-deux wooden panel on All Ways system with double aluminium wings

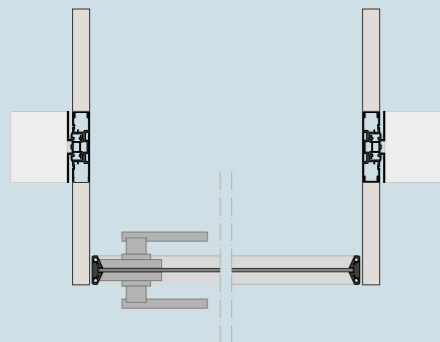

**Entre-deux vetro su parete con doppia ala in legno**  
Entre-deux glass on the wall with double wooden wings

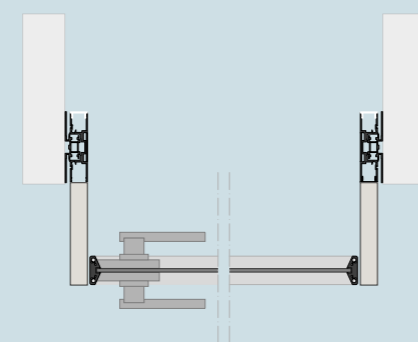

**Entre-deux vetro su corridoio con ala in legno e coprifilo led**  
Entre-deux glass on corridor with wooden wing and led cover

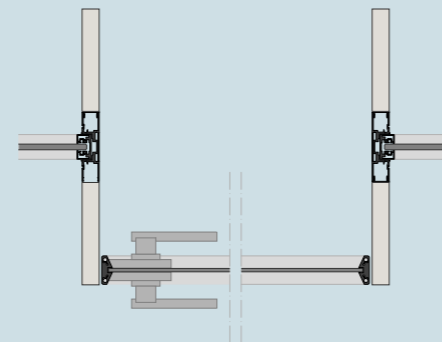

**Entre-deux vetro su sistema All Ways doppia ala in legno**  
Entre-deux glass on All Ways system with double wooden wings

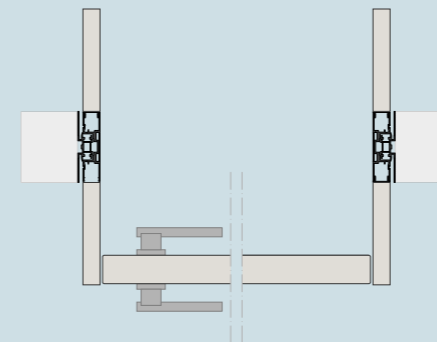

**Entre-deux pannello legno su parete con doppia ala in legno**  
Entre-deux wooden panel on the wall with double wooden wings

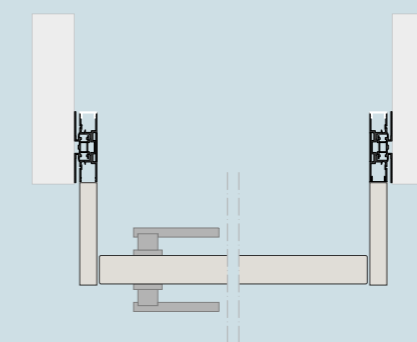

**Entre-deux pannello legno su corridoio con ala in legno e coprifilo led**  
Entre-deux wooden panel on corridor with wooden wing and led cover

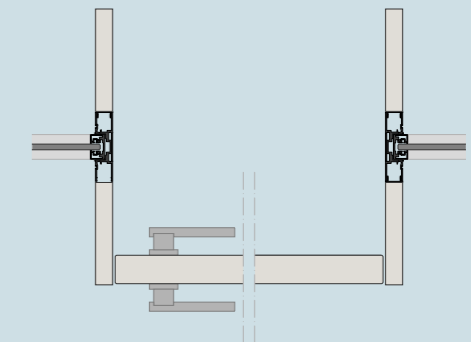

**Entre-deux pannello legno su sistema All Ways doppia ala in legno**  
Entre-deux wooden panel on All Ways system with double wooden wings



# Stipite portale bilico

## Pivoting portal jamb

### Dettagli / Details

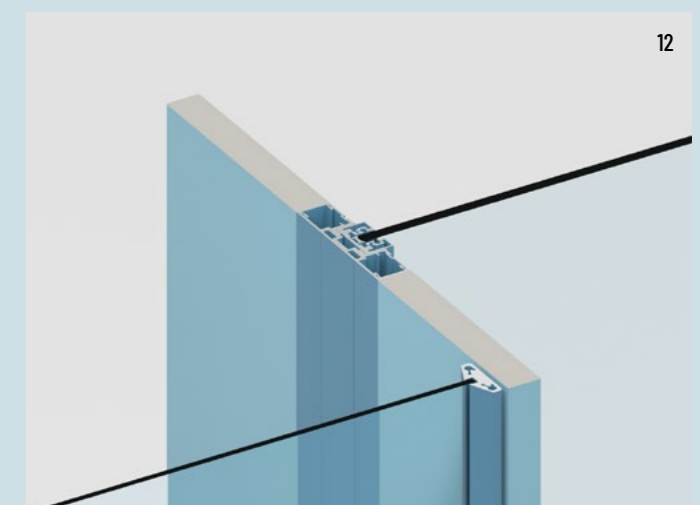
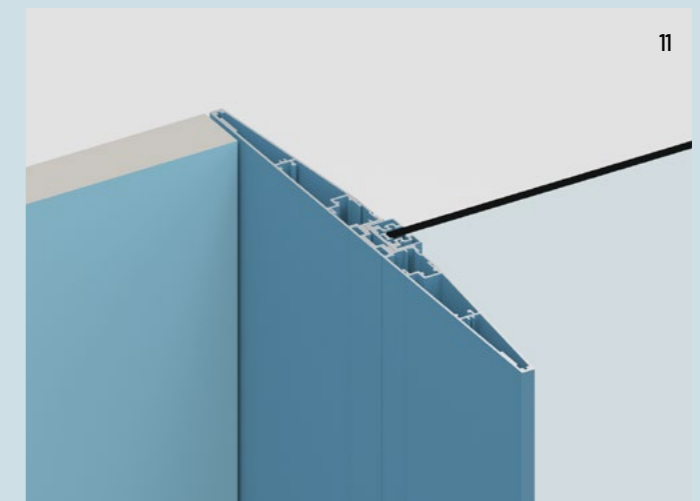
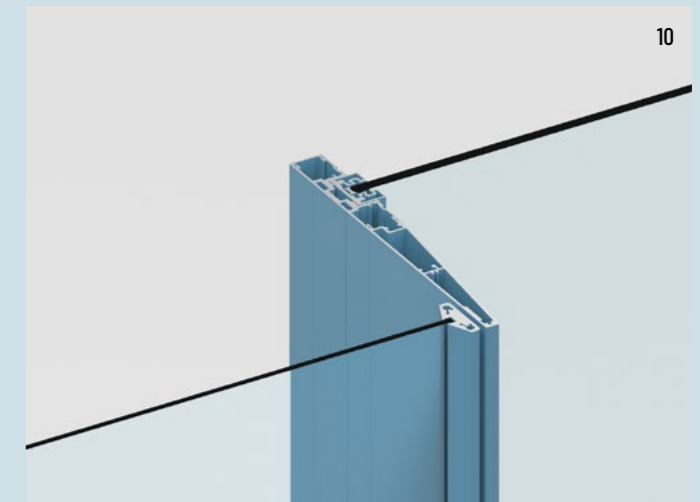
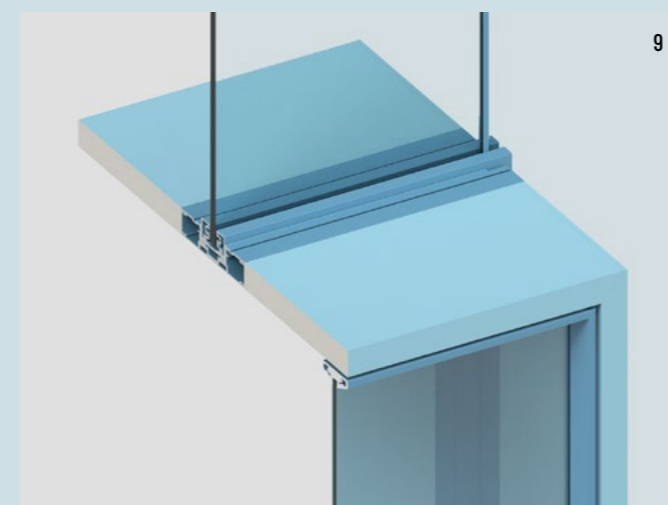
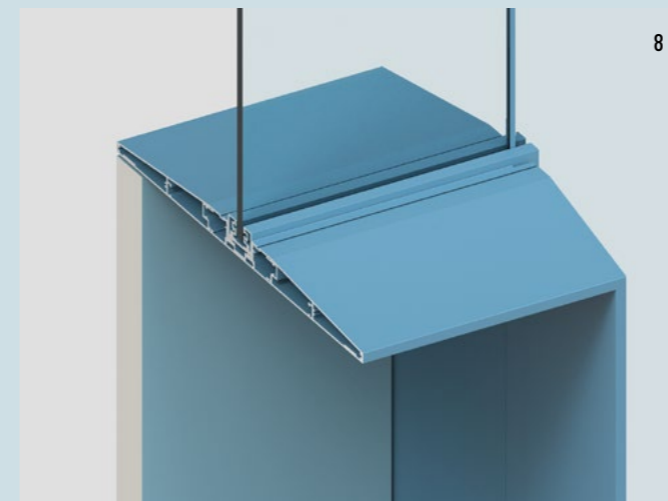
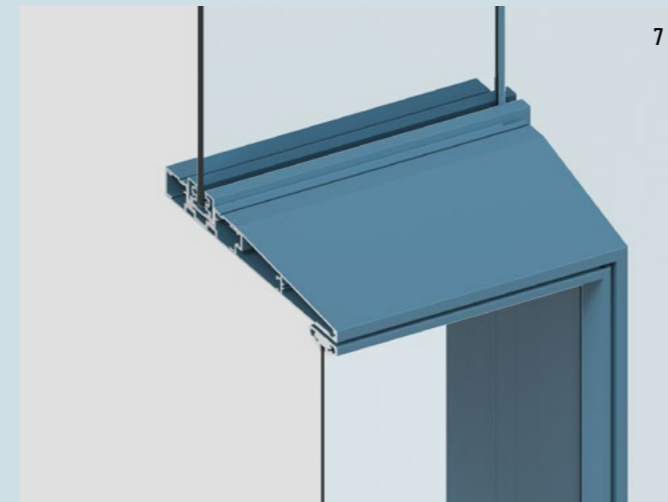
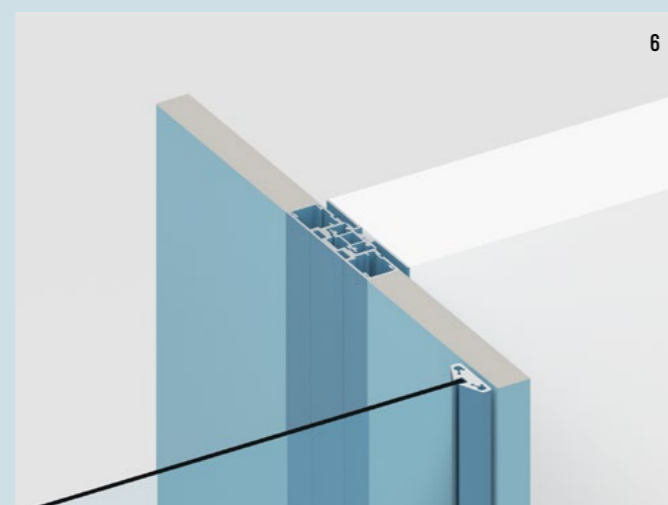
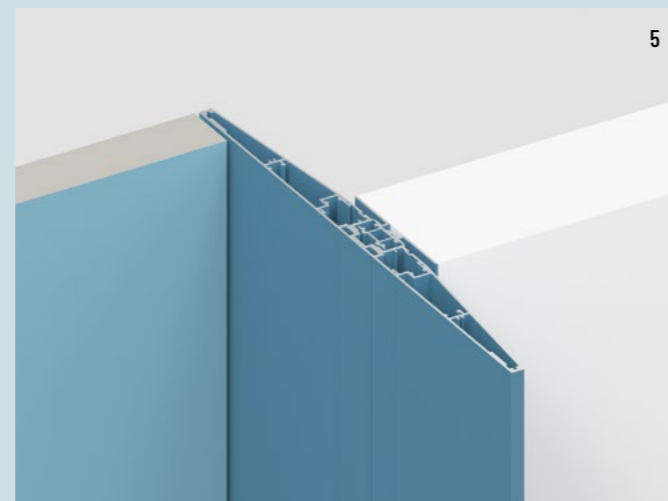
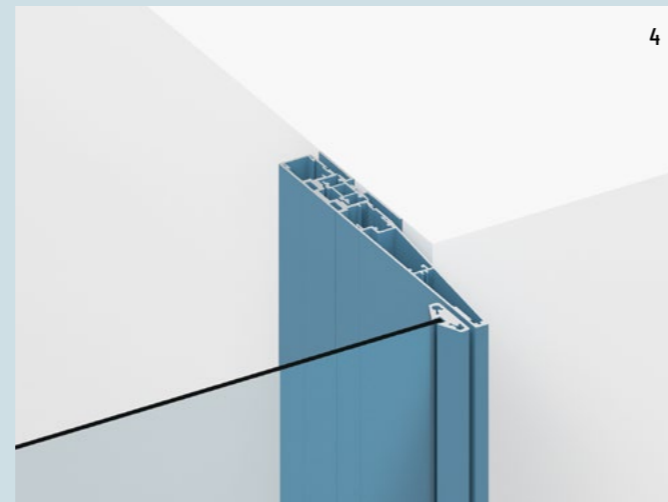
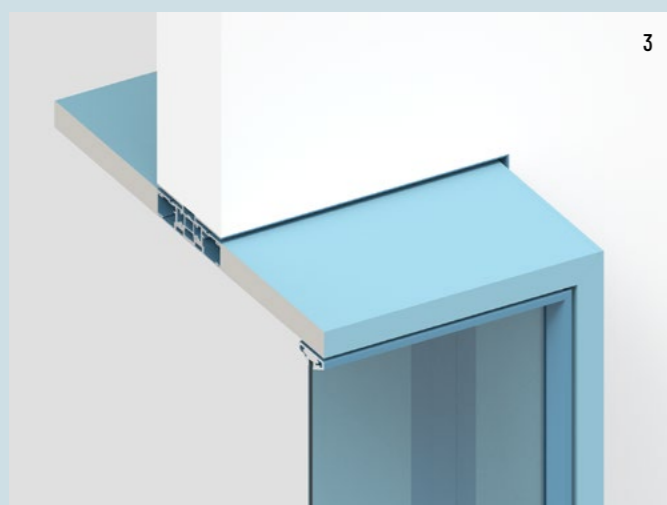

**1. Sezione verticale Stipite portale bilico con porta Entre-deux e ala alluminio, corridoio**  
1. Vertical section Pivoting portal jamb with Entre-deux door and aluminium wing, corridor

**2. Sezione verticale Stipite portale bilico con porta Entre-deux e ali alluminio, parete**  
2. Vertical section Pivoting portal jamb with Entre-deux door and aluminium wings, wall

**3. Sezione verticale Stipite portale bilico con porta Entre-deux e ali legno, parete**  
3. Vertical section Pivoting portal jamb with Entre-deux door and wooden wings, wall

**4. Sezione orizzontale Stipite portale bilico con porta Entre-deux e ala alluminio, corridoio**  
4. Horizontal section Pivoting portal jamb with Entre-deux door and aluminium wing, corridor

**5. Sezione orizzontale Stipite portale bilico con porta Entre-deux e ali alluminio, parete**  
5. Horizontal section Pivoting portal jamb with Entre-deux door and aluminium wings, wall

**6. Sezione orizzontale Stipite portale bilico con porta Entre-deux e ali legno, parete**  
6. Horizontal section Pivoting portal jamb with Entre-deux door and wooden wings, wall

**7. Sezione verticale Stipite portale bilico con porta Entre-deux e ala alluminio, sistema All Ways**  
7. Vertical section Pivoting portal jamb with Entre-deux door and aluminium wing, All Ways system

**8. Sezione verticale Stipite portale bilico con porta Entre-deux e ali alluminio, sistema All Ways**  
8. Vertical section Pivoting portal jamb with Entre-deux door and aluminium wings, All Ways system

**9. Sezione verticale Stipite portale bilico con porta Entre-deux e ali legno, sistema All Ways**  
9. Vertical section Pivoting portal jamb with Entre-deux door and wooden wings, All Ways system

**10. Sezione orizzontale Stipite portale bilico con porta Entre-deux e ala alluminio, sistema All Ways**  
10. Horizontal section Pivoting portal jamb with Entre-deux door and aluminium wing, All Ways system

**11. Sezione orizzontale Stipite portale bilico con porta Entre-deux e ali alluminio, sistema All Ways**  
11. Horizontal section Pivoting portal jamb with Entre-deux door and aluminium wings, All Ways system

**12. Sezione orizzontale Stipite portale bilico con porta Entre-deux e ali legno, sistema All Ways**  
12. Horizontal section Pivoting portal jamb with Entre-deux door and wooden wings, All Ways system



# Bilico senza stipiti

## Pivoting without jamb

La soluzione "bilico senza stipite" permette di realizzare porte minimali che dividono gli spazi architettonici senza alcun elemento aggiunto. I pannelli ruotano sul proprio asse verticale, simmetrico o asimmetrico, diventando essi stessi elementi progettuali architettonici. Il meccanismo utilizzato per questa soluzione prevede un ritorno, l'arresto in posizione di chiusura e la gestione del fine corsa. Inoltre rispetta gli standard per i meccanismi di chiusura EN1154.

The pivoting solution without jamb allows to create minimal doors that divide the architectural spaces without any additional element. The panels rotate on their vertical, symmetrical or asymmetrical axis, becoming themselves architectural design elements. The mechanism used for this solution provides a return, the stop in the closing position and the management of the stroke end. This door is compliant with the EN1154 standard for door closure mechanisms.

### Pannello singolo / Single panel

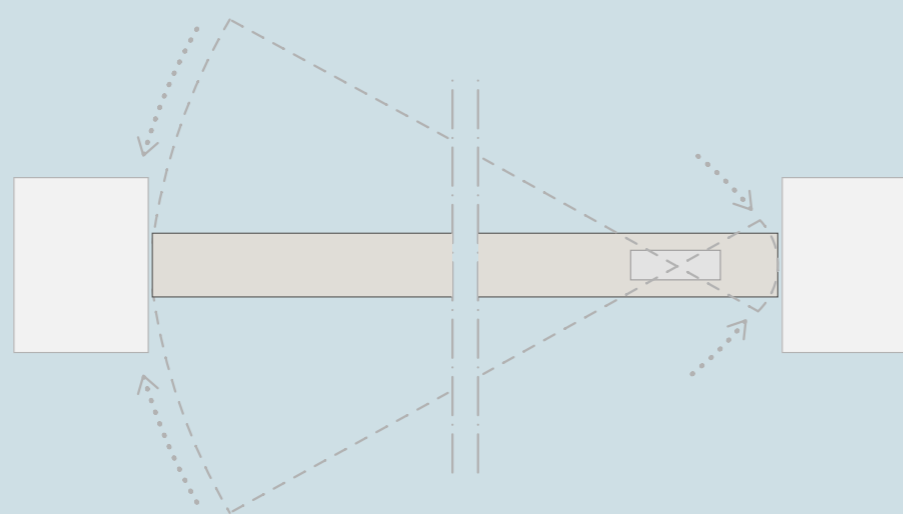
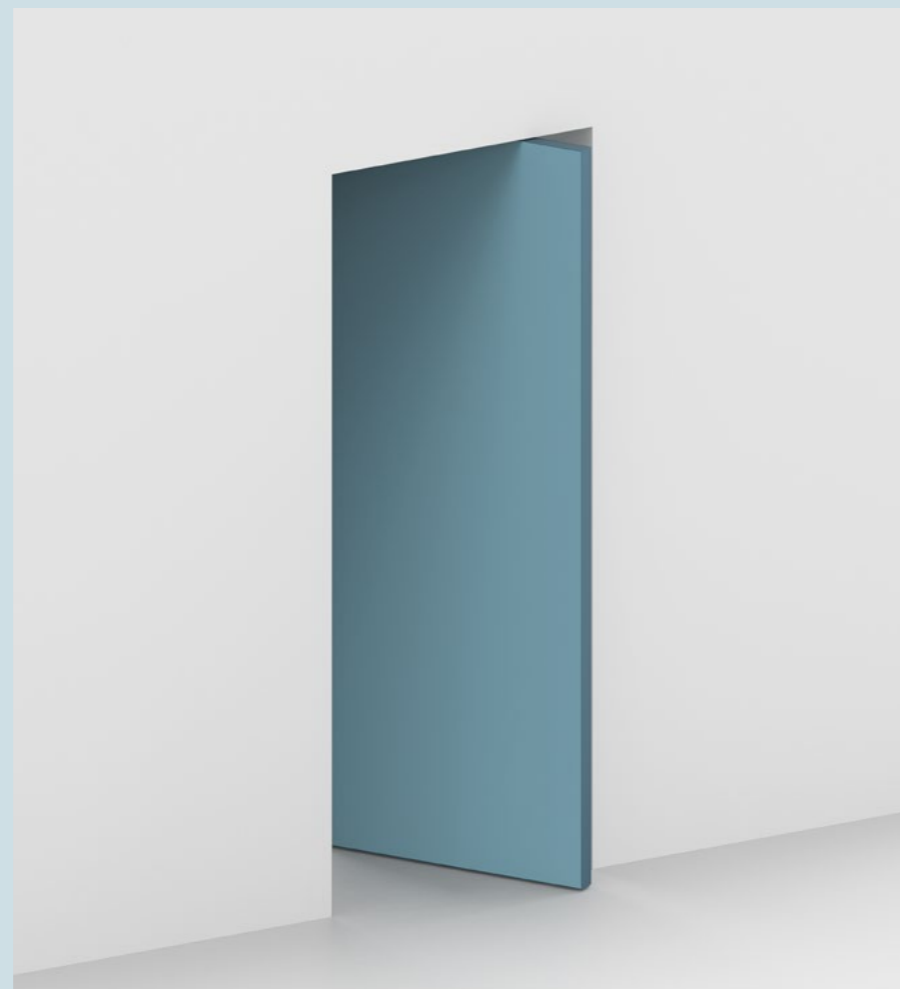

Questa soluzione è dotata di un sistema chiudiporta integrato  
This solution is equipped with an integrated closer system

### Compatibilità / Compatibilities

#### Next

P. 176

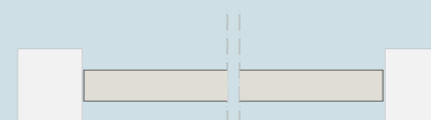

Next pannello 50mm  
Next 50mm panel

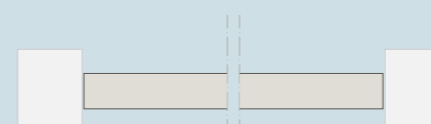

Next pannello 58mm  
Next 58mm panel

#### Suit

P. 177

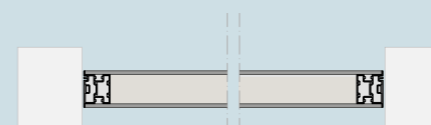

Suit telaio alluminio  
Aluminium frame Suit

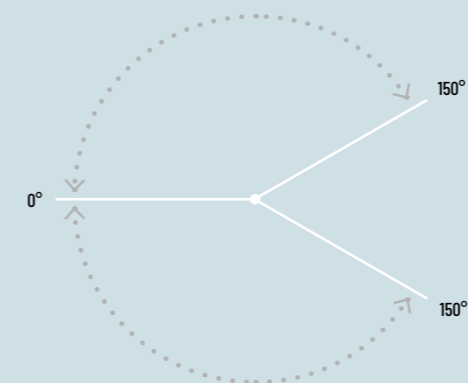

Posizione di arresto  
Holding positions

### Dettagli / Details

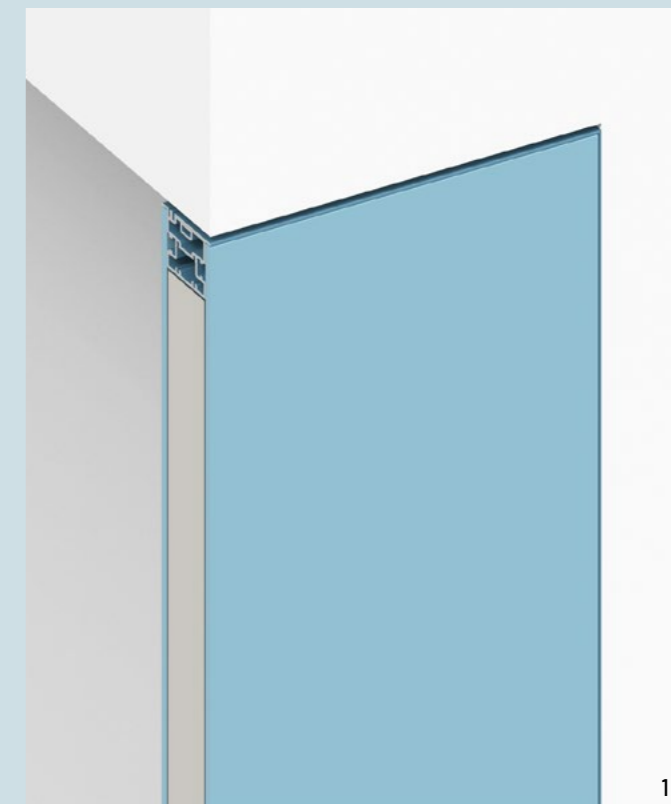

1

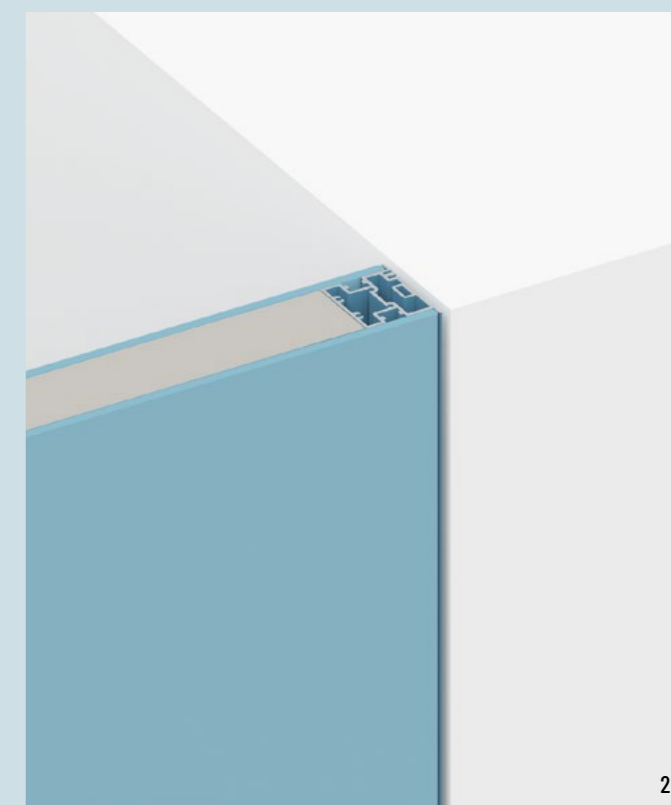

2

1. Sezione verticale Suit pivotante senza stipiti  
1. Vertical section pivoting Suit without jamb

2. Sezione orizzontale Suit pivotante senza stipiti  
2. Horizontal section pivoting Suit without jamb

# Next bilico senza stipiti

## Pivoting Next without jamb

### 1 PORTE SINGOLE STANDARD / STANDARD SINGLE DOORS

Tipo pannello Panel type	Finitura pannello Panel finishing	Spessore pannello Panel thickness	Bilico senza stipiti Pivoting without jamb
Pannello legno Wooden panel	[1] Laccato standard Standard lacquered	50mm	€ 1.750
	58mm	€ 2.050	
Pannello cuoio Leather panel	[2] Cuoio rigenerato Regenerated leather	50mm	€ 2.525

Il telaio porta è disponibile in tutte le finiture alluminio anodizzato o bianco RAL 9003  
Frame door is available in all anodized aluminum finishings or white RAL 9003

### DIMENSIONI STANDARD / STANDARD SIZES

Pannelli standard Standard panels	Foro architettonico Architectural hole
L 700/800/900 x H 2400	L 712/812/912 x H 2422



Pannello Next  
Next panel

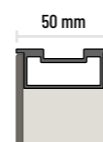

Profilo Next  
pannello cuoio  
Next leather  
panel profile

### 2 DIMENSIONI CUSTOM / CUSTOM SIZES

Tipo pannello Panel type	Dimensioni pannello: Panel dimension:	L < 1200
Pannello legno Wooden panel	50mm	H < 2400 + € 300
		H < 2700 + € 450
	58mm	H < 2700 + € 450
		H < 3000 + € 600
Pannello cuoio Leather panel	50mm	H < 2400 + € 300
		H < 2700 + € 450
	58mm	H < 2700 + € 450
		H < 3000 + € 600

Il perno di rotazione è posizionato a:  
• 65mm dal bordo del foro architettonico per pannelli con L < 900  
• 150mm dal bordo del foro architettonico per pannelli con L > 900  
The pivot is positioned at:  
• 65mm from the architectural hole edge for panel L < 900  
• 150mm from the architectural hole edge for panel L > 900

### 3 FINITURE / FINISHINGS

Tipo pannello Panel type	Finitura Finishing	P. 30
Pannello legno Wooden panel	Con fondo / Con fondo	- € 120
	Laccato custom RAL Custom RAL lacquered	+ € 200
	Essenza legno Wooden essence	+ € 270
Pannello cuoio Leather panel	Cuoio Leather	+ € 300



[1]

Pannello legno  
Wooden panel



[2]

Pannello cuoio  
Leather panel

### 4 MANIGLIE / HANDLES

Tipo pannello Panel type	Maniglia Handle	Solo maniglia Only handle
Tutti i pannelli All panels	Piave	+ € 100
	Loira tonda	+ € 150
	Ticino 400mm	+ € 150
Ticino 1600mm		+ € 250
	Arno 600mm	+ € 100
	Arno 1600mm	+ € 150

Per questo pannello è possibile ordinare 0 o 1 coppia di maniglie  
For this panel it is possible to order 0 or 1 pair of handles

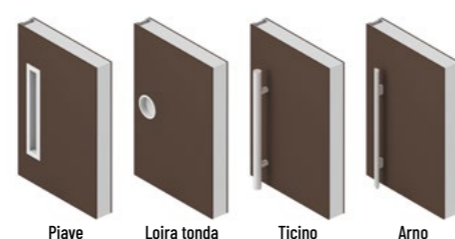

### CODICI PORTE / DOORS CODES

Tipo pannello Panel type	Bilico senza stipiti Pivoting without jamb
[1] 50mm	NTCQ001
58mm	NTCQ002
[2] 50mm	NTCQ003

### CODICI MANIGLIE / HANDLES CODES

Maniglia Handle	Solo maniglia Only handle
Piave	QX
Loira tonda*	V1
Ticino 400mm	T1
Ticino 1600mm	T
Arno 600mm	S
Arno 1600mm	S2

\* disponibile in finitura cromo satinato o lucido  
\* available in satin or polished chrome finishing

# Suit bilico senza stipiti

## Pivoting Suit without jamb

### 1 PORTE SINGOLE STANDARD / STANDARD SINGLE DOORS

Tipo pannello Panel type	Finitura pannello Panel finishing	Finitura telaio porta Frame door finishing	Bilico senza stipiti Pivoting without jamb
Telaio alluminio Aluminium frame	[2] Predisposto per lastra da 6mm* Designed for 6mm boards*	Alluminio anodizzato o bianco RAL 9003 Anodized aluminum or White RAL 9003	€ 1.690

\*Peso massimo totale delle lastre: 130kg  
\*Total maximum plates weight: 130kg

### DIMENSIONI STANDARD / STANDARD SIZES

Pannelli standard Standard panels	Foro architettonico Architectural hole
L 700/800/900 x H 2400	L 712/812/912 x H 2422

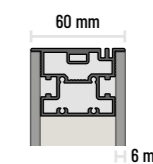

Profilo Suit  
telaio alluminio  
Profilo Suit  
telaio alluminio

### 2 DIMENSIONI CUSTOM / CUSTOM SIZES

Tipo pannello Panel type	Dimensioni pannello: Panel dimension:	L < 1200
Telaio alluminio Aluminium frame	H < 2400*	+ € 150
	H < 2700	+ € 200
	H < 3000	+ € 250

\*per H < 2400 peso massimo totale delle lastre: 100kg  
\*for H < 2400 total maximum plates weight: 100kg

Il perno di rotazione è posizionato a:  
• 65mm dal bordo del foro architettonico per pannelli con L < 900  
• 150mm dal bordo del foro architettonico per pannelli con L > 900  
The pivot is positioned at:  
• 65mm from the architectural hole edge for panel L < 900  
• 150mm from the architectural hole edge for panel L > 900

### 3 FINITURE LASTRE / BOARDS FINISHINGS

Tipo pannello Panel type	Lastra 6mm in finitura** 6mm board finishing**	P. 30
Telaio alluminio Aluminium frame	Con fondo / Con fondo	+ 15%
	Laccato standard Standard lacquered	+ 25%
	Laccato custom RAL Custom RAL lacquered	+ 35%
	Essenza legno Wooden essence	+ 47%
	Vetro opaco Opaque glass	Cat. C + 30% Cat. D + 35%
Cuoio Leather	+ 50%	

\*\*Selezionare una lastra per ogni faccia della porta. Al momento dell'ordine specificare quale lastra debba essere posizionata sulla faccia anteriore e quale sulla faccia posteriore. / \*\*Select a board for each face of the door. When ordering, specify which board have to be positioned on the front face and which on the back face.

### 4 MANIGLIE / HANDLES

Tipo pannello Panel type	Maniglia Handle	Solo maniglia Only handle
Telaio alluminio Aluminium frame	Piave	+ € 100
	Loira tonda	+ € 150
	Ticino 400mm	+ € 150
	Ticino 1600mm	+ € 250
	Arno 600mm	+ € 100
	Arno 1600mm	+ € 150

Per questo pannello è possibile ordinare 0 o 1 coppia di maniglie  
For this panel it is possible to order 0 or 1 pair of handles



### CODICI PORTE / DOORS CODES

Tipo pannello Panel type	Bilico senza stipiti Pivoting without jamb
[2]	STCQ002

### CODICI MANIGLIE / HANDLES CODES

Maniglia Handle	Solo maniglia Only handle
Piave	QX
Loira tonda*	V1
Ticino 400mm	T1
Ticino 1600mm	T
Arno 600mm	S
Arno 1600mm	S2

\* disponibile in finitura cromo satinato o lucido  
\* available in satin or polished chrome finishing

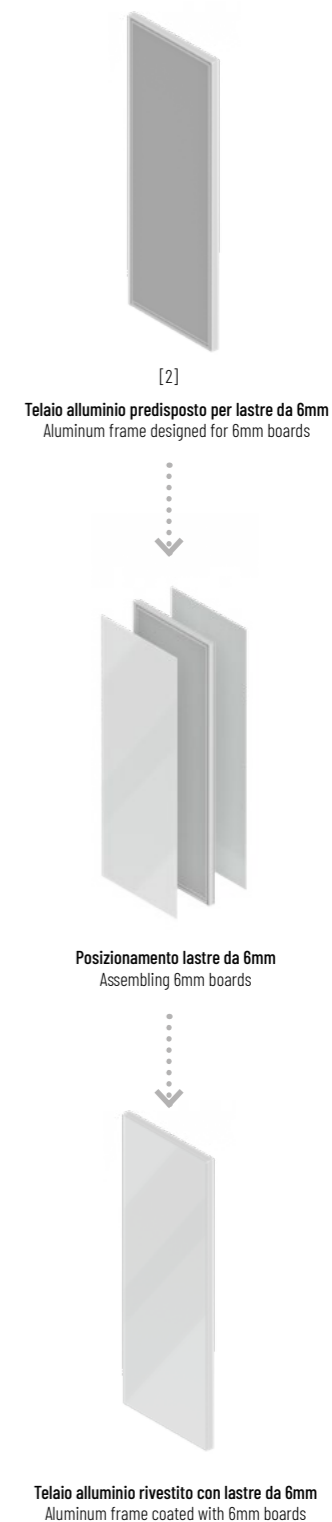

Telaio alluminio rivestito con lastre da 6mm  
Aluminium frame coated with 6mm boards

Tavoli  
Table

Librerie  
Bookcase

Cabine armadio  
Walk-in closet

Boiserie  
Boiserie

Pareti divisorie  
Partition wall

Pan. scorrevoli o girevoli  
Sliding or pivoting panels

Porte a scomparsa  
Pocket door

Porte senza falso telaio  
Door w/o basic door frame

Porte filomuro  
Flush door

Porte effetto filomuro  
Flush-effect door

Porte battenti con cornice  
Hinged door and frame

Informazioni generali  
General informations



# PORTE A SCOMPARSA POCKET DOOR

La porta "a scomparsa" è la porta ideale per chi ha spazi ridotti, scomparendo nello spessore della parete. Una soluzione che recupera lo spazio che è solitamente occupato dal raggio di apertura della tradizionale porta a battente. Può essere realizzata integrando i cassonetti metallici in commercio o con il binario Albed con applicazione del Kit-pocket.

The "pocket" door is ideal for anyone with limited space, because it disappears into the thickness of the wall. This solution frees up space that is normally taken up by the opening radius of a traditional hinged door. It can be made with off-the-shelf metallic counterframes or by using the Albed rail with the application of the Kit-pocket.

## Sistema prodotto / Product system

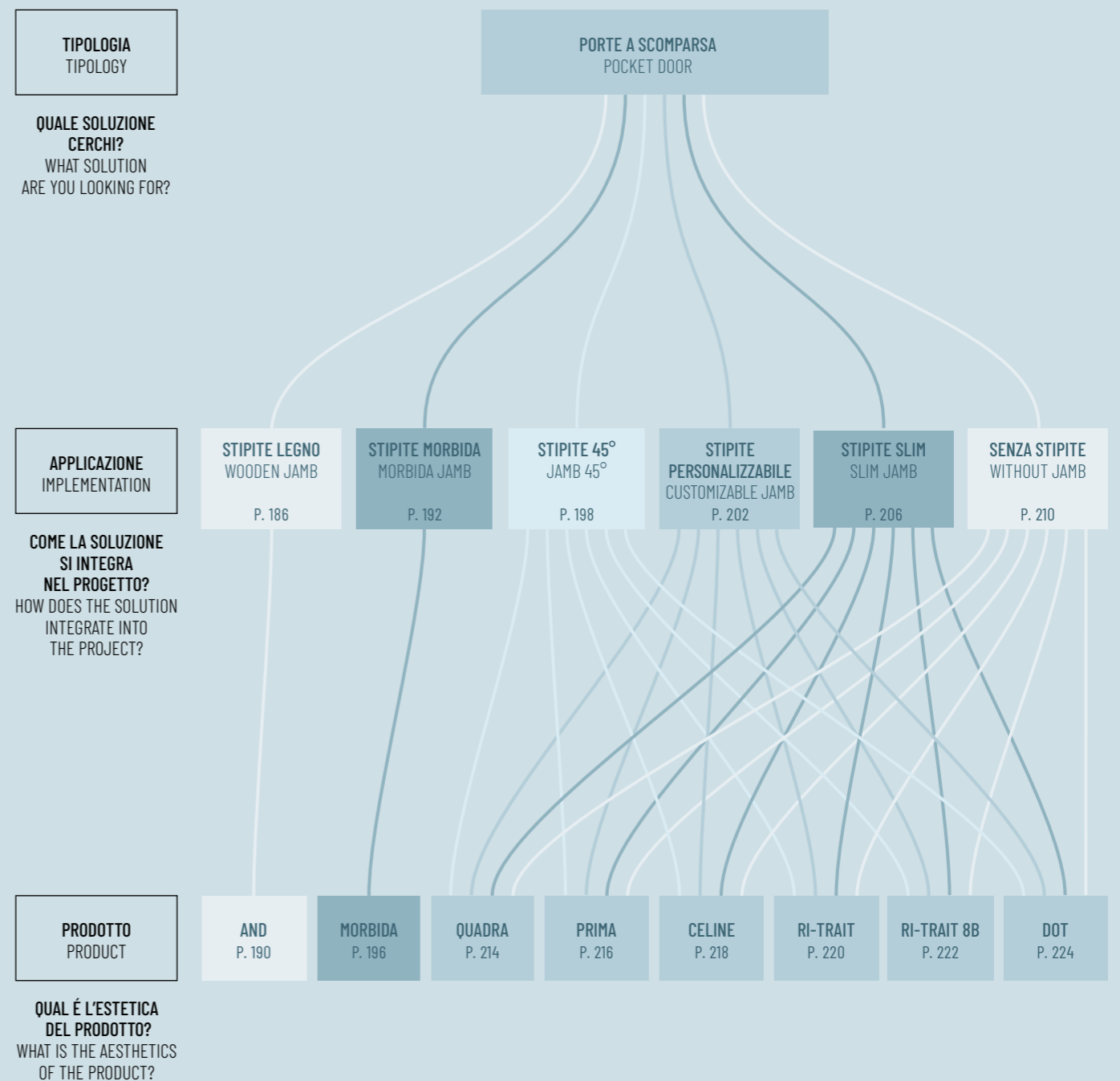

Tavoli  
Table

Librerie  
Bookcase

Cabine armadio  
Walk-in closet

Boiserie  
Boiserie

Pareti divisorie  
Partition wall

Pan. scorrevoli o girevoli  
Sliding or pivoting panels

Porte a scomparsa  
Pocket door

Porte senza falso telaio  
Door w/o basic door frame

Porte filomuro  
Flush door

Porte effetto filomuro  
Flush-effect door

Porte battenti con cornice  
Hinged door and frame

Informazioni generali  
General informations

# Stipite legno per porte a scomparsa

## Wooden jamb for pocket door

### Porta singola / Single door

Lo stipite in legno è la soluzione tradizionale per eccellenza del sistema porta.

The wooden jamb is the traditional solution par excellence in the door system.



Porta singola  
Single door

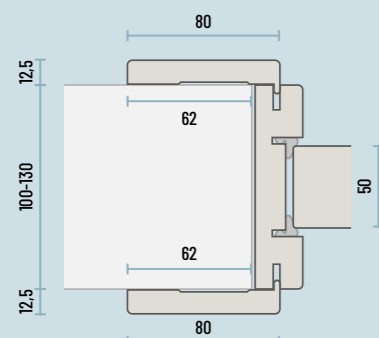

Dimensioni (mm) stipite legno per porte a scomparsa, lato di battuta  
Dimensions (mm) wooden jamb for pocket door, stop side

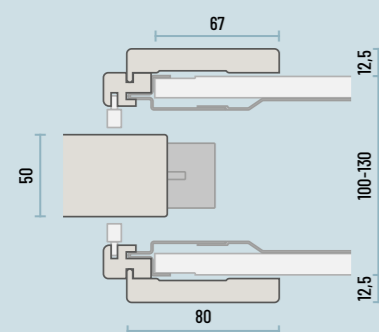

Dimensioni (mm) stipite legno per porte a scomparsa, lato di scorrimento  
Dimensions (mm) wooden jamb for pocket door, sliding side.

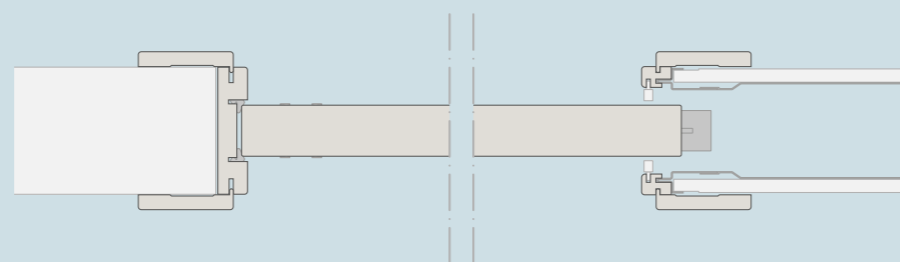

### Porta doppia / Double door



Porta doppia  
Double door

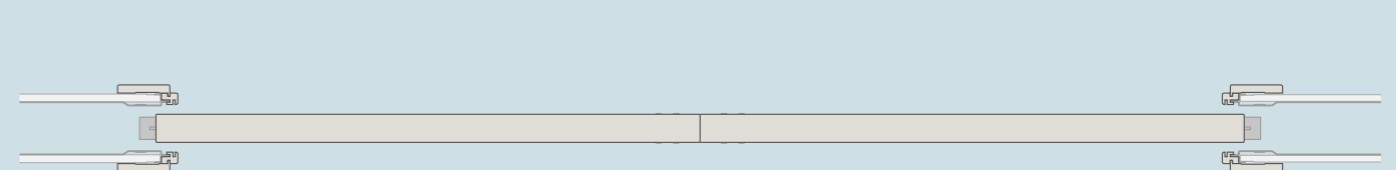

# Stipite legno per a scomparsa

## Wooden jamb for pocket door

### Compatibilità / Compatibilities

### Dettagli / Details

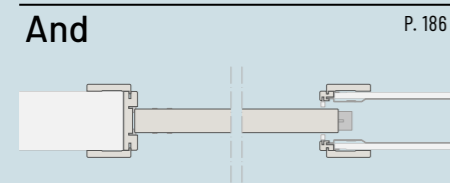

**And a scomparsa**  
And pocket door



**1. Sezione verticale Stipite legno con And a scomparsa**  
1. Vertical section Wooden jamb with And pocket door

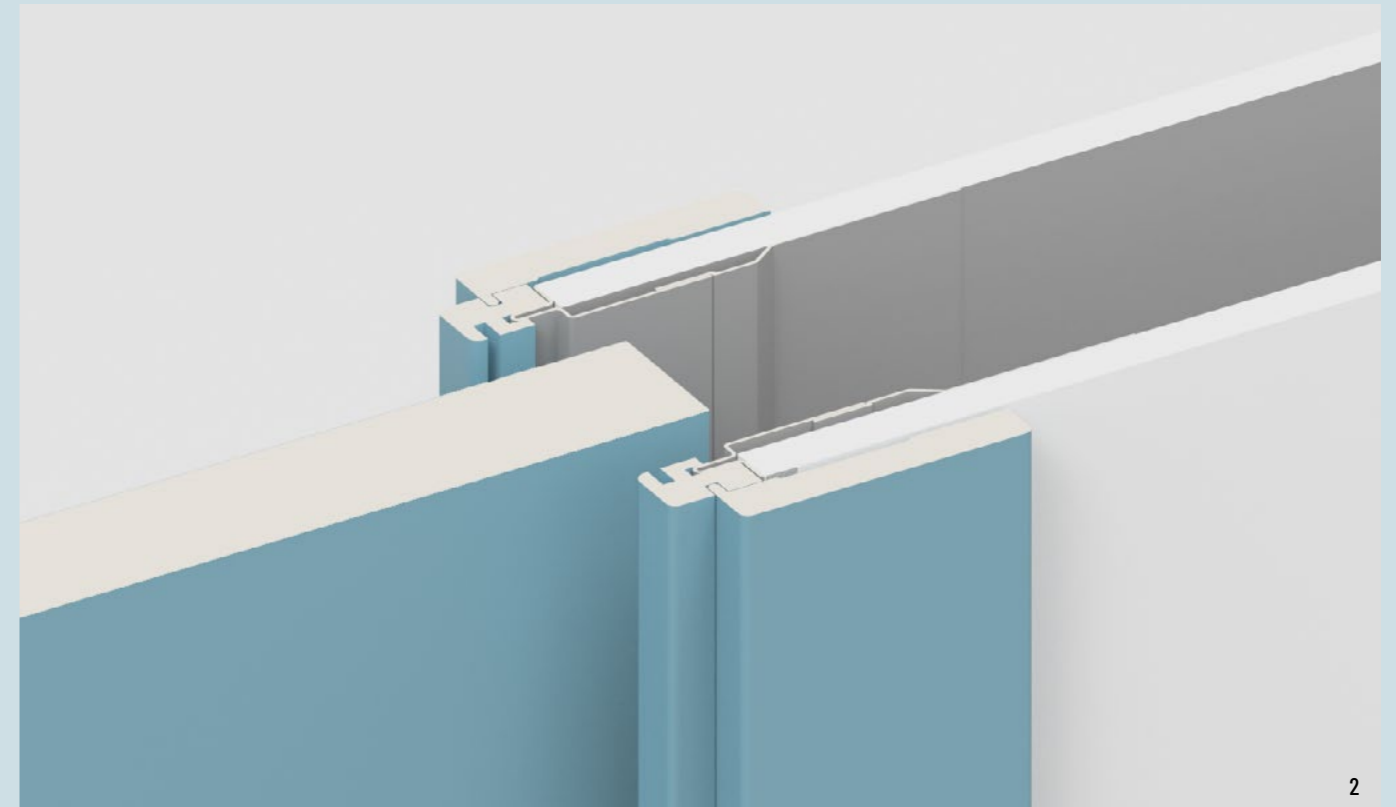

**2. Sezione orizzontale Stipite legno con And a scomparsa, lato di scorrimento**  
2. Horizontal section Wooden jamb with And pocket door, sliding side

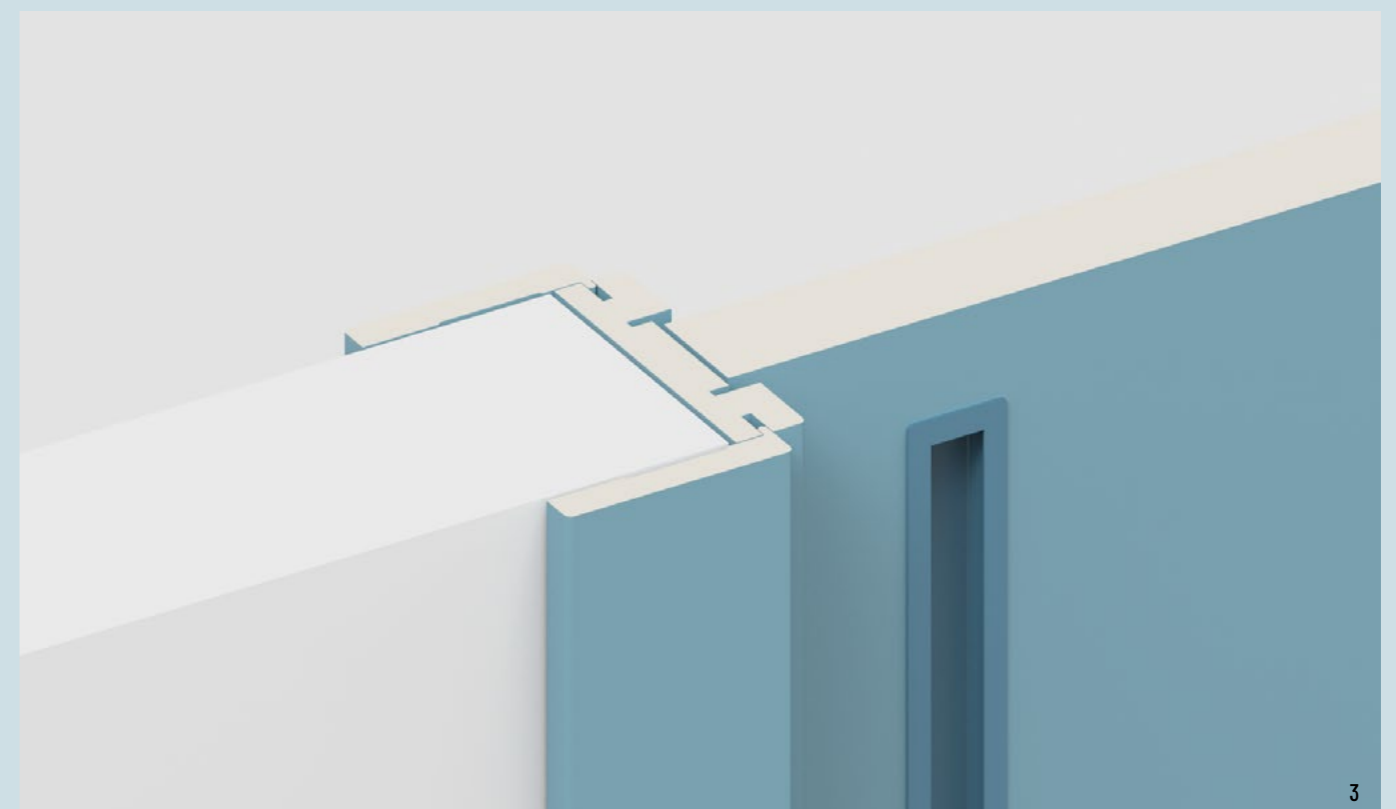

**3. Sezione orizzontale Stipite legno con And a scomparsa, lato battuta**  
3. Horizontal section Wooden jamb with And pocket door, stop side

# And a scomparsa

## And pocket door

### 1 PORTE SINGOLE STANDARD / STANDARD SINGLE DOORS

Tipo pannello Panel type	Finitura base Base finishing	Stipite legno Wooden jamb
Pannello legno Wooden panel	Laccato standard Standard lacquered	[1] € 950

### DIMENSIONI STANDARD / STANDARD SIZES

Porta singola Single door	Pannelli standard Standard panels	Luce controtelaio Counterframe clearance
Stipite legno Wooden jamb	L 633/733/833/933/ 1033 x H 2109	L 650/750/850/950/ 1050 ±10 x H 2150 ±10

Al momento dell'ordine specificare il senso di apertura:  
sinistra o destra.  
When ordering, specify the opening side of the door: left or right.

### 2 DIMENSIONI CUSTOM / CUSTOM SIZES

Tipo pannello Panel type	H luce controtelaio: H counterframe clearance:	
Pannello legno Wooden panel	H < 2400 H 2400 - H 2700	+ € 140 + € 350

Per qualsiasi larghezza luce controtelaio custom:  
\* fino a L 1050 ±10 porta singola  
\* fino a L 2050 ±10 porta doppia  
For any custom counterframe clearance width:  
\* up to L 1050 ±10 single door  
\* up to L 1050 ±10 double door

### 3 FINITURE / FINISHINGS

Tipo pannello Panel type	Finitura Finishing	P. 30
Pannello legno Wooden panel	Laccato custom RAL Custom RAL lacquered	+ € 190

### 4 PERSONALIZZAZIONI / PERSONALIZATION

Tipo pannello Panel type	Pantografatura Grooving	
Pannello legno Wooden panel	1 riquadro / 1 square [2] 2 riquadri / 2 squares [3] 3 riquadri / 3 squares [4]	+ € 250

### 5 PORTA DOPPIA / PORTA DOPPIA

Tipo pannello Panel type	Porta doppia Double door	
Pannello legno Wooden panel	Porta doppia Double door	+ 90%

### DIMENSIONI STANDARD / STANDARD SIZES

Porta doppia Double door	Pannelli standard Standard panels	Luce controtelaio Counterframe clearance
Stipite legno Wooden jamb	L 633/733/833/933/ 1033 x H 2109	L 1250/1450/1650/1850/ 2050 ±10 x H 2150 ±10

### 6 MANIGLIA E SERRATURA / HANDLES AND LOCK

Tipo pannello Panel type	Maniglia Handle	Solo maniglia Only handle	Chiave Patent Patent key	Nottolino Latch free/busy
Pannello legno Wooden panel	Piave Loira tonda Loira quadrata	+ € 100 + € 150 + € 150	+ € 200 + € 250 + € 250	+ € 200 + € 250 + € 250

Per porta doppia ordinare due elementi / For double door order two elements

### 7 ACCESSORI STIPITE / JAMBS ACCESSORIES

Stipite Jamb	Accessorio stipite Jamb accessory	Pagina listino Page price book
Stipite legno Wooden jamb	Aggiustaggi / Adjustments	P. 231

Aggiustaggi sono necessari quando i muri hanno un range di spessore diverso da 95mm-130mm  
Adjustments are necessary when the walls have a thickness range different from 95mm-130mm

### 8 CONTROTELAI PER PORTE A SCOMPARSA / COUNTERFRAMES FOR POCKET DOOR

Tipo controtelaio Counterframe type	Pagina listino Page price book
per muratura for wall	P. 227
per cartongesso for plasterboard	P. 228

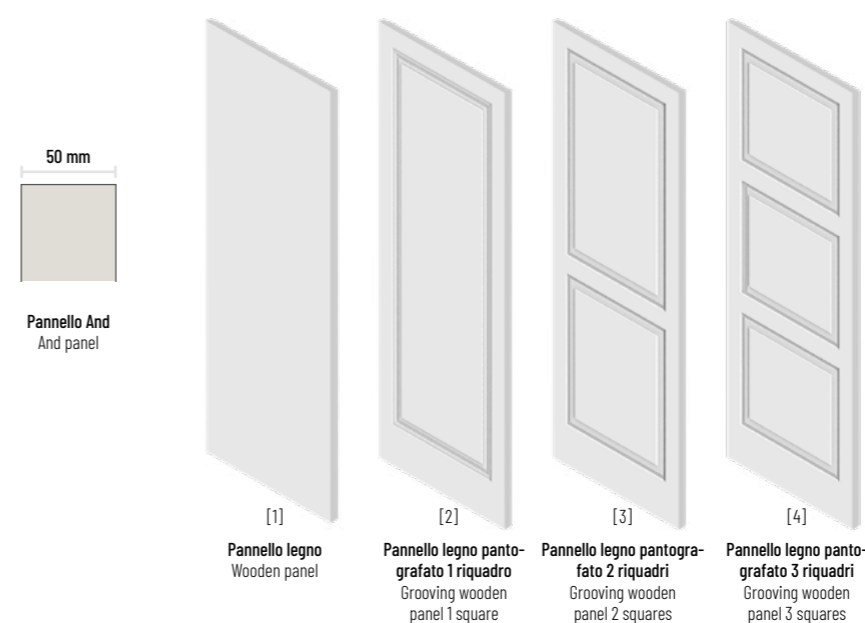

### CODICI PORTE / DOORS CODES

Tipo pannello Panel type	Stipite legno / Wooden jamb	
	Porta singola Single door	Porta doppia Double door
[1]	AN-SC10	AN-SC20
[2]	AN-SC12	AN-SC22
[3]	AN-SC14	AN-SC24
[4]	AN-SC16	AN-SC26

### Maniglie per porte a scomparsa Pocket door handles

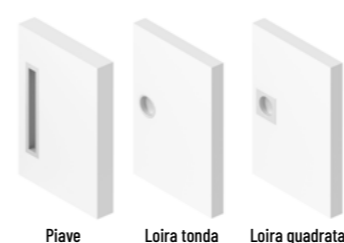

### CODICI MANIGLIE / HANDLES CODES

Maniglia Handle	Solo maniglia Only handle	Chiave Patent Patent key	Nottolino Latch free/busy
Piave	Q	Q1	Q2
Loira tonda*	V1	V2	V3
Loira quadrata*	V4	V5	V6

\* disponibile in finitura cromo satinato o lucido  
\* available in satin or polished chrome finishing



# Stipite Morbida per porte a scomparsa

## Morbida jamb for pocket door

Lo stipite Morbida raccorda la superficie del pannello sopra luce a quella della parete per un effetto unico. Il traverso orizzontale può essere configurato in diverse altezze. La continuità tra le superfici è ancora maggiore con i sistemi boiserie Albed.

The Morbida jamb connects the surface of the transom panel to that of the wall for a unique effect. The transom can be configured in different heights. The continuity between surfaces is even greater with Albed boiserie systems.

### Porta singola / Single door

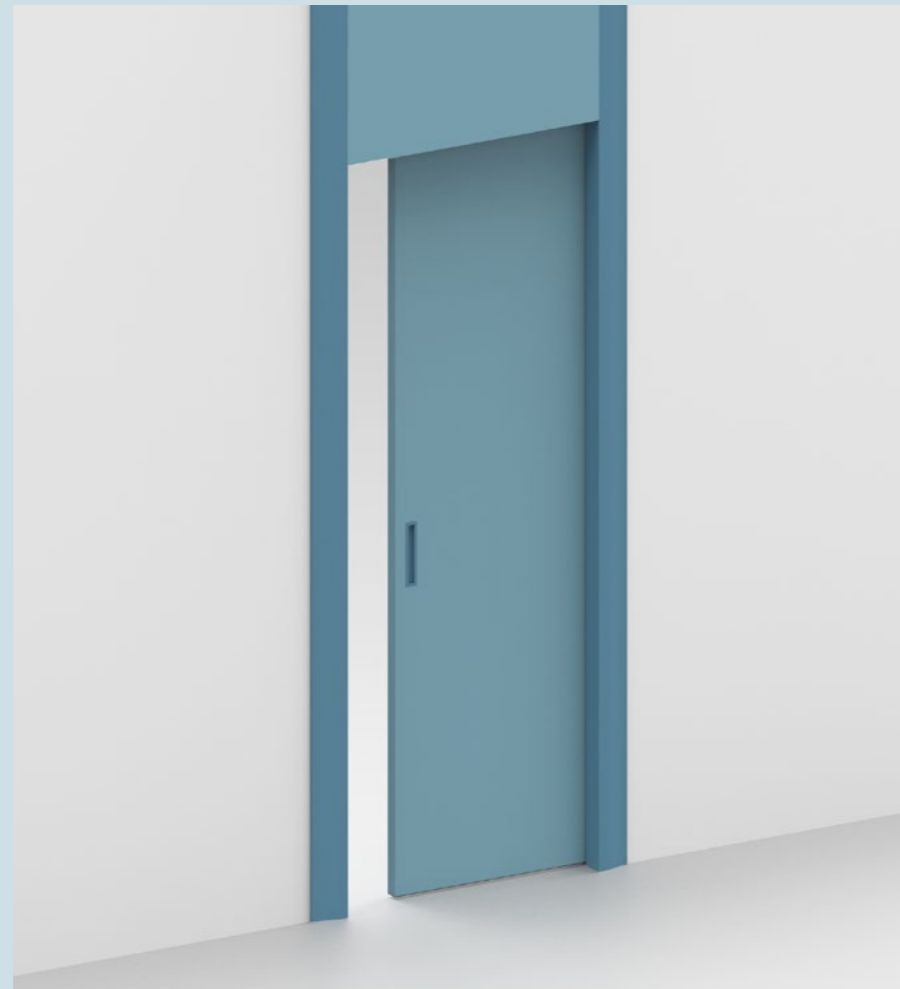

### Porta doppia / Double door

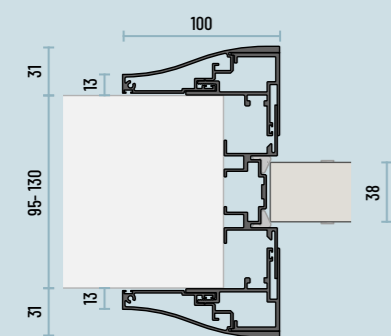

Dimensioni (mm) stipite Morbida per porte a scomparsa, lato di battuta  
Dimensions (mm) Morbida jamb for pocket door, stop side

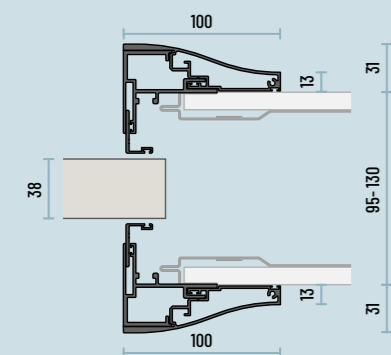

Dimensioni (mm) stipite Morbida per porte a scomparsa, lato di scorrimento  
Dimensions (mm) Morbida jamb for pocket door, sliding side

#### Porta singola Single door

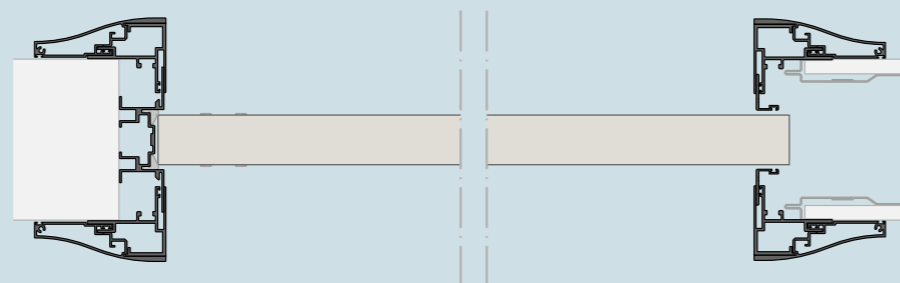

#### Porta doppia Double door

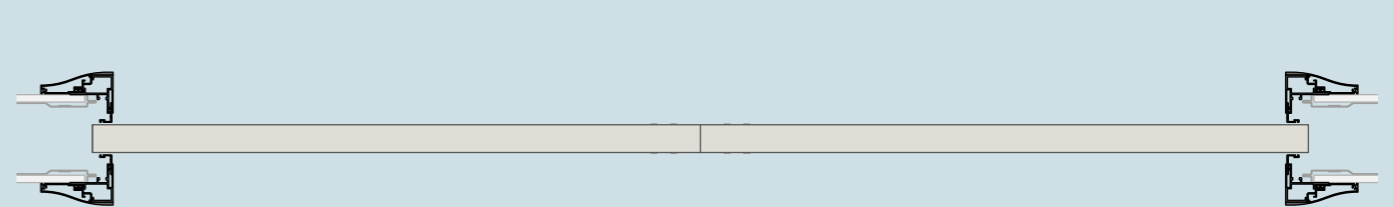

# Stipite Morbida per porte a scomparsa

## Morbida jamb for pocket door

### Compatibilità / Compatibilities

### Dettagli / Details

#### Morbida P. 196

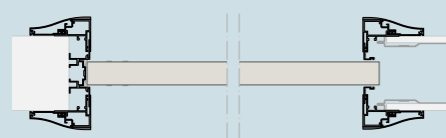

#### Morbida pannello a scomparsa Morbida panel pocket door

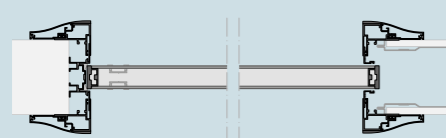

#### Morbida doppio vetro a scomparsa Morbida double glass pocket door

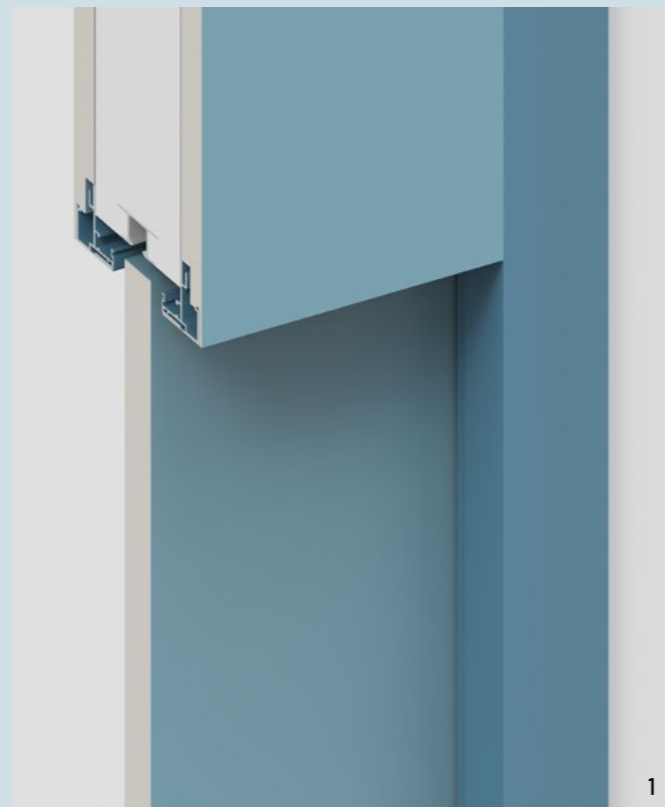

**1. Sezione verticale Stipite Morbida con Morbida a scomparsa**  
1. Vertical section Morbida jamb with Morbida pocket door

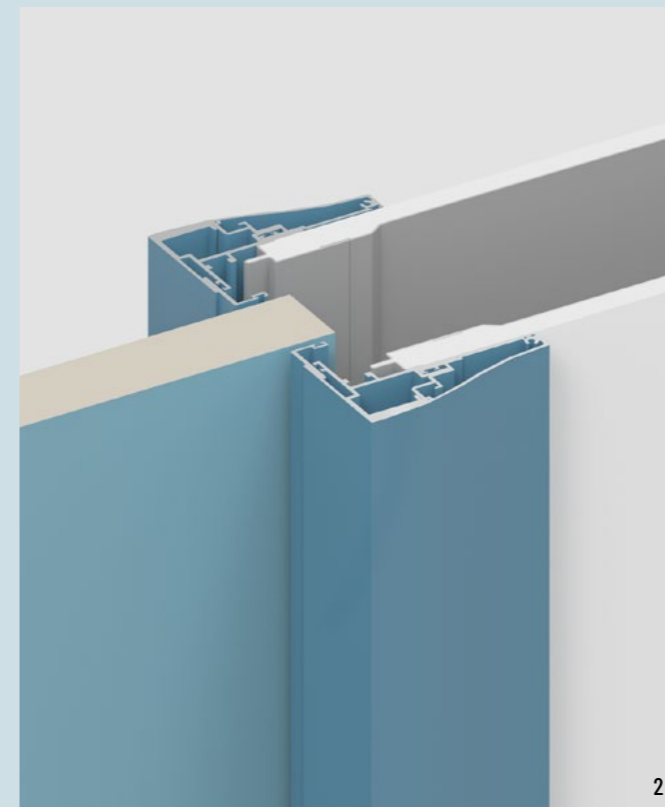

**2. Sezione orizzontale porta Morbida a scomparsa, lato di scorrimento**  
2. Horizontal section Morbida pocket door, sliding side

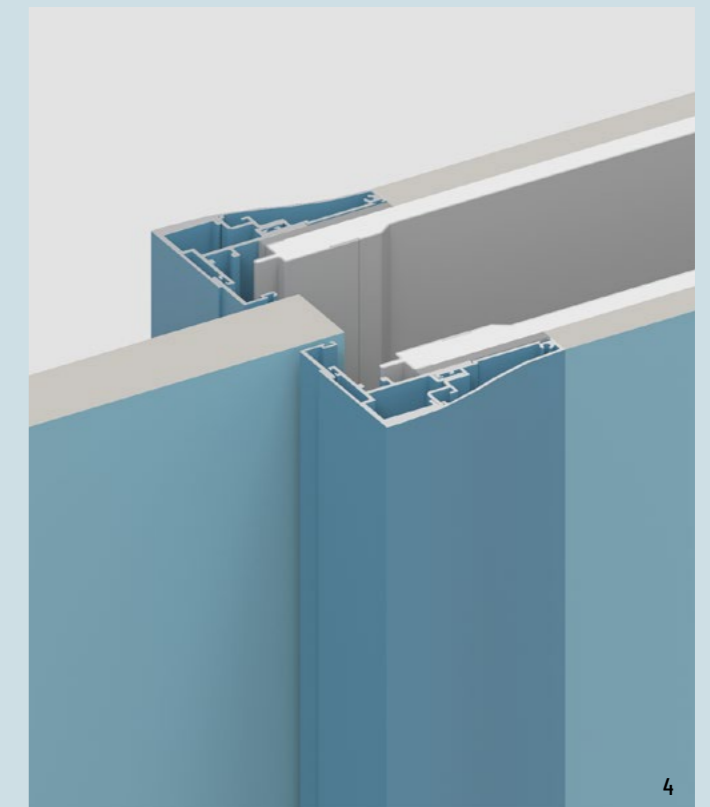

**4. Sezione orizzontale porta Morbida a scomparsa con pannelli Boiserie a incollaggio, lato di scorrimento / 4. Horizontal section Morbida pocket door with Boiserie gluing panels, sliding side**

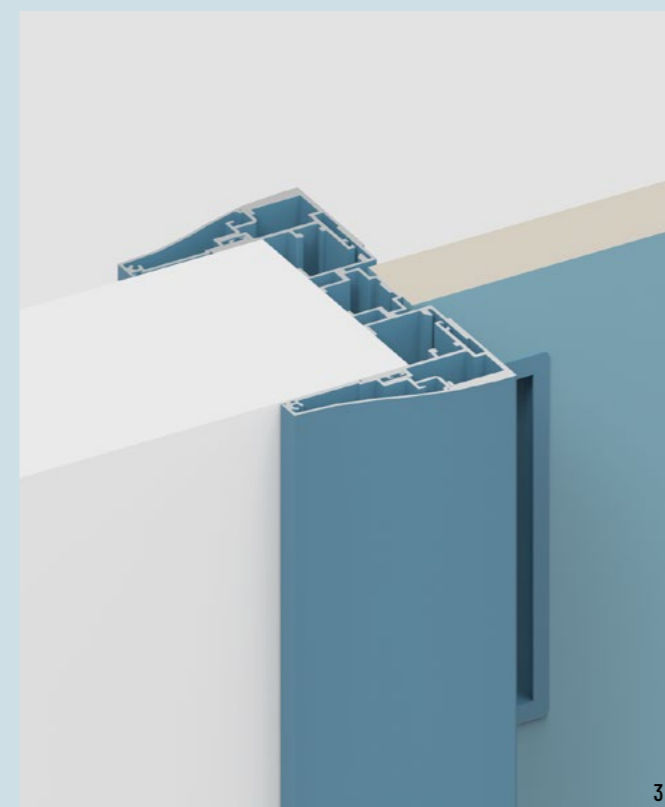

**3. Sezione orizzontale porta Morbida a scomparsa, lato battuta**  
3. Horizontal section Morbida pocket door, stop side



**5. Sezione orizzontale porta Morbida a scomparsa con pannelli Boiserie a incollaggio, lato di battuta**  
5. Horizontal section Morbida pocket door with Boiserie gluing panels, stop side

# Morbida a scomparsa

## Morbida pocket door

### 1 PORTE SINGOLE STANDARD / STANDARD SINGLE DOORS

Tipo pannello Panel type	Finitura pannello Panel finishing	Finitura stipite e telaio Jamb and frame finishing	Altezza pannello superiore Upper panel height	Stipite Morbida* Morbida jamb*
Pannello legno Wooden panel	[1] Laccato standard Standard lacquered	Finitura alluminio anodizzato o verniciato Bianco Ral 9003 Anodized aluminium finishing or painted White Ral 9003	H100 H100	€ 1.540
Doppio vetro Double Glass	[5] Vetro opaco Cat. C Opaque glass Cat.C		H100 H100	€ 2.090
Pannello cuoio Leather panel	[6] Cuoio Leather		H100 H100	€ 2.315

\*\* per versione con Stipite 45° posteriore - € 350 / for version with Jamb 45° on the back - € 350

### DIMENSIONI STANDARD / STANDARD SIZES

Porta singola Single door	Pannelli standard Standard panels	Luce controtelaio Counterframe clearance
Stipite Morbida Morbida jamb	L 633/733/833/933/ 1033 x H 2109	L 650/750/850/950/ 1050 ±10 x H 2150 ±10

Al momento dell'ordine specificare il senso di apertura:  
sinistra o destra.  
When ordering, specify the opening side of the door: left or right.

### 2 DIMENSIONI CUSTOM / CUSTOM SIZES

Tipo pannello Panel type	H luce controtelaio: H counterframe clearance:	
Pannello legno Wooden panel	H < 2700	+ € 450
Doppio vetro Double glass	H < 2700	+ € 600
Pannello cuoio Leather panel	H < 2700	+ € 600

Per qualsiasi larghezza luce controtelaio custom:  
\* fino a L 1050 ±10 porta singola  
\* fino a L 2050 ±10 porta doppia  
For any custom counterframe clearance width:  
\* up to L 1050 ±10 single door  
\* up to L 1050 ±10 double door

### 3 FINITURE / FINISHINGS

Tipo elemento Element type	Finitura Finishing	
Pannello legno Wooden panel	Essenza legno / Wood essence	+ € 270
	Laccato custom RAL / Custom RAL lacquered	+ € 200
Doppio vetro Double Glass	Vetro opaco Cat. D / Opaque glass Cat. D	+ 10%
	Vetro traslucido / Translucent glass	+ € 150
Coprifilo / Lists	Custom Ral / Custom Ral	+ € 190
Stipite / Jamb	Custom Ral / Custom Ral	+ € 400

Il pannello superiore avrà la stessa finitura del pannello porta. Nel caso di porte  
doppio vetro traslucido, specificare una finitura indipendente per il pannello  
superiore / The upper panel will have the same finish as the door panel. In the case of  
translucent double glass door, specify an independent finish for the upper panel.

### 4 PERSONALIZZAZIONE PANNELLO SUPERIORE PER UN LATO UPPER PANEL PERSONALIZATION FOR ONE SIDE

Tipo pannello Panel type	Pannello superiore: Upper panel:	
Pannello legno Wooden panel	H 300	+ € 100
	H 600	+ € 150
	H > 900	+ € 300
Doppio vetro Double Glass	H 300	+ € 100
	H 600	+ € 150
	H > 900	+ € 300
Pannello cuoio Leather panel	H 300	+ € 100
	H 600	+ € 150
	H > 900	+ € 300

### 5 PERSONALIZZAZIONI PANNELLO / PANEL PERSONALIZATIONS

Tipo pannello Panel type	Pantografatura Grooving	
Pannello legno Wooden panel	1 riquadro / 1 square [2]	+ € 250
	2 riquadri / 2 squares [3]	+ € 250
	3 riquadri / 3 squares [4]	+ € 250
Tipo pannello Panel type	Aggiunta di telaio pannello Add panel frame	
Pannello legno Wooden panel	Finitura alluminio anodizzato o RAL 9003 Anodized aluminum finishing or RAL 9003	+ € 380
	Finitura custom RAL / Custom RAL finishing	+ € 670

### 6 PORTA DOPPIA / PORTA DOPPIA

Tipo pannello Panel type	Porta doppia Double door	
Tutti i pannelli All panels	Porta doppia Double door	+ 90%

### DIMENSIONI STANDARD / STANDARD SIZES

Porta doppia Double door	Pannelli standard Standard panels	Luce controtelaio Counterframe clearance
Stipite Morbida Morbida jamb	L 633/733/833/933/ 1033 x H 2109	L 1250/1450/1650/1850/ 2050 ±10 x H 2150 ±10

### 7 MANIGLIA E SERRATURA / HANDLES AND LOCK

Tipo pannello Panel type	Maniglia Handle	Solo maniglia Only handle	Chiave Patent Patent key	Nottolino Latch free/busy
Pannello legno Wooden panel	Piave	+ € 100	+ € 200	+ € 200
	Loira tonda	+ € 150	+ € 250	+ € 250
	Loira quadrata	+ € 150	+ € 250	+ € 250
Altri pannelli Other panels	Piave	+ € 100	+ € 200	+ € 200

Per porta doppia ordinare due elementi / For double door order two elements

### 8 ACCESSORI STIPITE / JAMBS ACCESSORIES

Stipite Jamb	Accessorio stipite Accessorio stipite	Pagina listino Page price book
Stipite Morbida Morbida jamb	Aggiustaggi Adjustments	P. 231

Aggiustaggi sono necessari quando i muri hanno un range di spessore diverso da 95mm-130mm  
Adjustments are necessary when the walls have a thickness range different from 95mm-130mm

### 9 CONTROTELAI PER PORTE A SCOMPARSA / COUNTERFRAMES FOR POCKET DOOR

Tipo controtelaio Counterframe type	Pagina listino Page price book
per muratura for wall	P. 227
per cartongesso for plasterboard	P. 228

### 9 BOISERIE / BOISERIE

Tipologia Topology	Sistema System	Pagina listino Page price book
Boiserie Boiserie	Pannelli incollaggio Gluing panels	P. 284

Boiserie sistema Albed disponibile su progetto. Per dettagli e prezzi contattare l'ufficio commerciale.  
Boiserie Albed system available on a project. For details and prices contact the sales office.

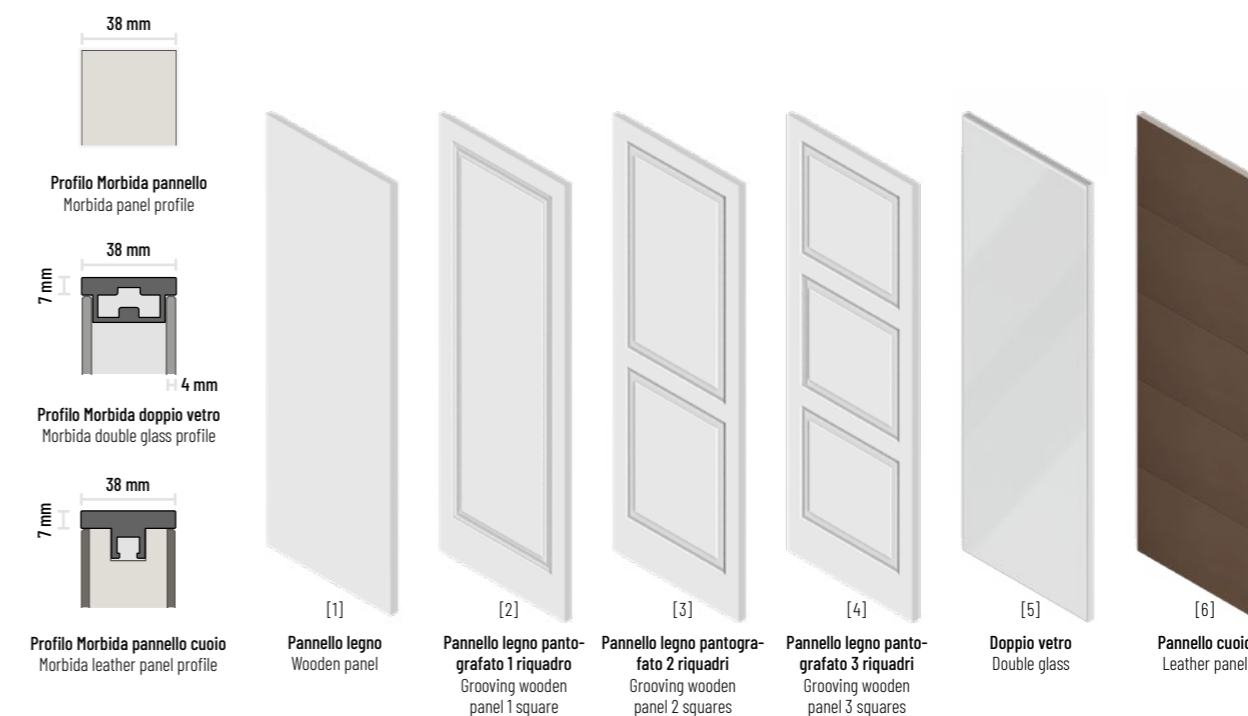

### CODICI PORTE / DOORS CODES

Tipo pannello Panel type	Stipite Morbida / Morbida jamb	
	Porta singola Single door	Porta doppia Double door
[1]	MBSM001	MBSM006
[2]	MBSM002	MBSM007
[3]	MBSM003	MBSM008
[4]	MBSM004	MBSM009
[5]	MBSM005	MBSM008
[6]	MBSM010	MBSM011

### Maniglie per porte a scomparsa Pocket door handles

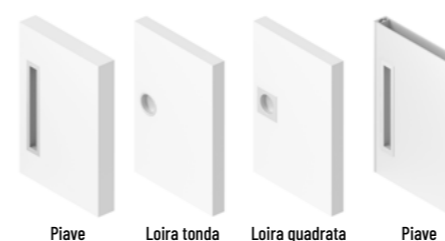

### CODICI MANIGLIE / HANDLES CODES

Maniglia Handle	Solo maniglia Only handle	Chiave Patent Patent key	Nottolino Latch free/busy
Piave	Q	Q1	Q2
Loira tonda*	V1	V2	V3
Loira quadrata*	V4	V5	V6

\* disponibile in finitura cromo satinato o lucido  
\* available in satin or polished chrome finishing

# Stipite 45° per porte a scomparsa

## Jamb 45° for pocket door

Lo stipite in alluminio tagliato a 45° è una soluzione minimale che interpreta con precisione tecnica e attenzione al dettaglio la classica cornice del vano porta.

The aluminium jamb cut at 45° is the minimal solution that involves technical precision and attention to detail, when it comes to classical framing of door openings.

### Porta singola / Single door



Porta singola  
Single door

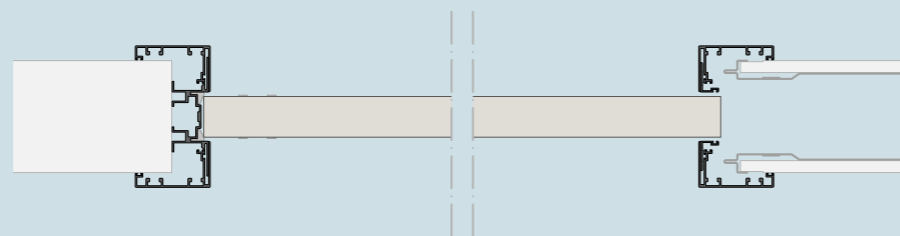

### Porta doppia / Double door



Porta doppia  
Double door

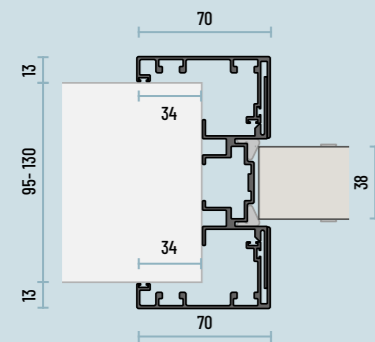
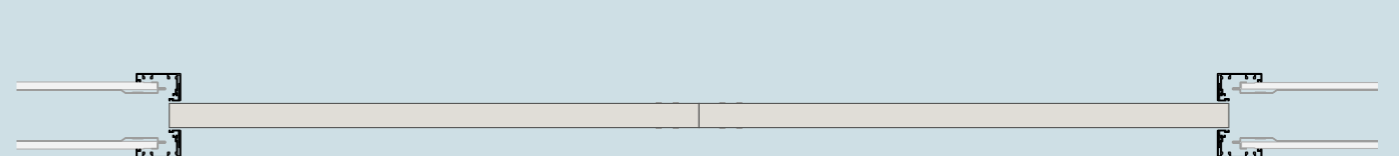

Dimensioni (mm) stipite legno per porte a scomparsa, lato di battuta  
Dimensions (mm) wooden jamb for pocket door, stop side

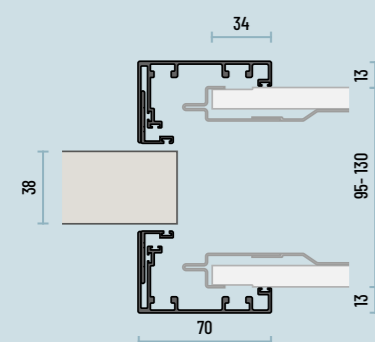

Dimensioni (mm) stipite legno per porte a scomparsa, lato di scorrimento  
Dimensions (mm) wooden jamb for pocket door, sliding side

# Stipite 45° per porte a scomparsa

## Jamb 45° for pocket door

### Compatibilità / Compatibilities

#### Quadra

P. 214

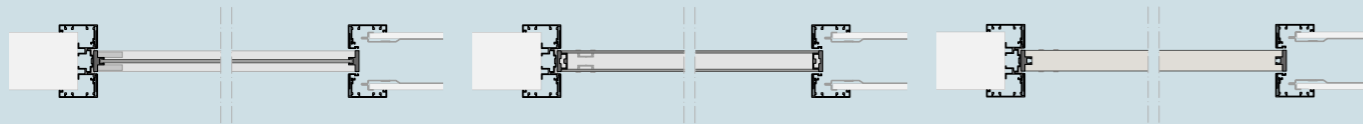

Quadra vetro singolo a scomparsa  
Quadra single glass pocket door

Quadra doppio vetro a scomparsa  
Quadra double glass pocket door

Quadra pannello legno a scomparsa  
Quadra wooden panel pocket door

#### Prima

P. 216

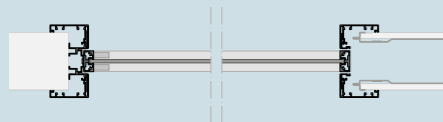

Prima a scomparsa  
Prima pocket door

#### Celine

P. 218

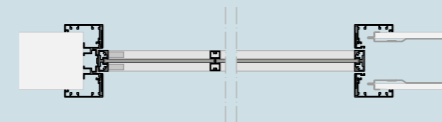

Celine a scomparsa  
Celine pocket door

#### Ri-trait

P. 220

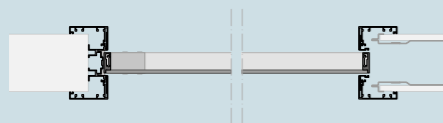

Ri-trait vetro a scomparsa  
Ri-trait glass pocket door

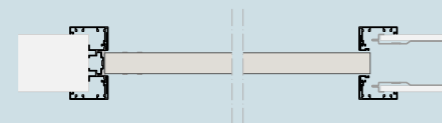

Ri-trait pannello legno a scomparsa  
Ri-trait wooden panel pocket door

#### Ri-trait 8b

P. 222

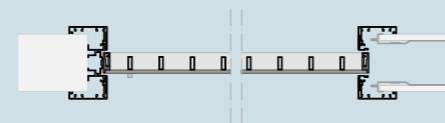

Ri-trait 8b a scomparsa  
Ri-trait 8b pocket door

#### Dot

P. 224

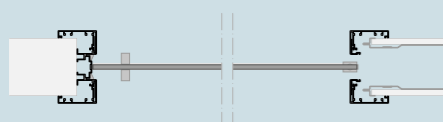

Dot a scomparsa  
Dot pocket door

### Dettagli / Details



1

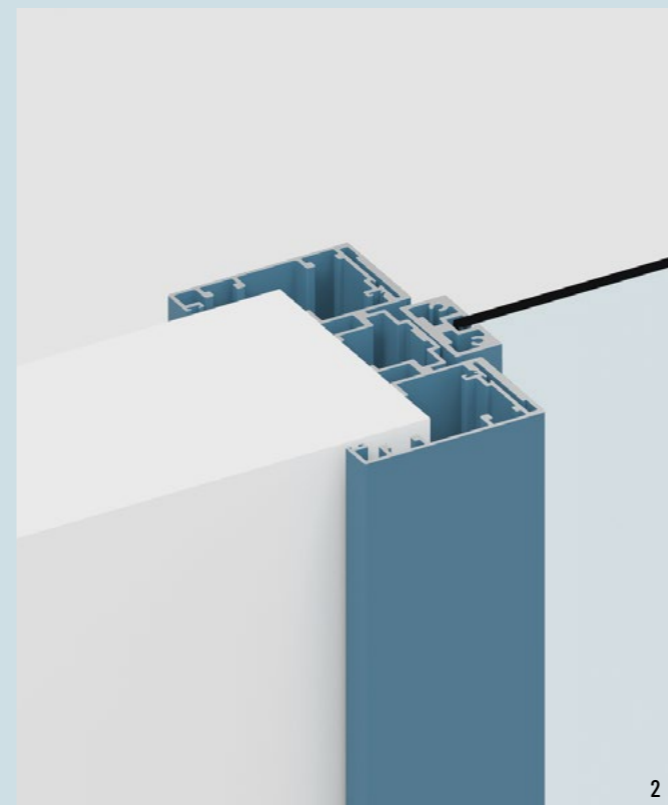

2

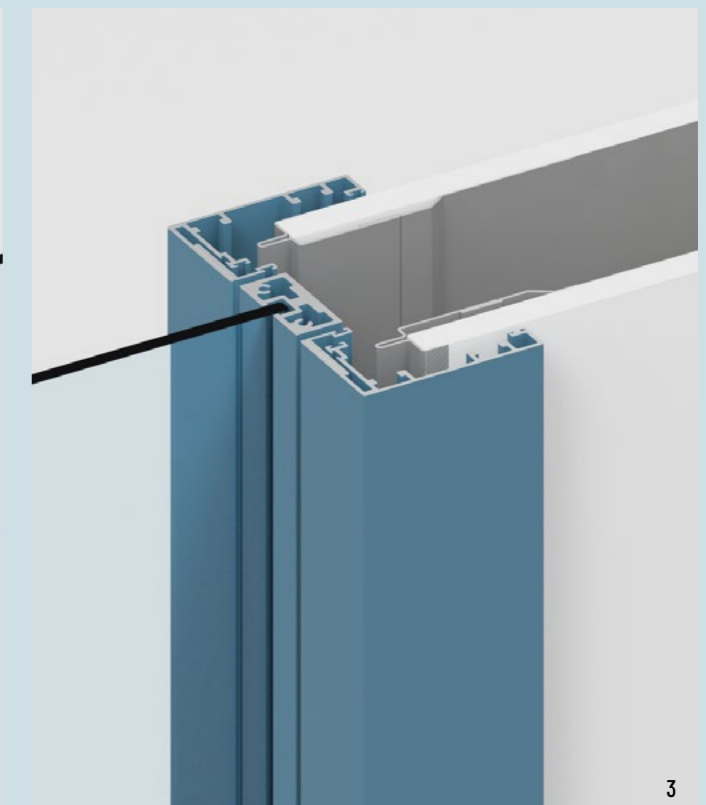

3

1. Sezione verticale Stipite 45° con Prima a scomparsa  
1. Vertical section 45° jamb with Prima pocket door

2. Sezione orizzontale Stipite 45° con Prima a scomparsa, lato battuta  
2. Horizontal section 45° jamb with Prima pocket door, stop side

3. Sezione orizzontale Stipite 45° con Prima a scomparsa, lato scorrimento  
3. Horizontal section 45° jamb with Prima pocket door, sliding side

# Stipite personalizzabile per porte a scomparsa

## Customizable jamb for pocket door

Lo stipite in alluminio personalizzabile di Albed integra un coprifilo in finitura, complanare alla cornice, che permette di personalizzare la finitura dello stipite. Il risultato è la possibilità di giocare con materiali e finiture tra legno, vetro e metalli rispondendo alle più esigenti richieste estetiche.

Albed's customizable aluminium jamb includes a finishing list, flush with the frame, which makes it possible to customize the finish on the jamb. As a result, materials and finishes can be used creatively. Wood, glass, and metal combine to meet the most demanding aesthetic requirements.

### Porta singola / Single door



Porta singola  
Single door

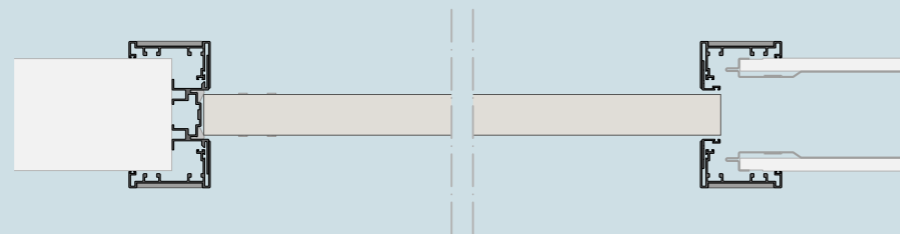

### Porta doppia / Double door



Porta doppia  
Double door

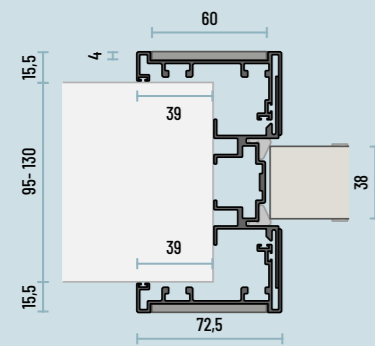
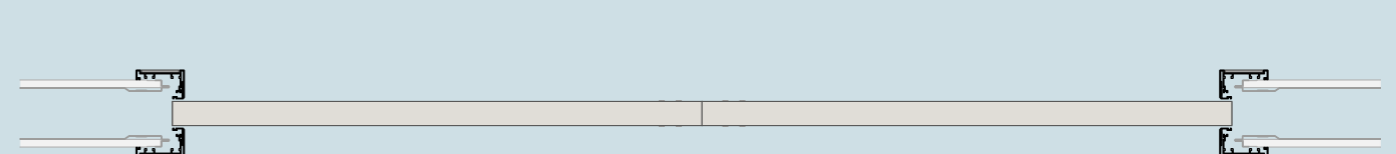

Dimensioni (mm) stipite legno per porte a scomparsa, lato di battuta  
Dimensions (mm) wooden jamb for pocket door, stop side

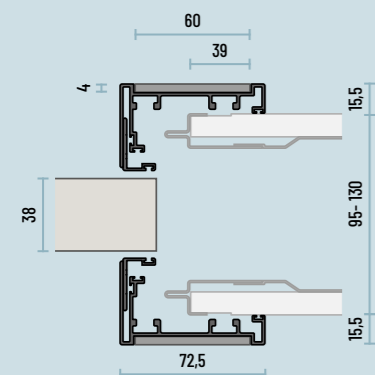

Dimensioni (mm) stipite legno per porte a scomparsa, lato di scorrimento  
Dimensions (mm) wooden jamb for pocket door, sliding side

# Stipite personalizzabile per porte a scomparsa

## Customizable jamb for pocket door

### Compatibilità / Compatibilities

#### Quadra

P. 214

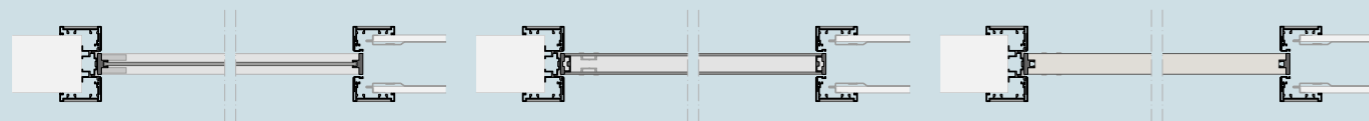

Quadra vetro singolo a scomparsa  
Quadra single glass pocket door

Quadra doppio vetro a scomparsa  
Quadra double glass pocket door

Quadra pannello legno a scomparsa  
Quadra wooden panel pocket door

#### Prima

P. 216

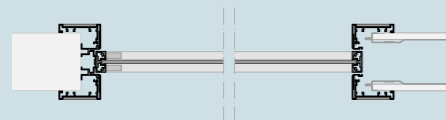

Prima a scomparsa  
Prima pocket door

#### Celine

P. 218

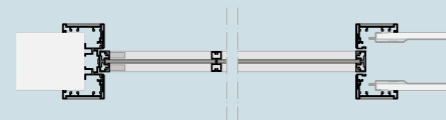

Celine a scomparsa  
Celine pocket door

#### Ri-trait

P. 220

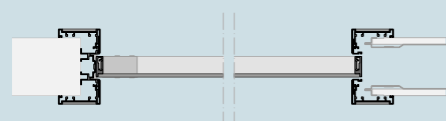

Ri-trait vetro a scomparsa  
Ri-trait glass pocket door

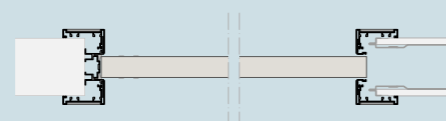

Ri-trait pannello legno a scomparsa  
Ri-trait wooden panel pocket door

#### Ri-trait 8b

P. 222

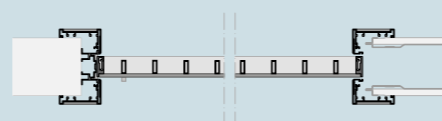

Ri-trait 8b a scomparsa  
Ri-trait 8b pocket door

#### Dot

P. 224

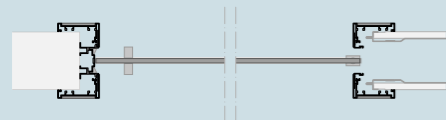

Dot a scomparsa  
Dot pocket door

### Dettagli / Details



1

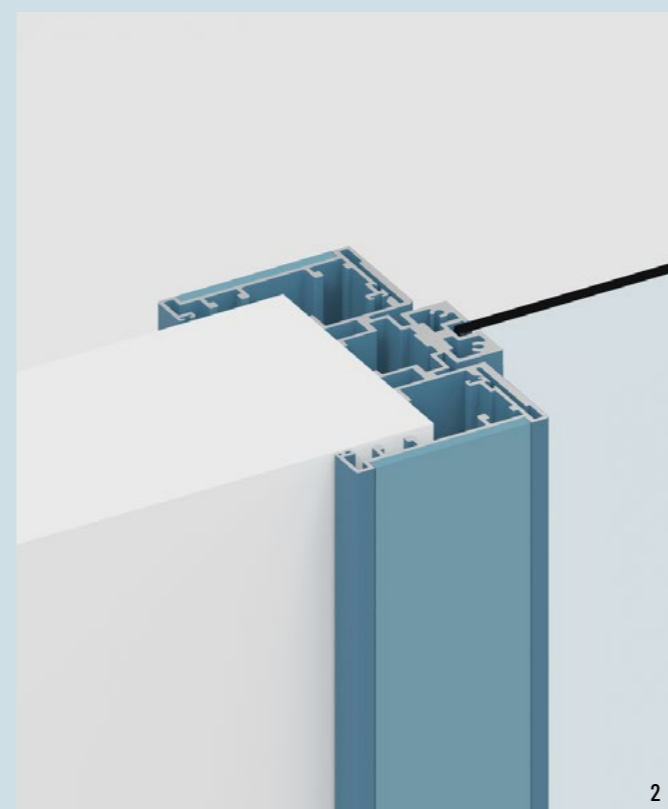

2

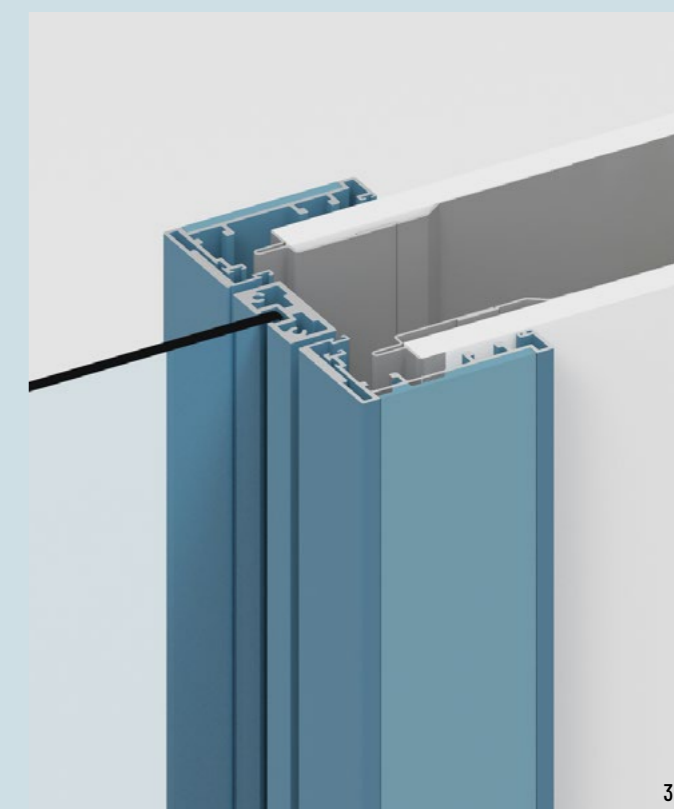

3

1. Sezione verticale Stipite personalizzabile con Prima a scomparsa  
1. Vertical section Customizable jamb with Prima pocket door

2. Sezione orizzontale Stipite personalizzabile con Prima a scomparsa, lato battuta  
2. Horizontal section Customizable jamb with Prima pocket door, stop side

3. Sezione orizzontale Stipite personalizzabile con Prima a scomparsa, lato scorrimento  
3. Horizontal section Customizable jamb with Prima pocket door, sliding side

# Stipite slim per porte a scomparsa

## Slim jamb for pocket door

Lo stipite Slim è un profilo minimale nel quale gli spessori e i dettagli tecnici del sistema porta sono stati ridotti al minimo per ottenere un raffinato inserimento tecnico del pannello porta nella parete. Le sue linee essenziali definiscono una cornice sottilissima attorno al vano porta, che disegna il passaggio.

The Slim Jamb is an minimal profile in which the door system's thicknesses and technical details are reduced to a minimum to achieve refined technical insertion of the door panel into the wall. Its clean lines define a very slim frame around the door opening, outlining the way through.

### Porta singola / Single door



Porta singola  
Single door

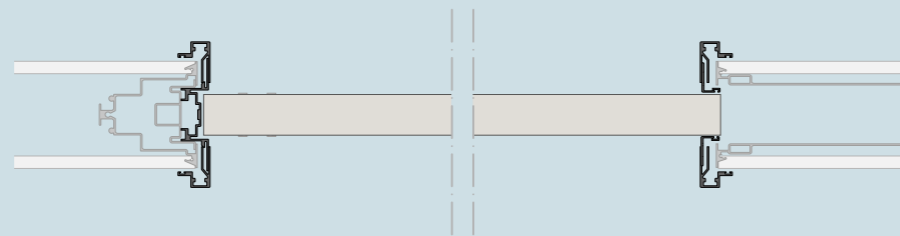

### Porta doppia / Double door



Porta doppia  
Double door

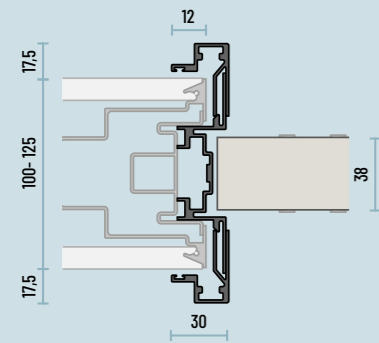
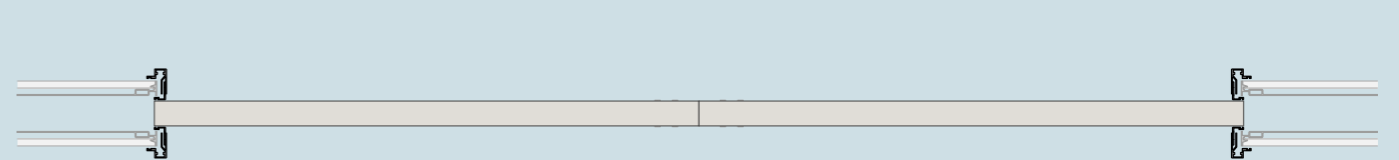

Dimensioni (mm) stipite legno per porte a scomparsa, lato di battuta  
Dimensions (mm) wooden jamb for pocket door, stop side

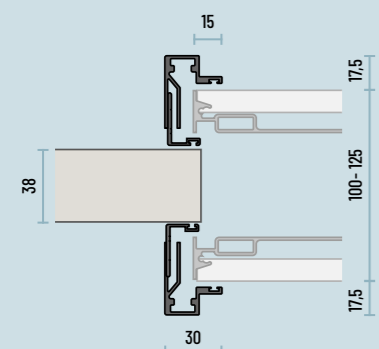

Dimensioni (mm) stipite legno per porte a scomparsa, lato di scorrimento  
Dimensions (mm) wooden jamb for pocket door, sliding side



# Stipite slim per porte a scomparsa

## Slim jamb for pocket door

### Compatibilità / Compatibilities

#### Quadra

P. 214

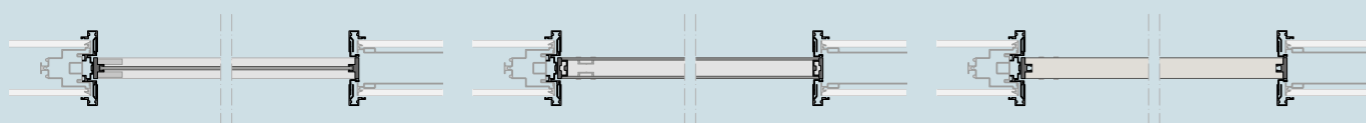

Quadra vetro singolo a scomparsa  
Quadra single glass pocket door

Quadra doppio vetro a scomparsa  
Quadra double glass pocket door

Quadra pannello legno a scomparsa  
Quadra wooden panel pocket door

#### Prima

P. 216

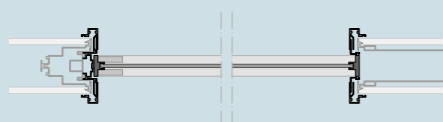

Prima a scomparsa  
Prima pocket door

#### Celine

P. 218

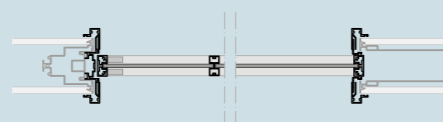

Celine a scomparsa  
Celine pocket door

#### Ri-trait

P. 230

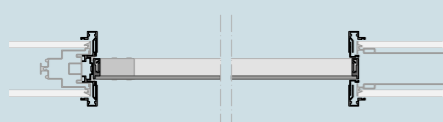

Ri-trait vetro a scomparsa  
Ri-trait glass pocket door

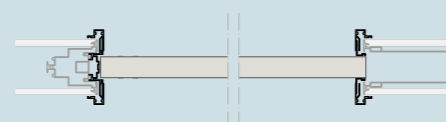

Ri-trait pannello legno a scomparsa  
Ri-trait wooden panel pocket door

#### Ri-trait 8b

P. 222

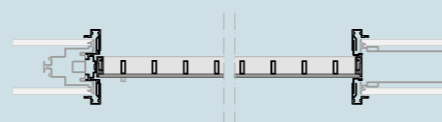

Ri-trait 8b a scomparsa  
Ri-trait 8b pocket door

#### Dot

P. 224

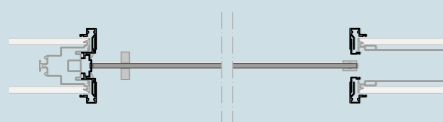

Dot a scomparsa  
Dot pocket door

### Dettagli / Details

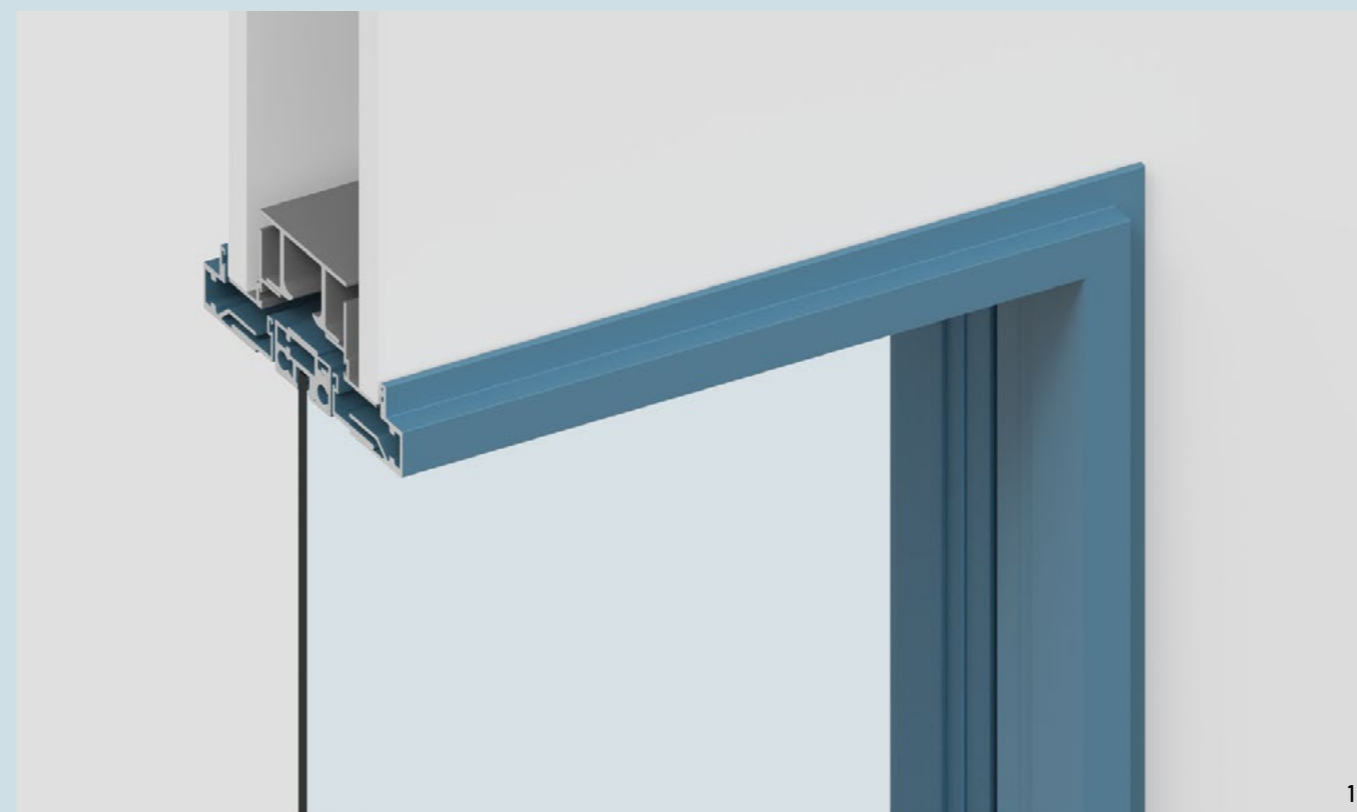

1

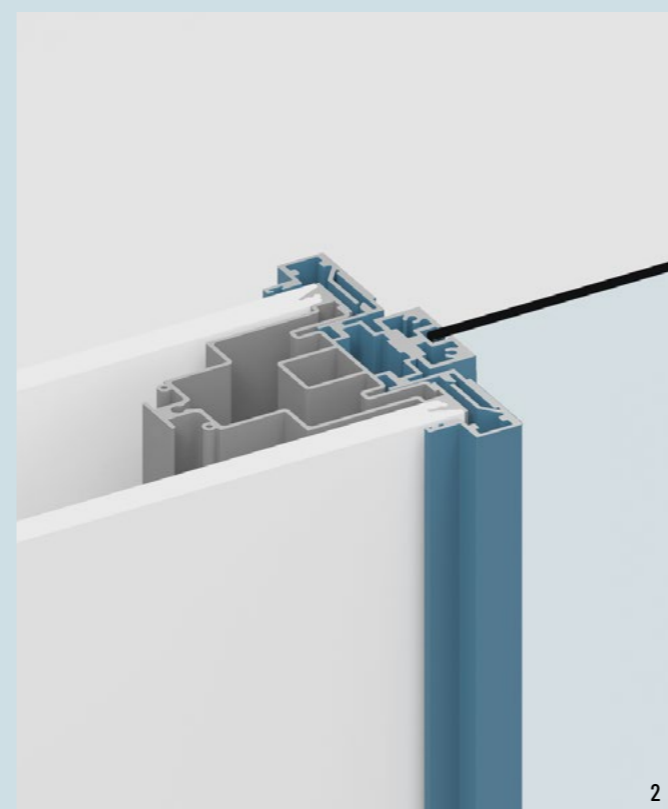

2

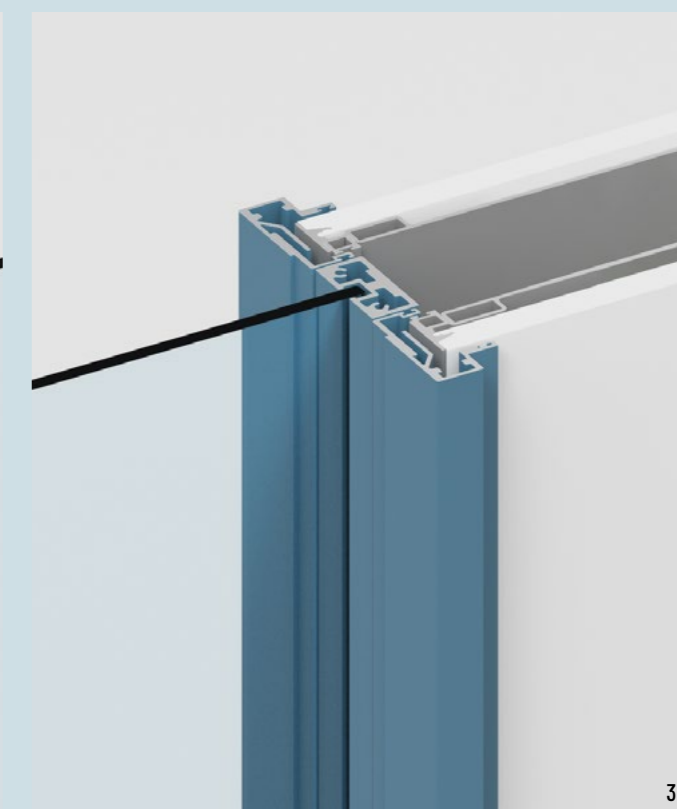

3

1. Sezione verticale Stipite slim con Prima a scomparsa  
1. Vertical section Slim jamb with Prima pocket door

2. Sezione orizzontale Stipite slim con Prima a scomparsa, lato battuta  
2. Horizontal section Slim jamb with Prima pocket door, stop side

3. Sezione orizzontale Stipite slim con Prima a scomparsa, lato scorrimento  
3. Horizontal section Slim jamb with Prima pocket door, sliding side

# Porte a scomparsa senza stipite

## Pocket door without jamb

La soluzione "senza stipiti" è la declinazione più radicalmente minimale della porta che scompare, che evidenzia il foro architettonico del vano porta, con una gestione perfetta degli spigoli e della finitura dell'imbotte.

The "without jamb" solution is the most radically minimal version of the pocket door, which highlights the architectural door opening, with edges and intradoses managed perfectly.

### Porta singola / Single door



**Porta singola**  
Single door

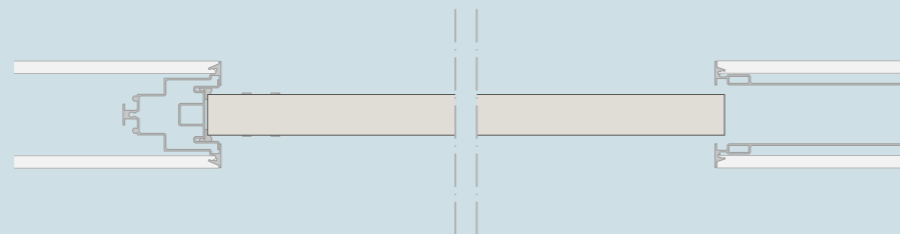

### Porta doppia / Double door



**Porta doppia**  
Double door

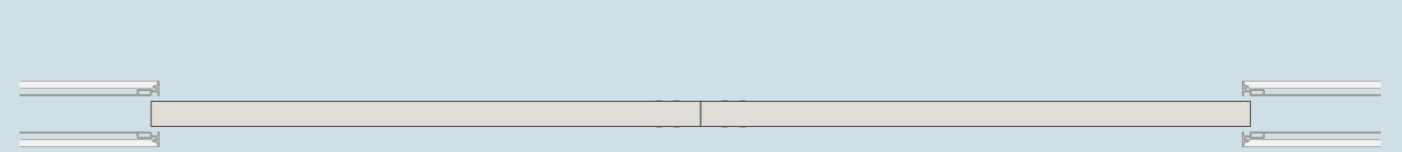

# Porte a scomparsa senza stipite

## Pocket door without jamb

### Compatibilità / Compatibilities

#### Quadra

P. 214

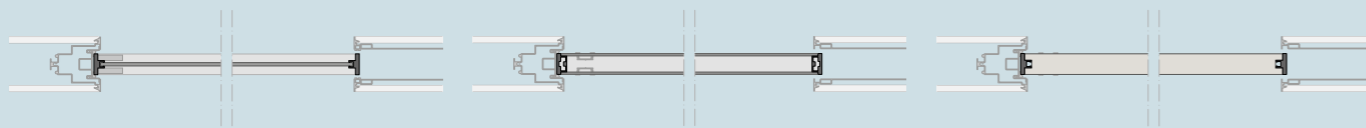

Quadra vetro singolo a scomparsa  
Quadra single glass pocket door

Quadra doppio vetro a scomparsa  
Quadra double glass pocket door

Quadra pannello legno a scomparsa  
Quadra wooden panel pocket door

#### Prima

P. 216

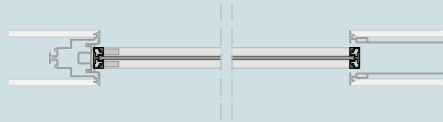

Prima a scomparsa  
Prima pocket door

#### Celine

P. 218

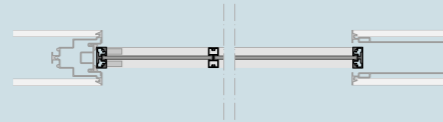

Celine a scomparsa  
Celine pocket door

#### Ri-trait

P. 230

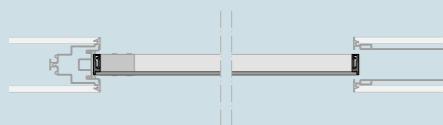

Ri-trait vetro a scomparsa  
Ri-trait glass pocket door

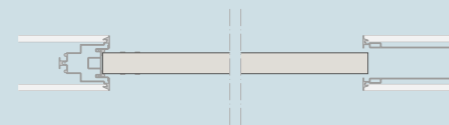

Ri-trait pannello legno a scomparsa  
Ri-trait wooden panel pocket door

#### Ri-trait 8b

P. 222

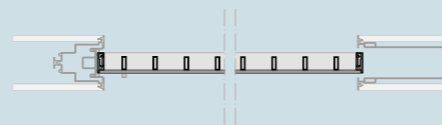

Ri-trait 8b a scomparsa  
Ri-trait 8b pocket door

#### Dot

P. 224

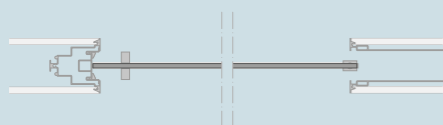

Dot a scomparsa  
Dot pocket door

### Dettagli / Details

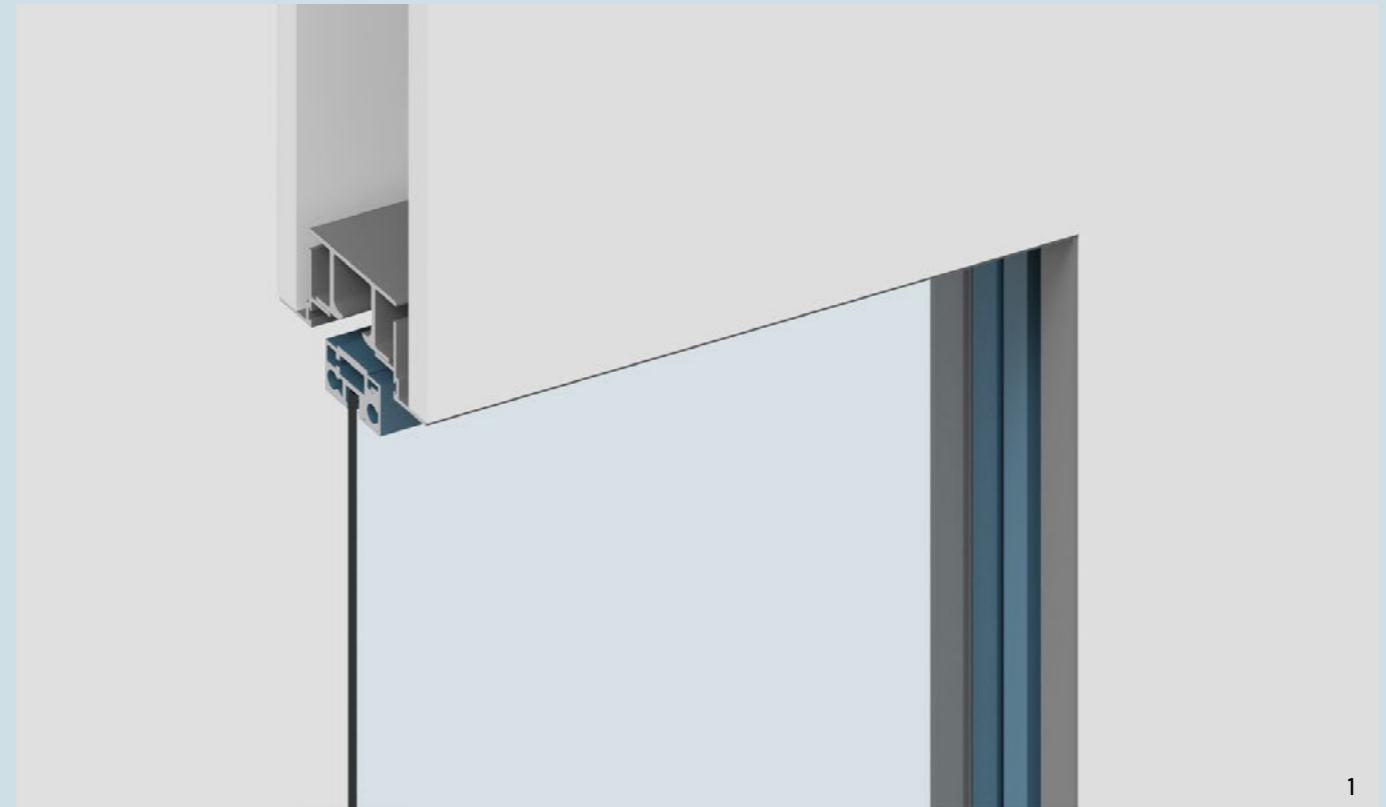

1

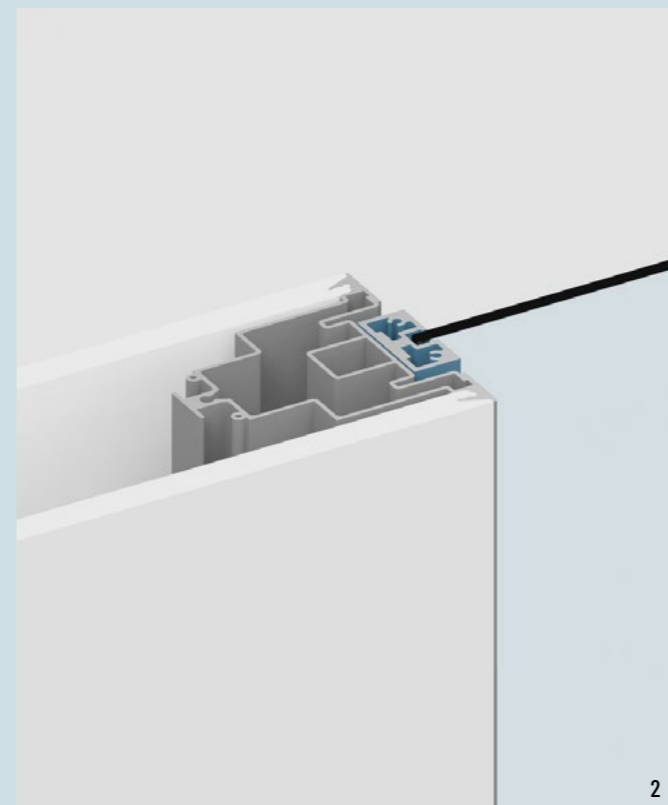

2

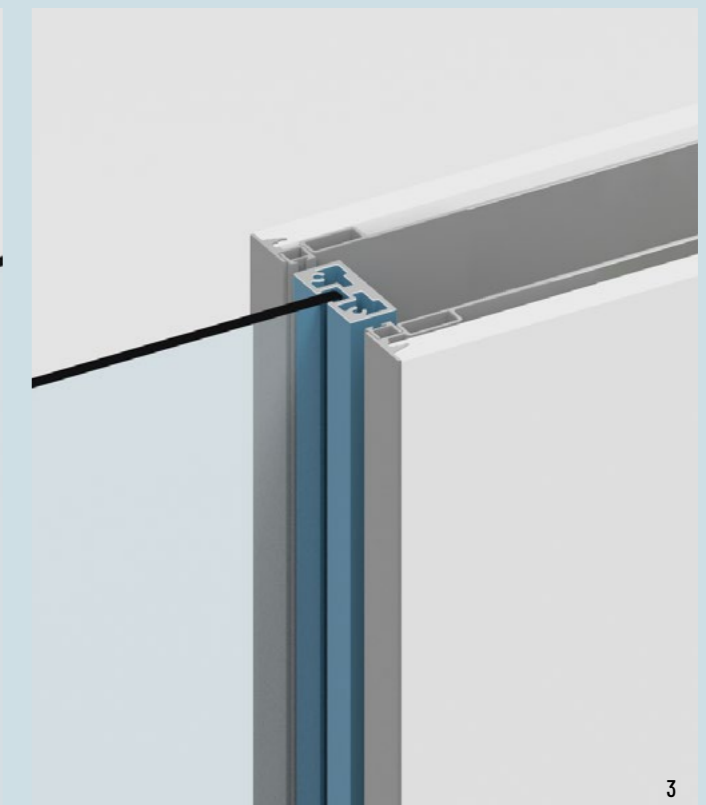

3

1. Sezione verticale Prima a scomparsa senza stipite  
1. Vertical section Prima pocket door without jamb

2. Sezione orizzontale Prima a scomparsa senza stipite, lato battuta  
2. Horizontal section Prima pocket door without jamb, stop side

3. Sezione orizzontale Prima a scomparsa senza stipite, lato scorrimento  
3. Horizontal section Prima pocket door without jamb, sliding side

# Quadra a scomparsa

## Quadra pocket door

### 1 PORTE SINGOLE STANDARD / STANDARD SINGLE DOORS

Tipo pannello	Finitura base	Finitura stipite e telaio	Stipite 45°	Stipite pers.*	Stipite Slim**	Senza stipite
Panel type	Base finishing	Jamb and frame finishing	Jamb 45°	Cust. jamb*	Slim jamb**	Without jamb
Vetro singolo	Vetro Cat. A	[1]	€ 1.445	€ 1.445	€ 1.445	€ 1.145
Doppio vetro	Vetro opaco Cat. C	Finitura alluminio anodizzato	€ 1.995	€ 1.995	€ 1.995	€ 1.695
Pannello legno	Laccato standard	Anodized aluminium finishing	€ 1.430	€ 1.430	€ 1.430	€ 1.130
Pannello cuoio	Cuoio	[7]	€ 2.200	€ 2.200	€ 2.200	€ 1.900

\* il prezzo non comprende coprifili, ordinare separatamente P. 219 / price does not include finishing lists, order separately P. 219

\*\* porte a scomparsa con Stipite Slim richiedono "controtelaio per porte a scomparsa senza stipiti"

\*\* pocket doors with Slim Jamb require "counterframe for pocket doors without jambs"

### DIMENSIONI STANDARD / STANDARD SIZES

Porta singola	Pannelli standard	Luce controtelaio
Single door	Standard panels	Counterframe clearance
Stipite 45°	L 604/704/804/904/1004 x H 2126	L 650/750/850/950/1050 ±10 x H 2150 ±10
Stipite pers.	L 604/704/804/904/1004 x H 2126	L 650/750/850/950/1050 ±10 x H 2150 ±10
Stipite Slim	L 601/701/801/901/1001 x H 2101	L 600/700/800/900/1000 +5-10 x H 2100 ±3
Senza stipite	L 623/723/823/923/1023 x H 2092	L 600/700/800/900/1000 +5-10 x H 2100 ±3

Al momento dell'ordine specificare il senso di apertura: sinistra o destra.

When ordering, specify the opening side of the door: left or right.

### 2 DIMENSIONI CUSTOM / CUSTOM SIZES

Tipo pannello	H luce controtelaio:	
Panel type	H counterframe clearance:	
Vetro singolo	H < 2700	+ € 200
Doppio vetro	H < 2700	+ € 500
Pannello legno	H < 2700	+ € 350
Pannello cuoio	H < 2700	+ € 500

Per qualsiasi larghezza luce controtelaio custom:  
 • fino a L 1050 ±10 porta singola Stipite 45° o Stipite pers.  
 • fino a L 1000 +5-10 porta singola Stipite Slim o Senza stipite  
 • fino a L 2050 ±10 porta doppia Stipite 45° o Stipite pers.  
 • fino a L 2000 +5-10 porta singola Stipite Slim o Senza stipite

For any custom counterframe clearance width:

- up to L 1050 ±10 single door Jamb 45° or Customizable jamb
- up to L 1000 +5-10 single door Slim jamb and Without jamb
- up to L 1050 ±10 double door Jamb 45° or Customizable jamb
- up to L 1000 +5-10 double door Slim jamb and Without jamb

### 3 FINITURE / FINISHINGS

Tipo pannello	Finitura	P. 30
Panel type	Finishing	
Vetro singolo	Vetro Cat. B / Glass Cat. B	+ 10%
Vetro singolo	Vetro Cat. C / Glass Cat. C	+ 15%
Vetro singolo	Vetro Cat. D / Glass Cat. D	+ 45%
Vetro singolo	Vetro Cat. E / Glass Cat. E	+ 75%
Doppio vetro	Vetro opaco Cat. D / Opaque glass Cat. D	+ 10%
Doppio vetro	Vetro traslucido / Translucent glass	+ € 150
Pannello	Essenza legno / Wood essence	+ € 270
Pannello	Laccato custom RAL / Custom RAL lacquered	+ € 200

### 4 PERSONALIZZAZIONI PERSONALIZATIONS

Tipo pannello	Divisioni vetro	
Panel type	Glass divisions	
Vetro singolo	2 divisioni / 2 divisions	[2] + € 60
Vetro singolo	3 divisioni / 3 divisions	[3] + € 120
Vetro singolo	8 divisioni / 8 divisions	[4] + € 185

### 5 PORTA DOPPIA / PORTA DOPPIA

Tipo pannello	Porta doppia	
Panel type	Double door	
Tutti i pannelli	Porta doppia	+ 90%

### DIMENSIONI STANDARD / STANDARD SIZES

Porta doppia	Pannelli standard	Luce controtelaio
double door	Standard panels	Counterframe clearance
Stipite 45°	L 608/708/808/908/1008 x H 2126	L 1250/1450/1650/1850/2050 ±10 x H 2150 ±10
Stipite pers.	L 608/708/808/908/1008 x H 2126	L 1250/1450/1650/1850/2050 ±10 x H 2150 ±10
Stipite Slim	L 605/705/805/905/1005 x H 2001/2101	L 1200/1400/1600/1800/2000 +5-10 x H 2100 ±3
Senza stipite	L 612/712/812/912/1012 x H 2092	L 1200/1400/1600/1800/2000 +5-10 x H 2100 ±3

### 6 MANIGLIA E SERRATURA / HANDLES AND LOCK

Tipo pannello	Maniglia	Solo maniglia	Chiave Patent	Nottolino
Panel type	Handle	Only handle	Patent key	Latch free/busy
Vetro singolo	Loira	+ € 150	+ € 250	+ € 250
Vetro singolo	Adige 100mm	+ € 100	-	-
Vetro singolo	Adige 300mm	+ € 200	-	-
Altri pannelli	Piave	+ € 100	+ € 200	+ € 200

Per porta doppia ordinare due elementi / For double door order two elements

### 7 ACCESSORI STIPITE / JAMBS ACCESSORIES

Stipite	Accessorio stipite	Pagina listino
Jamb	Accessorio stipite	Page price book
Stipite 45° / Jamb 45°	Aggiustaggi / Adjustments	P. 231
Stipite pers. / Cust. jamb	Aggiustaggi / Adjustments	P. 231
Stipite pers. / Cust. jamb	Coprifili / Finishing lists	
Stipite slim / Slim jamb	Aggiustaggi / Adjustments	P. 231

Aggiustaggi sono necessari quando i muri hanno un range di spessore diverso da 95mm-130mm (per Stipite 45° e Stipite Personalizzabile) o diverso da 100mm-125mm (per Stipite Slim)  
 Adjustments are necessary when the walls have a thickness range different from 95mm-130mm (for Jamb 45° and Customizable Jamb) or different from 100mm-125mm (for Slim Jamb)

### 8 CONTROTELAI PER PORTE A SCOMPARSA / COUNTERFRAMES FOR POCKET DOOR

Tipo controtelaio	Pagina listino
Counterframe type	Page price book
per muratura	P. 227
per cartongesso	P. 228

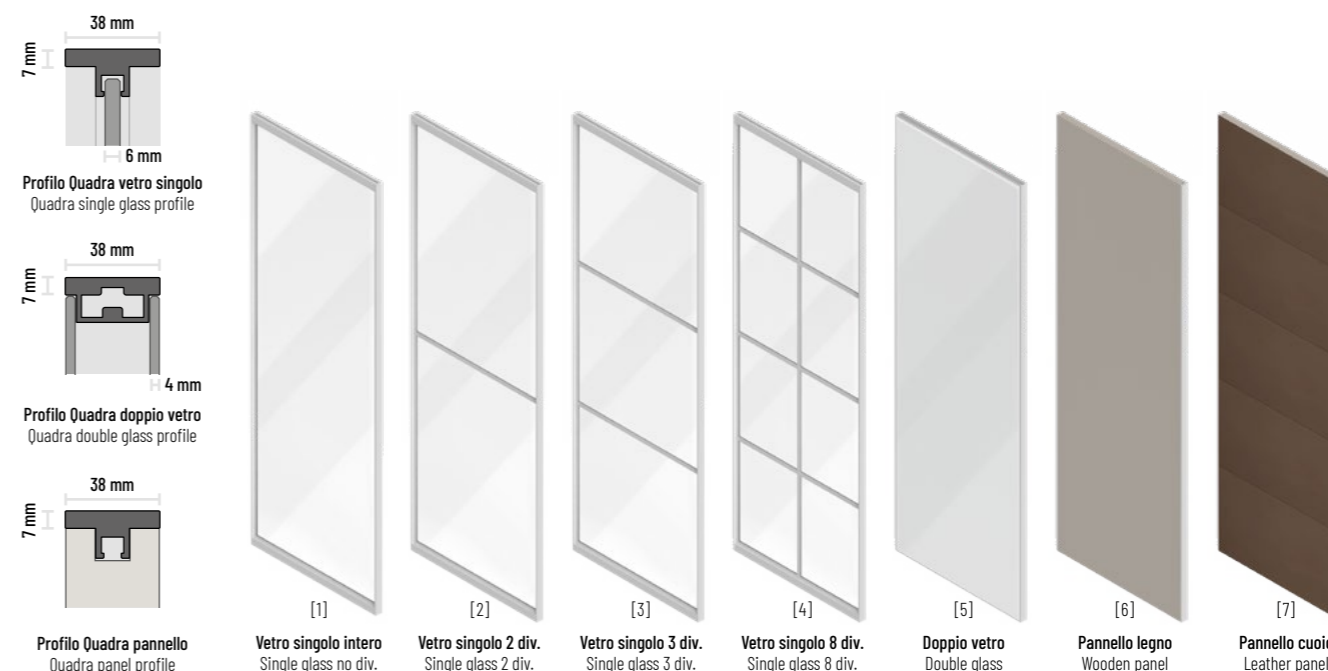

### CODICI PORTE / DOORS CODES

Tipo pannello	Stipite 45° / Jamb 45°		Stipite pers. / Cust. jamb		Stipite slim / Slim jamb		Senza stipite / Without jamb	
	Porta singola	Porta doppia	Porta singola	Porta doppia	Porta singola	Porta doppia	Porta singola	Porta doppia
Panel type	Single door	Double door	Single door	Double door	Single door	Double door	Single door	Double door
[1]	QD-SC50	QD-SC60	QD-SC10	QD-SC20	QD-SC100	QD-SC120	QD-SC30	QD-SC40
[2]	QD-SC52	QD-SC62	QD-SC12	QD-SC22	QD-SC102	QD-SC122	QD-SC32	QD-SC42
[3]	QD-SC54	QD-SC64	QD-SC14	QD-SC24	QD-SC104	QD-SC124	QD-SC34	QD-SC44
[4]	QD-SC55	QD-SC65	QD-SC15	QD-SC25	QD-SC106	QD-SC126	QD-SC35	QD-SC45
[5]	QD-SC58	QD-SC68	QD-SC18	QD-SC28	QD-SC114	QD-SC134	QD-SC38	QD-SC48
[6]	QD-SC56	QD-SC66	QD-SC16	QD-SC26	QD-SC110	QD-SC130	QD-SC36	QD-SC46
[7]	QD-SC57	QD-SC67	QD-SC17	QD-SC27	QD-SC112	QD-SC132	QD-SC37	QD-SC47

### Maniglie per porte a scomparsa

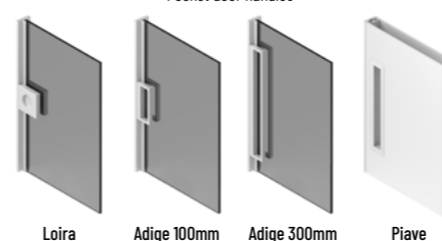

### CODICI MANIGLIE / HANDLES CODES

Maniglia	Solo maniglia	Chiave Patent	Nottolino
Handle	Only handle	Patent key	Latch free/busy
Loira	A1	A3	A2
Adige 100mm	R	-	-
Adige 300mm	R2	-	-
Piave	Q	Q1	Q2

# Prima a scomparsa

## Prima pocket door

### 1 PORTE SINGOLE STANDARD / STANDARD SINGLE DOORS

Tipo pannello	Finitura base	Finitura stipite e telaio	Stipite 45°	Stipite pers.*	Stipite Slim**	Senza stipite
Panel type	Base finishing	Jamb and frame finishing	Jamb 45°	Cust. jamb*	Slim jamb**	Without jamb
Vetro	Vetro Cat. A	Finitura alluminio anodizzato o RAL 9003 / Anodized alumi- num finishing or RAL 9003	€ 1.290	€ 1.290	€ 1.290	€ 990
Glass	Glass Cat. A					

\* il prezzo non comprende coprifili, ordinare separatamente P. 219 / price does not include finishing lists, order separately P. 219

\*\* porte a scomparsa con Stipite Slim richiedono "controtelaio per porte a scomparsa senza stipiti"

\*\* pocket doors with Slim Jamb require "counterframe for pocket doors without jambs"

### DIMENSIONI STANDARD / STANDARD SIZES

Porta singola	Pannelli standard	Luce controtelaio
Single door	Standard panels	Counterframe clearance
Stipite 45°	L 604/704/804/904/1004 x H 2126	L 650/750/850/950/1050 ±10 x H 2150 ±10
Jamb 45°		
Stipite pers.	L 604/704/804/904/1004 x H 2126	L 650/750/850/950/1050 ±10 x H 2150 ±10
Cust. jamb		
Stipite Slim	L 601/701/801/901/1001 x H 2101	L 600/700/800/900/1000 +5-10 x H 2100 ±3
Slim jamb		
Senza stipite	L 624/724/824/924/1024 x H 2092	L 600/700/800/900/1000 +5-10 x H 2100 ±3
Without jamb		

Al momento dell'ordine specificare il senso di apertura:

sinistra o destra.

When ordering, specify the opening side of the door: left or right.

### 2 DIMENSIONI CUSTOM / CUSTOM SIZES

Tipo pannello	H luce controtelaio:	
Panel type	H counterframe clearance:	
Vetro	H < 2700	+ € 200
Glass		

Per qualsiasi larghezza luce controtelaio custom:

\* fino a L 1050 ±10 porta singola Stipite 45° o Stipite pers.

\* fino a L 1000 +5-10 porta singola Stipite Slim o Senza stipite

\* fino a L 2050 ±10 porta doppia Stipite 45° o Stipite pers.

\* fino a L 2000 +5-10 porta singola Stipite Slim o Senza stipite

For any custom counterframe clearance width:

\* up to L 1050 ±10 single door Jamb 45° or Customizable jamb

\* up to L 1000 +5-10 single door Slim jamb and Without jamb

\* up to L 1050 ±10 double door Jamb 45° or Customizable jamb

\* up to L 1000 +5-10 double door Slim jamb and Without jamb

### 3 FINITURE / FINISHINGS

Tipo pannello	Finitura	P. 30
Panel type	Finishing	
Vetro	Vetro Cat. B / Glass Cat. B	+ 10%
Glass		
Vetro	Vetro Cat. C / Glass Cat. C	+ 15%
Glass		
Vetro	Vetro Cat. D / Glass Cat. D	+ 45%
Glass		
Vetro	Vetro Cat. E / Glass Cat. E	+ 75%
Glass		

### 4 PERSONALIZZAZIONI / PERSONALIZATION

Tipo pannello	Divisioni vetro	
Panel type	Glass divisions	
Vetro	2 divisioni / 2 divisions	[2] + € 60
Glass		
Vetro	3 divisioni / 3 divisions	[3] + € 120
Glass		

### 5 PORTA DOPPIA / PORTA DOPPIA

Tipo pannello	Porta doppia	
Panel type	Double door	
Tutti i pannelli	Porta doppia	+ 90%
All panels	Double door	

### DIMENSIONI STANDARD / STANDARD SIZES

Porta doppia	Pannelli standard	Luce controtelaio
double door	Standard panels	Counterframe clearance
Stipite 45°	L 606/706/806/906/1006 x H 2126	L 1250/1450/1650/1850/2050 ±10 x H 2150 ±10
Jamb 45°		
Stipite pers.	L 606/706/806/906/1006 x H 2126	L 1250/1450/1650/1850/2050 ±10 x H 2150 ±10
Cust. jamb		
Stipite Slim	L 605/705/805/905/1005 x H 2101	L 1200/1400/1600/1800/2000 +5-10 x H 2100 ±3
Slim jamb		
Senza stipite	L 612/712/812/912/1012 x H 2092	L 1200/1400/1600/1800/2000 +5-10 x H 2100 ±3
Without jamb		

### 6 MANIGLIA E SERRATURA / HANDLES AND LOCK

Tipo pannello	Maniglia	Solo maniglia	Chiave Patent	Nottolino
Panel type	Handle	Only handle	Patent key	Latch free/busy
Vetro	Loira	+ € 150	+ € 250	+ € 250
Glass				
Vetro	Adige 200mm	+ € 100	-	-
Glass				

Per porta doppia ordinare due elementi / For double door order two elements

### 7 ACCESSORI STIPITE / JAMBS ACCESSORIES

Stipite	Accessorio stipite	Pagina listino
Jamb	Accessorio stipite	Page price book
Stipite 45° / Jamb 45°	Aggiustaggi / Adjustments	P. 231
	Aggiustaggi / Adjustments	
Stipite pers. / Cust. jamb	Coprifili / Finishing lists	P. 231
Stipite slim / Slim jamb	Aggiustaggi / Adjustments	P. 231

Aggiustaggi sono necessari quando i muri hanno un range di spessore diverso da 95mm-130mm

(per Stipite 45° e Stipite Personalizzabile) o diverso da 100mm-125mm (per Stipite Slim)

Adjustments are necessary when the walls have a thickness range different from 95mm-130mm

(for Jamb 45° and Customizable Jamb) or different from 100mm-125mm (for Slim Jamb)

### 8 CONTROTELAI PER PORTE A SCOMPARSA / COUNTERFRAMES FOR POCKET DOOR

Tipo controtelaio	Pagina listino
Counterframe type	Page price book
per muratura	P. 227
for wall	
per cartongesso	P. 228
for plasterboard	

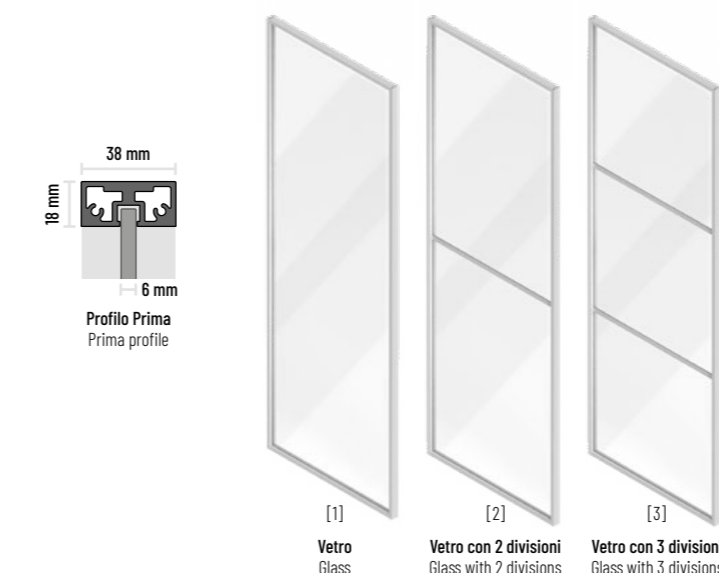

### CODICI PORTE / DOORS CODES

Tipo pannello	Stipite 45° / Jamb 45°		Stipite pers. / Cust. jamb		Stipite slim / Slim jamb		Senza stipite / Without jamb	
	Porta singola	Porta doppia	Porta singola	Porta doppia	Porta singola	Porta doppia	Porta singola	Porta doppia
Panel type	Single door	Double door	Single door	Double door	Single door	Double door	Single door	Double door
[1]	PR-SC10	PR-SC20	PRSX001	PRSX002	PR-SC50	PR-SC60	PR-SC30	PR-SC40
[2]	PR-SC12	PR-SC22	PRSX003	PRSX004	PRSZ001	PRSZ002	PR-SC32	PR-SC42
[3]	PR-SC14	PR-SC24	PRSX005	PRSX005	PRSZ003	PRSZ004	PR-SC34	PR-SC44

### Maniglie per porte a scomparsa

Pocket door handles

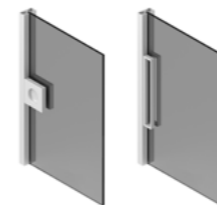

Loira

Adige 200mm

### CODICI MANIGLIE / HANDLES CODES

Maniglia	Solo maniglia	Chiave Patent	Nottolino
Handle	Only handle	Patent key	Latch free/busy
Loira	C1	C2	C3
Adige 200mm	M	-	-

# Celine a scomparsa

## Celine pocket door

### 1 PORTE SINGOLE STANDARD / STANDARD SINGLE DOORS

Tipo pannello Panel type	Finitura base Base finishing	Finitura stipite e telaio Jamb and frame finishing	Stipite 45° Jamb 45°	Stipite pers.* Cust. jamb*	Stipite Slim** Slim jamb**	Senza stipite Without jamb	
Vetro Glass	Vetro Cat. A Glass Cat. A	Finitura alluminio anodizzato o RAL 9003 Anodized aluminum finishing or RAL 9003	[1] [2]	€ 1.420	€ 1.420	€ 1.340	€ 1.120
			[3] [4] [5] [6]	€ 1.520	€ 1.520	€ 1.440	€ 1.220

\* il prezzo non comprende coprifili, ordinare separatamente P. 219 / price does not include finishing lists, order separately P. 219

\*\* porte a scomparsa con Stipite Slim richiedono "contro telaio per porte a scomparsa senza stipite"

\*\* pocket doors with Slim Jamb require "counterframe for pocket doors without jambs"

### DIMENSIONI STANDARD / STANDARD SIZES

Porta singola Single door	Pannelli standard Standard panels	Luce contro telaio Counterframe clearance
Stipite 45° Jamb 45°	L 604/704/804/904/ 1004 x H 2126	L 650/750/850/950/ 1050 ±10 x H 2150 ±10
Stipite pers. Cust. jamb	L 604/704/804/904/ 1004 x H 2126	L 650/750/850/950/ 1050 ±10 x H 2150 ±10
Stipite Slim Slim jamb	L 601/701/801/901/ 1001 x H 2101	L 600/700/800/900/ 1000 +5-10 x H 2100 ±3
Senza stipite Without jamb	L 624/724/824/924/ 1024 x H 2092	L 600/700/800/900/ 1000 +5-10 x H 2100 ±3

Al momento dell'ordine specificare il senso di apertura:

sinistra o destra.

When ordering, specify the opening side of the door: left or right.

### 2 DIMENSIONI CUSTOM / CUSTOM SIZES

Tipo pannello Panel type	H luce contro telaio: H counterframe clearance:	
Vetro Glass	H < 2700	+ € 200

Per qualsiasi larghezza luce contro telaio custom:

- fino a L 1050 ±10 porta singola Stipite 45° o Stipite pers.
- fino a L 1000 +5-10 porta singola Stipite Slim o Senza stipite
- fino a L 2050 ±10 porta doppia Stipite 45° o Stipite pers.
- fino a L 2000 +5-10 porta singola Stipite Slim o Senza stipite

For any custom counterframe clearance width:

- up to L 1050 ±10 single door Jamb 45° or Customizable jamb
- up to L 1000 +5-10 single door Slim jamb and Without jamb
- up to L 1050 ±10 double door Jamb 45° or Customizable jamb
- up to L 1000 +5-10 double door Slim jamb and Without jamb

### 3 FINITURE / FINISHINGS

Tipo pannello Panel type	Finitura Finishing	P. 30
Vetro Glass	Vetro Cat. B / Glass Cat. B	+ 10%
	Vetro Cat. C / Glass Cat. C	+ 15%
Vetro Glass	Vetro Cat. D / Glass Cat. D	+ 45%
	Vetro Cat. E / Glass Cat. E	+ 75%

Specificare 2 finiture diverse per le divisioni del vetro.

Specify 2 different finishes for the glass divisions.

In caso di 3 o più finiture diverse sovrapprezzo + 5%

In case of 3 or more different finishes, surcharge of + 5%

Per finiture di categorie diverse il prezzo viene calcolato sulla categoria più alta.

For finishes of different categories the price is calculated on the highest category.

### 4 PORTA DOPPIA / PORTA DOPPIA

Tipo pannello Panel type	Porta doppia Double door	
Tutti i pannelli All panels	Porta doppia Double door	+ 90%

### DIMENSIONI STANDARD / STANDARD SIZES

Porta doppia double door	Pannelli standard Standard panels	Luce contro telaio Counterframe clearance
Stipite 45° Jamb 45°	L 606/706/806/906/ 1006 x H 2126	L 1250/1450/1650/1850/ 2050 ±10 x H 2150 ±10
Stipite pers. Cust. jamb	L 606/706/806/906/ 1006 x H 2126	L 1250/1450/1650/1850/ 2050 ±10 x H 2150 ±10
Stipite Slim Slim jamb	L 605/705/805/905/ 1005 x H 2001/2101	L 1200/1400/1600/1800/ 2000 +5-10 x H 2100 ±3
Senza stipite Without jamb	L 612/712/812/912/ 1012 x H 2092	L 1200/1400/1600/1800/ 2000 +5-10 x H 2100 ±3

### 5 MANIGLIA E SERRATURA / HANDLES AND LOCK

Tipo pannello Panel type	Maniglia Handle	Solo maniglia Only handle	Chiave Patent Patent key	Nottolino Latch free/busy
Vetro Glass	Loira Adige 200mm	+ € 150 + € 100	+ € 250 -	+ € 250 -

Per porta doppia ordinare due elementi / For double door order two elements

### 6 ACCESSORI STIPITE / JAMBS ACCESSORIES

Stipite Jamb	Accessorio stipite Accessorio stipite	Pagina listino Page price book
Stipite 45° / Jamb 45°	Aggiustaggi / Adjustments	P. 231
Stipite pers. / Cust. jamb	Aggiustaggi / Adjustments Coprifili / Finishing lists	P. 231
Stipite slim / Slim jamb	Aggiustaggi / Adjustments	P. 231

Aggiustaggi sono necessari quando i muri hanno un range di spessore diverso da 95mm-130mm

(per Stipite 45° e Stipite Personalizzabile) o diverso da 100mm-125mm (per Stipite Slim)

Adjustments are necessary when the walls have a thickness range different from 95mm-130mm

(for Jamb 45° and Customizable Jamb) or different from 100mm-125mm (for Slim Jamb)

### 8 CONTROTELAI PER PORTE A SCOMPARSA / COUNTERFRAMES FOR POCKET DOOR

Tipo controtelaio Counterframe type	Pagina listino Page price book
per muratura for wall	P. 227
per cartongesso for plasterboard	P. 228

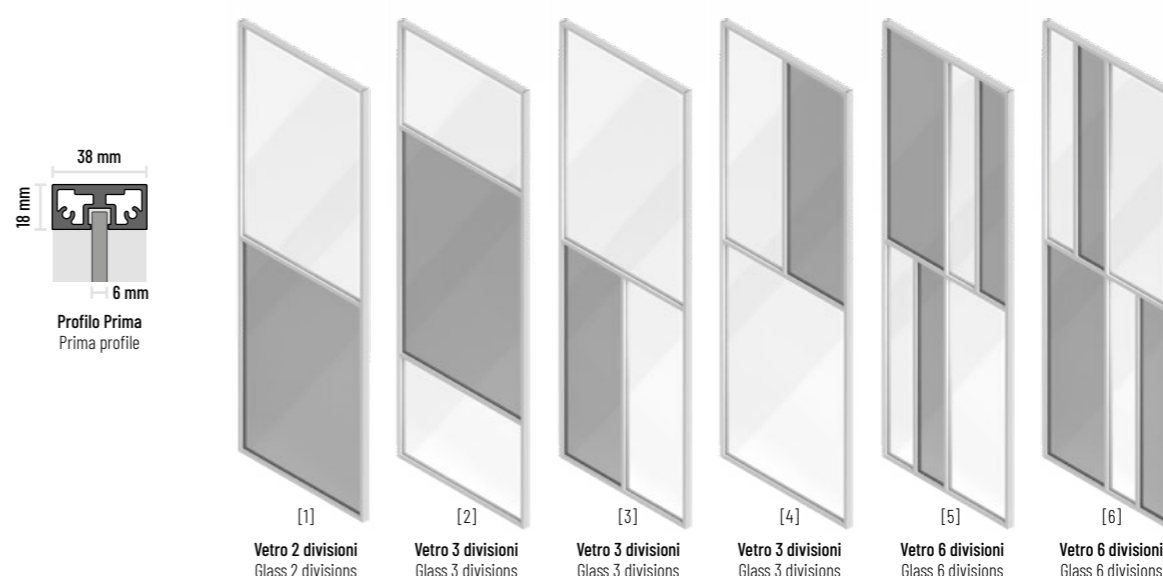

### CODICI PORTE / DOORS CODES

Tipo pannello Panel type	Stipite 45° / Jamb 45°		Stipite pers. / Cust. jamb		Stipite slim / Slim jamb		Senza stipite / Without jamb	
	Porta singola Single door	Porta doppia Double door	Porta singola Single door	Porta doppia Double door	Porta singola Single door	Porta doppia Double door	Porta singola Single door	Porta doppia Double door
[1]	CL-SC20	CL-SC50	CL-SC10	CL-SC40	CL-SC30	CL-SC60	CL-SC70	CL-SC80
[2]	CL-SC22	CL-SC52	CL-SC12	CL-SC42	CL-SC32	CL-SC62	CL-SC72	CL-SC82
[3]	CL-SC24	CL-SC54	CL-SC14	CL-SC44	CL-SC34	CL-SC64	CL-SC74	CL-SC84
[4]	CL-SC26	CL-SC56	CL-SC16	CL-SC46	CL-SC36	CL-SC66	CL-SC76	CL-SC86
[5]	CL-SC28	CL-SC58	CL-SC18	CL-SC48	CL-SC38	CL-SC68	CL-SC78	CL-SC88
[6]	CL-SC29	CL-SC59	CL-SC19	CL-SC49	CL-SC39	CL-SC69	CL-SC79	CL-SC89

### Maniglie per porte a scomparsa Pocket door handles

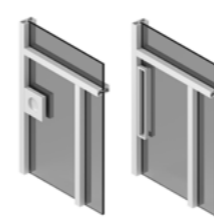

Loira

Adige 200mm

### CODICI MANIGLIE / HANDLES CODES

Maniglia Handle	Solo maniglia Only handle	Chiave Patent Patent key	Nottolino Latch free/busy
Loira	C1	C2	C3
Adige 200mm	M	-	-

# Ri-trait a scomparsa

## Ri-trait pocket door

### 1 PORTE SINGOLE STANDARD / STANDARD SINGLE DOORS

Tipo pannello Panel type	Finitura base Base finishing	Finitura stipite e telaio Jamb and frame finishing	Stipite 45° Jamb 45°	Stipite pers.* Cust. jamb*	Stipite Slim** Slim jamb**	Senza stipite Without jamb
<b>Vetro</b> Glass	<b>Vetro Cat. A</b> Glass Cat. A	<b>Finitura alluminio anodizzato / Anodized aluminum finishing</b> [1]	€ 1.445	€ 1.445	€ 1.445	€ 1.145
<b>Pannello legno</b> Wooden panel	<b>Laccato standard</b> Standard lacquered	<b>Finitura alluminio anodizzato / Anodized aluminum finishing</b> [2]	€ 1.380	€ 1.380	€ 1.380	€ 1.080

\* il prezzo non comprende coprifili, ordinare separatamente P. 219 / price does not include finishing lists, order separately P. 219

\*\* porte a scomparsa con Stipite Slim richiedono "contro telaio per porte a scomparsa senza stipiti"

\*\* pocket doors with Slim Jamb require "counterframe for pocket doors without jambs"

### DIMENSIONI STANDARD / STANDARD SIZES

Porta singola Single door	Pannelli standard Standard panels	Luce contro telaio Counterframe clearance
<b>Stipite 45°</b> Jamb 45°	L 604/704/804/904/ 1004 x H 2126	L 650/750/850/950/ 1050 ±10 x H 2150 ±10
<b>Stipite pers.</b> Cust. jamb	L 604/704/804/904/ 1004 x H 2126	L 650/750/850/950/ 1050 ±10 x H 2150 ±10
<b>Stipite Slim</b> Slim jamb	L 601/701/801/901/ 1001 x H 2101	L 600/700/800/900/ 1000 +5-10 x H 2100 ±3
<b>Senza stipite</b> Without jamb	L 623/723/823/923/ 1023 x H 2092	L 600/700/800/900/ 1000 +5-10 x H 2100 ±3

Al momento dell'ordine specificare il senso di apertura:

sinistra o destra.

When ordering, specify the opening side of the door: left or right.

### 2 DIMENSIONI CUSTOM / CUSTOM SIZES

Tipo pannello Panel type	H luce contro telaio: H counterframe clearance:	
<b>Vetro singolo</b> Single glass	H < 2700	+ € 200
<b>Pannello legno</b> Wooden panel	H < 2700	+ € 350

Per qualsiasi larghezza luce contro telaio custom:

\* fino a L 1050 ±10 porta singola Stipite 45° o Stipite pers.

\* fino a L 1000 +5-10 porta singola Stipite Slim o Senza stipite

\* fino a L 2050 ±10 porta doppia Stipite 45° o Stipite pers.

\* fino a L 2000 +5-10 porta singola Stipite Slim o Senza stipite

For any custom counterframe clearance width:

\* up to L 1050 ±10 single door Jamb 45° or Customizable jamb

\* up to L 1000 +5-10 single door Slim jamb and Without jamb

\* up to L 1050 ±10 double door Jamb 45° or Customizable jamb

\* up to L 1000 +5-10 double door Slim jamb and Without jamb

### 3 FINITURE / FINISHINGS

Tipo pannello Panel type	Finitura Finishing	P. 30
<b>Vetro singolo</b> Single glass	<b>Vetro Cat. B / Glass Cat. B</b>	+ 10%
	<b>Vetro Cat. C / Glass Cat. C</b>	+ 15%
	<b>Vetro Cat. D / Glass Cat. D</b>	+ 45%
	<b>Vetro Cat. E / Glass Cat. E</b>	+ 75%
<b>Pannello legno</b> Wooden panel	<b>Essenza legno / Wood essence</b>	+ € 270
	<b>Laccato custom RAL / Custom RAL lacquered</b>	+ € 200

### 4 PORTA DOPPIA / PORTA DOPPIA

Tipo pannello Panel type	Porta doppia Double door	
<b>Tutti i pannelli</b> All panels	<b>Porta doppia</b> Double door	+ 90%

### DIMENSIONI STANDARD / STANDARD SIZES

Porta doppia double door	Pannelli standard Standard panels	Luce contro telaio Counterframe clearance
<b>Stipite 45°</b> Jamb 45°	L 608/708/808/908/ 1008 x H 2126	L 1250/1450/1650/1850/ 2050 ±10 x H 2150 ±10
<b>Stipite pers.</b> Cust. jamb	L 608/708/808/908/ 1008 x H 2126	L 1250/1450/1650/1850/ 2050 ±10 x H 2150 ±10
<b>Stipite Slim</b> Slim jamb	L 605/705/805/905/ 1005 x H 2101	L 1200/1400/1600/1800/ 2000 +5-10 x H 2100 ±3
<b>Senza stipite</b> Without jamb	L 612/712/812/912/ 1012 x H 2092	L 1200/1400/1600/1800/ 2000 +5-10 x H 2100 ±3

### 5 MANIGLIA E SERRATURA / HANDLES AND LOCK

Tipo pannello Panel type	Maniglia Handle	Solo maniglia Only handle	Chiave Patent Patent key	Nottolino Latch free/busy
<b>Vetro singolo</b> Single glass	<b>Piave</b>	+ € 100	+ € 200	+ € 200
	<b>Piave</b>	+ € 100	+ € 200	+ € 200
<b>Pannello legno</b> Wooden panel	<b>Loira tonda</b>	+ € 150	+ € 250	+ € 250
	<b>Loira quadrata</b>	+ € 150	+ € 250	+ € 250

Per porta doppia ordinare due elementi / For double door order two elements

### 6 ACCESSORI STIPITE / JAMBS ACCESSORIES

Stipite Jamb	Accessorio stipite Accessorio stipite	Pagina listino Page price book
<b>Stipite 45° / Jamb 45°</b>	<b>Aggiustaggi / Adjustments</b>	P. 231
<b>Stipite pers. / Cust. jamb</b>	<b>Aggiustaggi / Adjustments</b> <b>Coprifili / Finishing lists</b>	P. 231
<b>Stipite slim / Slim jamb</b>	<b>Aggiustaggi / Adjustments</b>	P. 231

Aggiustaggi sono necessari quando i muri hanno un range di spessore diverso da 95mm-130mm

(per Stipite 45° e Stipite Personalizzabile) o diverso da 100mm-125mm (per Stipite Slim)

Adjustments are necessary when the walls have a thickness range different from 95mm-130mm

(for Jamb 45° and Customizable Jamb) or different from 100mm-125mm (for Slim Jamb)

### 7 CONTROTELAI PER PORTE A SCOMPARSA / COUNTERFRAMES FOR POCKET DOOR

Tipo contro telaio Counterframe type	Pagina listino Page price book
<b>per muratura</b> for wall	P. 227
<b>per cartongesso</b> for plasterboard	P. 228

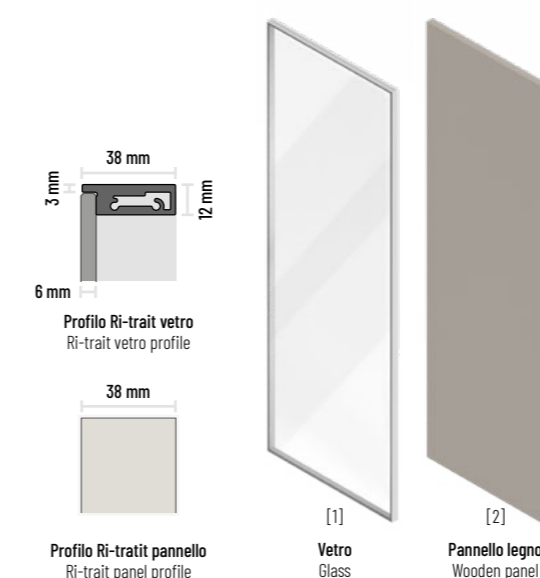

### CODICI PORTE / DOORS CODES

Tipo pannello Panel type	Stipite 45° / Jamb 45°		Stipite pers. / Cust. jamb		Stipite slim / Slim jamb		Senza stipite / Without jamb	
	Porta singola Single door	Porta doppia Double door	Porta singola Single door	Porta doppia Double door	Porta singola Single door	Porta doppia Double door	Porta singola Single door	Porta doppia Double door
[1]	TR-SC50	TR-SC60	TR-SC10	TR-SC20	TR-SC70	TR-SC72	TR-SC30	TR-SC40
[2]	TR-SC56	TR-SC66	TR-SC16	TR-SC26	TR-SC74	TR-SC76	TR-SC36	TR-SC46

### Maniglie per porte a scomparsa Pocket door handles



### CODICI MANIGLIE / HANDLES CODES

Maniglia Handle	Solo maniglia Only handle	Chiave Patent Patent key	Nottolino Latch free/busy
<b>Piave</b>	Q	Q1	Q2
<b>Loira tonda*</b>	V1	V2	V3
<b>Loira quadrata*</b>	V4	V5	V6

\*disponibile in finitura cromo satinato o lucido

\*available in satin or polished chrome finishing

# Ri-trait 8b a scomparsa

## Ri-trait 8b pocket door

### 1 PORTE SINGOLE STANDARD / STANDARD SINGLE DOORS

Tipo pannello Panel type	Finitura base Base finishing	Finitura stipite e telaio Jamb and frame finishing	Stipite 45° Jamb 45°	Stipite pers.* Cust. jamb*	Stipite Slim** Slim jamb**	Senza stipite Without jamb	
Vetro Glass	Vetro Cat. A Glass Cat. A	Finitura alluminio anodizzato / Anodized aluminum finishing	[1] [2] [3] [4]	€ 1.950	€ 1.950	€ 1.950	€ 1.650

\* il prezzo non comprende coprifili, ordinare separatamente P. 219 / price does not include finishing lists, order separately P. 219

\*\* porte a scomparsa con Stipite Slim richiedono "contro telaio per porte a scomparsa senza stipiti"

\*\* pocket doors with Slim Jamb require "counterframe for pocket doors without jambs"

### DIMENSIONI STANDARD / STANDARD SIZES

Porta singola Single door	Pannelli standard Standard panels	Luce contro telaio Counterframe clearance
Stipite 45° Jamb 45°	L 604/704/804/904/ 1004 x H 2126	L 650/750/850/950/ 1050 ±10 x H 2150 ±10
Stipite pers. Cust. jamb	L 604/704/804/904/ 1004 x H 2126	L 650/750/850/950/ 1050 ±10 x H 2150 ±10
Stipite Slim Slim jamb	L 601/701/801/901/ 1001 x H 2101	L 600/700/800/900/ 1000 +5-10 x H 2100 ±3
Senza stipite Without jamb	L 623/723/823/923/ 1023 x H 2092	L 600/700/800/900/ 1000 +5-10 x H 2100 ±3

Al momento dell'ordine specificare il senso di apertura:

sinistra o destra.

When ordering, specify the opening side of the door: left or right.

### 2 DIMENSIONI CUSTOM / CUSTOM SIZES

Tipo pannello Panel type	H luce contro telaio: H counterframe clearance:	
Vetro Glass	H < 2700	+ € 360

Per qualsiasi larghezza luce contro telaio custom:

- fino a L 1050 ±10 porta singola Stipite 45° o Stipite pers.
- fino a L 1000 +5-10 porta singola Stipite Slim o Senza stipite
- fino a L 2050 ±10 porta doppia Stipite 45° o Stipite pers.
- fino a L 2000 +5-10 porta singola Stipite Slim o Senza stipite

For any custom counterframe clearance width:

- up to L 1050 ±10 single door Jamb 45° or Customizable jamb
- up to L 1000 +5-10 single door Slim jamb and Without jamb
- up to L 1050 ±10 double door Jamb 45° or Customizable jamb
- up to L 1000 +5-10 double door Slim jamb and Without jamb

### 3 FINITURE / FINISHINGS

Tipo pannello Panel type	Finitura Finishing	P. 30
Vetro Glass	Vetro Cat. B / Glass Cat. B	+ 10%
	Vetro Cat. C / Glass Cat. C	+ 15%
	Vetro Cat. D / Glass Cat. D	+ 45%

### 4 PORTA DOPPIA / PORTA DOPPIA

Tipo pannello Panel type	Porta doppia Double door	
Tutti i pannelli All panels	Porta doppia Double door	+ 90%

### DIMENSIONI STANDARD / STANDARD SIZES

Porta doppia double door	Pannelli standard Standard panels	Luce contro telaio Counterframe clearance
Stipite 45° Jamb 45°	L 608/708/808/908/ 1008 x H 2126	L 1250/1450/1650/1850/ 2050 ±10 x H 2150 ±10
Stipite pers. Cust. jamb	L 608/708/808/908/ 1008 x H 2126	L 1250/1450/1650/1850/ 2050 ±10 x H 2150 ±10
Stipite Slim Slim jamb	L 605/705/805/905/ 1005 x H 2101	L 1200/1400/1600/1800/ 2000 +5-10 x H 2100 ±3
Senza stipite Without jamb	L 612/712/812/912/ 1012 x H 2092	L 1200/1400/1600/1800/ 2000 +5-10 x H 2100 ±3

### 5 MANIGLIA E SERRATURA / HANDLES AND LOCK

Tipo pannello Panel type	Maniglia Handle	Solo maniglia Only handle	Chiave Patent Patent key	Nottolino Latch free/busy
Vetro Glass	Reno	+ € 150	-	-
	Loira	+ € 150	+ € 250	+ € 250

Per porta doppia ordinare due elementi / For double door order two elements

### 6 ACCESSORI STIPITE / JAMBS ACCESSORIES

Stipite Jamb	Accessorio stipite Accessorio stipite	Pagina listino Page price book
Stipite 45° / Jamb 45°	Aggiustaggi / Adjustments	P. 231
Stipite pers. / Cust. jamb	Aggiustaggi / Adjustments Coprifili / Finishing lists	P. 231
Stipite slim / Slim jamb	Aggiustaggi / Adjustments	P. 231

Aggiustaggi sono necessari quando i muri hanno un range di spessore diverso da 95mm-130mm (per Stipite 45° e Stipite Personalizzabile) o diverso da 100mm-125mm (per Stipite Slim)

Adjustments are necessary when the walls have a thickness range different from 95mm-130mm (for Jamb 45° and Customizable Jamb) or different from 100mm-125mm (for Slim Jamb)

### 7 CONTROTELAI PER PORTE A SCOMPARSA / COUNTERFRAMES FOR POCKET DOOR

Tipo contro telaio Counterframe type	Pagina listino Page price book
per muratura for wall	P. 227
per cartongesso for plasterboard	P. 228

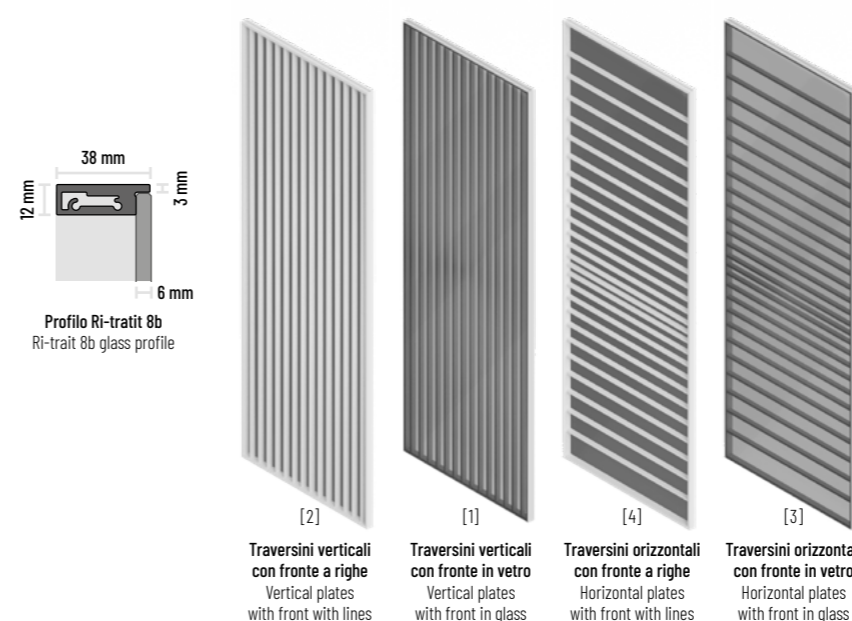

### CODICI PORTE / DOORS CODES

Tipo pannello Panel type	Stipite 45° / Jamb 45°		Stipite pers. / Cust. jamb		Stipite slim / Slim jamb		Senza stipite / Without jamb	
	Porta singola Single door	Porta doppia Double door	Porta singola Single door	Porta doppia Double door	Porta singola Single door	Porta doppia Double door	Porta singola Single door	Porta doppia Double door
[1]	TR-8BV-SC30R	TR-8BV-SC40R	TR-8BV-SC10R	TR-8BV-SC20R	TR-8BV-SC50R	TR-8BV-SC60R	TR-8BV-SC70R	TR-8BV-SC80R
[2]	TR-8BV-SC30V	TR-8BV-SC40V	TR-8BV-SC10V	TR-8BV-SC20V	TR-8BV-SC50V	TR-8BV-SC60V	TR-8BV-SC70V	TR-8BV-SC80V
[3]	TR-8BH-SC30R	TR-8BH-SC40R	TR-8BH-SC10R	TR-8BH-SC20R	TR-8BH-SC50R	TR-8BH-SC60R	TR-8BH-SC70R	TR-8BH-SC80R
[4]	TR-8BH-SC30V	TR-8BH-SC40V	TR-8BH-SC10V	TR-8BH-SC20V	TR-8BH-SC50V	TR-8BH-SC60V	TR-8BH-SC70V	TR-8BH-SC80V

### Maniglie per porte a scomparsa Pocket door handles

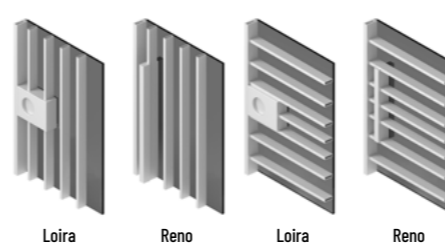

### CODICI MANIGLIE / HANDLES CODES

Maniglia Handle	Solo maniglia Only handle	Chiave Patent Patent key	Nottolino Latch free/busy
Loira	RT1	RT2	RT3
Reno verticale	K1	-	-
Reno orizzontale	K2	-	-



# Dot a scomparsa

## Dot pocket door

### 1 PORTE SINGOLE STANDARD / STANDARD SINGLE DOORS

Tipo pannello Panel type	Finitura base Base finishing	Finitura telaio Jamb finishing	Stipite 45° Jamb 45°	Stipite pers.* Cust. jamb*	Stipite Slim** Slim jamb**	Senza stipite Without jamb
Vetro Glass	Vetro traslucido cat. A / Traslucent glass cat. A	Finitura alluminio anodizzato / Anodized aluminum finishing [1]	€ 1.290	€ 1.290	€ 1.290	€ 990

\* il prezzo non comprende coprifili, ordinare separatamente P. 219 / price does not include finishing lists, order separately P. 219

\*\* porte a scomparsa con Stipite Slim richiedono "controtelaio per porte a scomparsa senza stipiti"

\*\* pocket doors with Slim Jamb require "counterframe for pocket doors without jambs"

### DIMENSIONI STANDARD / STANDARD SIZES

Porta singola Single door	Pannelli standard Standard panels	Luce controtelaio Counterframe clearance
Stipite 45° Jamb 45°	L 615/715/815/915/ 1015 x H 2120	L 650/750/850/950/ 1050 ±10 x H 2150 ±10
Stipite pers. Cust. jamb	L 615/715/815/915/ 1015 x H 2120	L 650/750/850/950/ 1050 ±10 x H 2150 ±10
Stipite Slim Slim jamb	L 606/706/806/906/ 1006 x H 2120	L 600/700/800/900/ 1000 +5-10 x H 2100 ±3
Senza stipite Without jamb	L 628/728/828/928/ 1028 x H 2092	L 600/700/800/900/ 1000 +5-10 x H 2100 ±3

Al momento dell'ordine specificare il senso di apertura:

sinistra o destra.

When ordering, specify the opening side of the door: left or right.

### 2 DIMENSIONI CUSTOM / CUSTOM SIZES

Tipo pannello Panel type	H luce controtelaio: H counterframe clearance:	
Vetro Glass	H < 2700	+ € 350

Per qualsiasi larghezza luce controtelaio custom:

• fino a L 1050 ±10 porta singola Stipite 45° o Stipite pers.

• fino a L 1000 +5-10 porta singola Stipite Slim o Senza stipite

• fino a L 2050 ±10 porta doppia Stipite 45° o Stipite pers.

• fino a L 2000 +5-10 porta singola Stipite Slim o Senza stipite

For any custom counterframe clearance width:

• up to L 1050 ±10 single door Jamb 45° or Customizable jamb

• up to L 1000 +5-10 single door Slim jamb and Without jamb

• up to L 1050 ±10 double door Jamb 45° or Customizable jamb

• up to L 1000 +5-10 double door Slim jamb and Without jamb

### 3 FINITURE / FINISHINGS

Tipo pannello Panel type	Finitura Finishing	P. 30
Vetro Glass	Vetro traslucido cat. B Traslucent glass cat. B	+ 10%
	Vetro traslucido cat. C Traslucent glass cat. C	+ 15%

### 4 PORTA DOPPIA / PORTA DOPPIA

Tipo pannello Panel type	Porta doppia Double door	
Tutti i pannelli All panels	Porta doppia Double door	+ 90%

### DIMENSIONI STANDARD / STANDARD SIZES

Porta doppia double door	Pannelli standard Standard panels	Luce controtelaio Counterframe clearance
Stipite 45° Jamb 45°	L 606/706/806/906/ 1006 x H 2126	L 1250/1450/1650/1850/ 2050 ±10 x H 2150 ±10
Stipite pers. Cust. jamb	L 606/706/806/906/ 1006 x H 2126	L 1250/1450/1650/1850/ 2050 ±10 x H 2150 ±10
Stipite Slim Slim jamb	L 605/705/805/905/ 1005 x H 2101	L 1200/1400/1600/1800/ 2000 +5-10 x H 2100 ±3
Senza stipite Without jamb	L 612/712/812/912/ 1012 x H 2092	L 1200/1400/1600/1800/ 2000 +5-10 x H 2100 ±3

### 5 MANIGLIA E SERRATURA / HANDLES AND LOCK

Tipo pannello Panel type	Maniglia Handle	Solo maniglia Only handle	Chiave Patent Patent key	Nottolino Latch free/busy
Vetro Glass	Reno 980mm	+ € 100	-	-
	Reno 1600mm	+ € 150	-	-
	Arno 600mm	+ € 100	-	-
	Arno 1600mm	+ € 150	-	-
	Ticino 400mm	+ € 150	-	-
	Ticino 1600mm	+ € 250	-	-
	Tevere	+ € 150	+ € 250	+ € 250

Per porta doppia ordinare due elementi / For double door order two elements

### 7 CONTROTELAI PER PORTE A SCOMPARSA / COUNTERFRAMES FOR POCKET DOOR

Tipo controtelaio Counterframe type	Pagina listino Page price book
per muratura for wall	P. 227
per cartongesso for plasterboard	P. 228

### 6 ACCESSORI STIPITE / JAMBS ACCESSORIES

Stipite Jamb	Accessorio stipite Accessorio stipite	Pagina listino Page price book
Stipite 45° / Jamb 45°	Aggiustaggi / Adjustments	P. 231
Stipite pers. / Cust. jamb	Aggiustaggi / Adjustments Coprifili / Finishing lists	P. 231
Stipite slim / Slim jamb	Aggiustaggi / Adjustments	P. 231

Aggiustaggi sono necessari quando i muri hanno un range di spessore diverso da 95mm-130mm

(per Stipite 45° e Stipite Personalizzabile) o diverso da 100mm-125mm (per Stipite Slim)

Adjustments are necessary when the walls have a thickness range different from 95mm-130mm

(for Jamb 45° and Customizable Jamb) or different from 100mm-125mm (for Slim Jamb)



### CODICI PORTE / DOORS CODES

Tipo pannello Panel type	Stipite 45° / Jamb 45°		Stipite pers. / Cust. jamb		Stipite slim / Slim jamb		Senza stipite / Without jamb	
	Porta singola Single door	Porta doppia Double door	Porta singola Single door	Porta doppia Double door	Porta singola Single door	Porta doppia Double door	Porta singola Single door	Porta doppia Double door
[1]	DT-SC10	DT-SC20	DTSX001	DTSX002	DTSZ001	DTSZ002	DT-SC30	DT-SC40

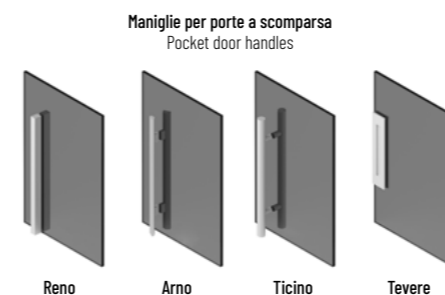

### CODICI MANIGLIE / HANDLES CODES

Maniglia Handle	Solo maniglia Only handle	Chiave Patent Patent key	Nottolino Lacth free/busy
Reno 1600mm	H	-	-
Reno 980mm	H1	-	-
Arno 1600mm	S2	-	-
Arno 600mm	S	-	-
Ticino 1600mm	T	-	-
Ticino 400mm	T1	-	-
Tevere	I	U	Z

# Un elemento fondamentale per le porte a scomparsa

## A fundamental element for pocket doors

### Cosa sono i controtelai per porte a scomparsa, come funzionano e perchè ne esistono di diverse tipologie?

What are pocket door counterframes, how do they work and why are there different types?

Le porte a scomparsa sono porte scorrevoli che, in fase di apertura, scorrono all'interno del muro, diventando invisibili. Questo tipo di soluzione ha il vantaggio di ottimizzare lo spazio, in quanto il movimento della porta avviene all'interno della muratura, ottenendo, in termini di design, ottime soluzioni estetiche.

Il sistema è dunque composto da due elementi: il pannello porta, e un secondo elemento tecnico che permette di far sparire il pannello porta al suo interno.

Il controtelaio per porte a scomparsa è un'intelaiatura composta da una cassa metallica, che consente il montaggio di un qualsiasi pannello, ed è destinato a fondersi con la parete nella fase di installazione, che solitamente coincide con la realizzazione della parete stessa. Il controtelaio è un elemento pre-assemblato che contiene già tutti gli elementi tecnici che permettono il movimento del pannello porta (binari, carrelli e fermi) ed è predisposto per ottimizzarne l'installazione.

Esistono diverse tipologie di controtelai, per pareti in muratura o cartongesso, predisposti per stipiti o soluzioni minimali senza stipiti.

Pocket doors are sliding doors that slide inside the wall, becoming invisible. This type of solution optimises the space as the door disappears into the thickness of the wall, obtaining excellent aesthetic solutions in terms of design.

The system is composed of two elements: the door panel and the counterframe for doors for cavity wall that is the second technical element that makes the door panel disappear inside it.

The counterframe for doors for cavity wall is a frame composed of a steel structure that allows the installation of any panel and it merges with the wall during the installation phase that normally correspond with the realisation of the wall itself. The counter-frame is a pre-assembled element with all the technical elements that allow the door panel to move (rails and trolleys) and optimises the installation.

There are different types of counterframes, for wall or for plasterboard, available for jambs or for minimal solutions without jambs.

# Porte a scomparsa su muratura

## Pocket door on the wall

### Controtelai per porte a scomparsa

#### Counterframe for pocket doors

Il controtelaio per pareti in muratura favorisce l'installazione in situazioni di edilizia classica con laterizi o altri materiali edili ed è predisposto per pareti realizzati con tecniche classiche.

The counterframe for masonry walls allows installation in classic building situations with bricks or other construction materials and it is suitable for walls made with classic techniques.

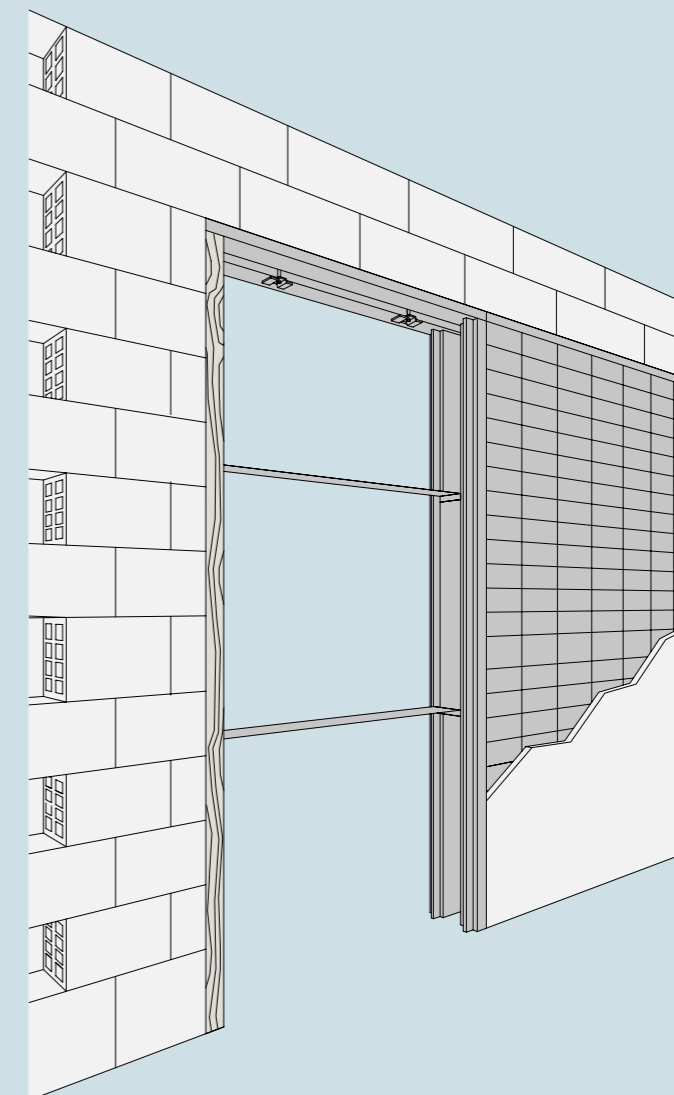

#### CONTROTELAIO PER MURATURA / COUNTERFRAME FOR WALL

Tipo controtelaio Counterframe type	Tipo porta Door type	Luce controtelaio Counterframe clearance	Porta a scomparsa / Pocket door						Codici Codes
			Stipite legno Wooden jamb	Stipite Morbida Morbida Jamb	Stipite 45° Jamb 45°	Stipite pers. Cust. jamb	Stipite slim Slim jamb	Senza cornice Without jamb	
Per porte a scomparsa con stipiti For pocket doors with jambs	porta singola single door	L 650/750/850/950/1050 ±10 x H 2150 ±10	€ 660	€ 660	€ 660	€ 660	-	-	C-SC1
	porta doppia double door	L 1250/1450/1650/1850/2050 ±10 x H 2150 ±10	€ 1.320	€ 1.320	€ 1.320	€ 1.320	-	-	C-SC10
Per porte a scomparsa senza stipiti For pocket doors without jambs	porta singola single door	L 600/700/800 +5-10 x H 2100 ±3 L 900/1000 +5-10 x H 2100 ±3	-	-	-	-	€ 1.280	€ 1.280	CS-SC2
	porta doppia double door	L 1200/1400/1600 +5-10 x H 2100 ±3 L 1800/2000 +5-10 x H 2100 ±3	-	-	-	-	€ 2.560	€ 2.560	CS-SC20
							€ 2.960	€ 2.960	SC-SC60

# Porte a scomparsa su cartongesso

## Pocket door on plasterboard

### Controtelai per porte a scomparsa

#### Counterframe for pocket doors

Il controtelaio per pareti in cartongesso favorisce il montaggio con lastre di cartongesso e l'integrazione con i montanti metallici utilizzati per la costruzione delle pareti con questo metodo.

The counter-frame for plasterboard facilitates the installation with plasterboard plates and the integration with metal profiles used for the construction of the walls with this method.

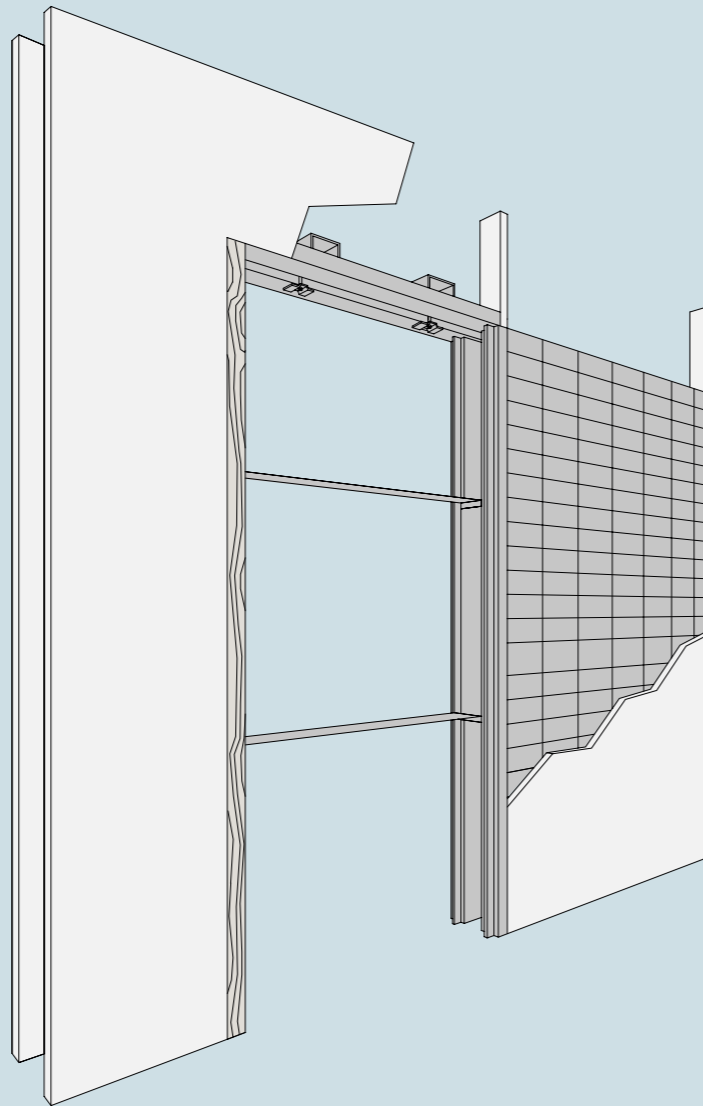

#### CONTROTELAIO PER CARTONGESSO / COUNTERFRAME FOR PLASTERBOARD

Tipo controtelaio Counterframe type	Tipo porta Door type	Luce controtelaio Counterframe clearance	Porta a scomparsa / Pocket door						Codici Codes
			Stipite legno Wooden jamb	Stipite Morbida Morbida jamb	Stipite 45° Jamb 45°	Stipite pers. Cust. jamb	Stipite slim Slim jamb	Senza cornice Without jamb	
Per porte a scomparsa con stipitii For pocket doors with jambs	porta singola single door	L 650/750/850/950/1050 ±10 x H 2150 ±10	€ 660	€ 660	€ 660	€ 660	-	-	C-SC5
	porta doppia double door	L 1250/1450/1650/1850/2050 ±10 x H 2150 ±10	€ 1.320	€ 1.320	€ 1.320	€ 1.320	-	-	C-SC50
Per porte a scomparsa senza stipitii For pocket doors without jambs	porta singola single door	L 600/700/800 +5-10 x H 2100 ±3	-	-	-	-	€ 1.120	€ 1.120	CS-SC3
	porta doppia double door	L 1200/1400/1600 +5-10 x H 2100 ±3	-	-	-	-	€ 2.240	€ 2.240	CS-SC30
		L 1800/2000 +5-10 x H 2100 ±3	-	-	-	-	€ 2.480	€ 2.480	CS-SC70

# Porte a scomparsa senza controtelaio

## Pocket door without counterframe

### Binario con Kit-pocket

#### Rail with Kit-pocket

In alcune situazioni particolari si richiede l'installazione di porte a scomparsa senza l'utilizzo del classico controtelaio. Per questo motivo, Albed propone la soluzione "Kit-Pocket". Al binario di scorrimento Evo viene effettuata una speciale lavorazione che permette l'installazione e la rimozione del binario stesso nel tempo, per poter effettuare eventuali ispezioni e/o manutenzioni senza dover nuovamente intervenire sulla muratura.

In some particular situations it is necessary to install the sliding doors for cavity wall without using the classic counter-frame. For this reason, Albed proposes the solution "Kit-Pocket". A special processing is carried out on the rail EVO that allows the installation and removal of the rail over time, in order to make any inspections or/and maintenance without having to intervene again on the masonry.

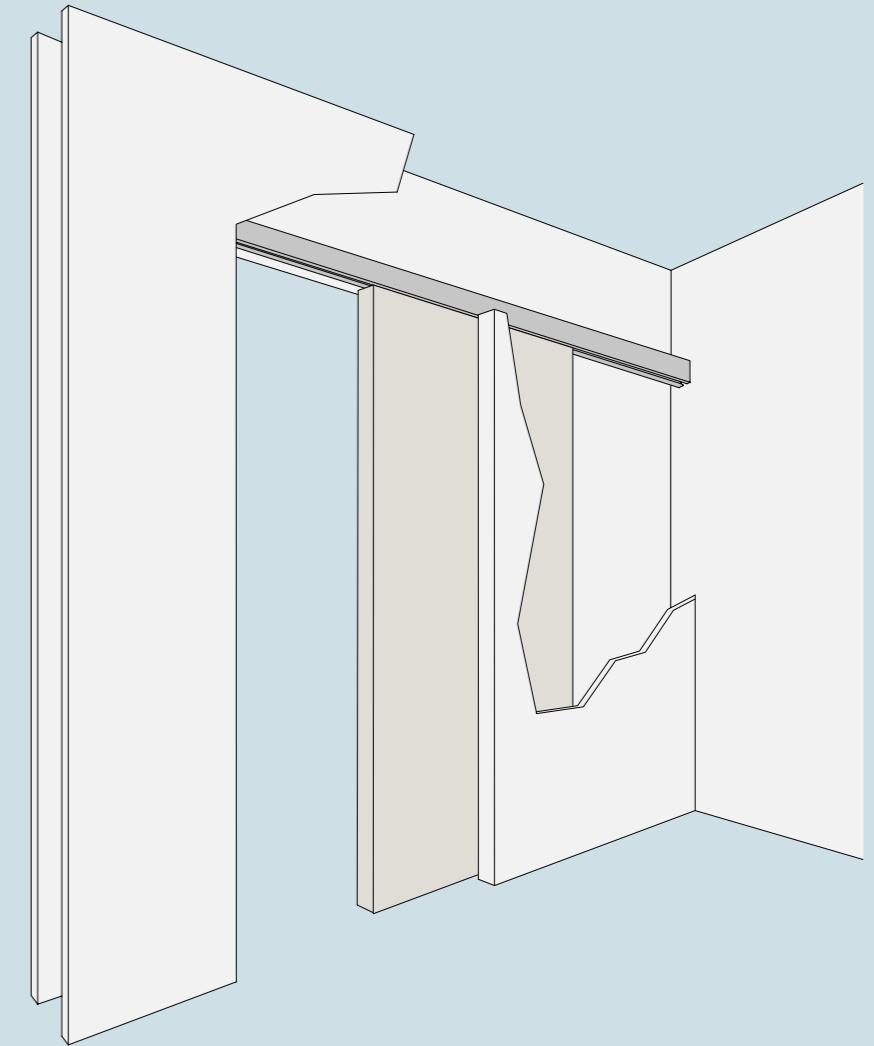

#### SISTEMA DI SCORRIMENTO\* / SLIDING SYSTEM\*

Elemento Element	1 via 1 way	2 vie 2 ways	2+1 vie 2+1 ways	1 via 1 way	2 vie 2 ways	2+1 vie 2+1 ways
Binario Evo a soffitto Ceiling Evo rail	€/ml 110	€/ml 150	€/ml 260	EQ-BS1	EQ-BS2	EQ-BS3
Kit-pocket Kit-pocket	€ 190	€ 380	€ 570	EQ-KP1	EQ-KP2	EQ-KP3

#### PANNELLI SCORREVOLI / SLIDING PANELS

Tipologia Typology	Integrazione Integration	Prodotto Product	Pagina listino Page price book
Pannello scorrevole Sliding panel	Sistema binario Evo Evo rail system	QUADRA	P. 234
		PRIMA	P. 236
		CELINE	P. 237
		RI-TRAIT	P. 238
		RI-TRAIT 8B	P. 239
		DOT	P. 240

\*Il "Kit-Pocket" è un accessorio che rende il sistema binario Evo per porte scorrevoli adattabile a soluzioni a scomparsa. Vengono riportati a lato i principali prezzi. per un'informazione completa sul sistema Evo riferirsi alla sezione dedicata a P. 235.

\*The "Kit-Pocket" is an accessory that makes the Evo rail system for sliding doors adaptable to pocket door solutions. For full information on the Evo system, please refer to the section on P. 235.

# Accessori per stipiti porte a scomparsa

## Jamb accessories for pocket doors

### Stipite legno / Wooden jamb

#### AGGIUSTAGGI / ADJUSTMENTS

Tipo aggiustaggio: Adjustment type:	Per muri di spessore: For wall thickness:	Porta singola Single door	Porta doppia Double door	Porta singola Single door	Porta doppia Double door
Singolo / Single	130mm - 200mm	€ 100	€ 120	AN-SA10	AN-SA14
Doppio / Double	155mm - 300mm	€ 200	€ 240	AN-SA12	AN-SA16

### Stipite 45° e stipite Morbida / Jamb 45° and Morbida jamb

#### AGGIUSTAGGI / ADJUSTMENTS

Tipo aggiustaggio: Adjustment type:	Per muri di spessore: For wall thickness:	Porta singola Single door	Porta doppia Double door	Porta singola Single door	Porta doppia Double door
Singolo / Single	130mm - 200mm	€ 240	€ 250	QD-SA45	QD-SA50
	155mm - 300mm	€ 325	€ 340	QD-SA46	QD-SA51
Doppio / Double	130mm - 190mm	€ 450	€ 480	QD-SA47	QD-SA52
	190mm - 250mm	€ 620	€ 650	QD-SA48	QD-SA53
	250mm - 300mm	€ 690	€ 710	QD-SA49	QD-SA54

### Stipite personalizzabile / Customizable jamb

#### AGGIUSTAGGI / ADJUSTMENTS

Tipo aggiustaggio: Adjustment type:	Per muri di spessore: For wall thickness:	Porta singola Single door	Porta doppia Double door	Porta singola Single door	Porta doppia Double door
Singolo / Single	130mm - 200mm	€ 240	€ 250	QD-SA10	QD-SA30
	155mm - 300mm	€ 325	€ 340	QD-SA12	QD-SA32
Doppio / Double	130mm - 190mm	€ 450	€ 480	QD-SA20	QD-SA40
	190mm - 250mm	€ 620	€ 650	QD-SA22	QD-SA42
	250mm - 300mm	€ 690	€ 710	QD-SA24	QD-SA44

#### COPRIFILI / FINISHING LISTS

Dimensioni: Size:	Porta singola Single door					Porta doppia Double door				
	Alluminio Aluminium	Legno/Laccato Wood/lacquered	Vetro Glass	Cuoio rigen. Regen. leather	Cuoio Leather	Alluminio Aluminium	Legno/Laccato Wood/lacquered	Vetro Glass	Cuoio rigen. Regen. leather	Cuoio Leather
Standard	€ 165	€ 200	€ 240	€ 280	€ 350	€ 165	€ 200	€ 240	€ 280	€ 350
Custom	€ 180	€ 220	€ 260	€ 340	€ 430	€ 180	€ 220	€ 260	€ 340	€ 430

#### CODICI COPRIFILI / FINISHING LISTS CODES

Coprifilo Finishing list	Porta singola Single door	Porta doppia Double door
Anteriore / Front	QD-SA60	QD-DA60
Posteriore / Back	QD-SP60	QD-DP60

### Stipite slim / Slim jamb

#### AGGIUSTAGGI / ADJUSTMENTS

Tipo aggiustaggio: Adjustment type:	Per muri di spessore: For wall thickness:	Porta singola Single door	Porta doppia Double door	Porta singola Single door	Porta doppia Double door
Singolo / Single	125mm - 170mm	€ 240	€ 250	8B-SA45	8B-SA50
	170mm - 220mm	€ 325	€ 340	8B-SA46	8B-SA51
	125mm - 200mm	€ 450	€ 480	8B-SA47	8B-SA52
Doppio / Double	200mm - 250mm	€ 620	€ 650	8B-SA48	8B-SA53
	250mm - 310mm	€ 690	€ 710	8B-SA49	8B-SA54



# PANNELLI SCORREVOLI O GIREVOLI

## SLIDING OR PIVOTING PANELS

I pannelli "scorrevoli" e i pannelli "girevoli" sono la soluzione versatile per eccellenza che, integrandosi perfettamente con l'architettura, permette la libertà progettuale di dividere e connettere gli spazi dinamicamente. Le nostre porte scorrevoli e i nostri pannelli girevoli sono disponibili con vetro singolo, doppio vetro o pannelli in legno e possono essere montati su un sistema di binari a soffitto (anche ad incasso), soffitto e pavimento, a parete. I nostri binari supportano da una a più vie, permettendo la realizzazione di sistemi divisori complessi.

The "sliding" and "pivoting" panels are the most versatile solution. It fits perfectly with the architecture and allows to divide and connect spaces dynamically. Our sliding doors and pivoting panels are available in single or double glass, or wood panels, and can be mounted on a system of ceiling rails (also built-in), ceiling and floor, wall-mounted. Our rails support from one to several ways systems to create complex dividing systems.



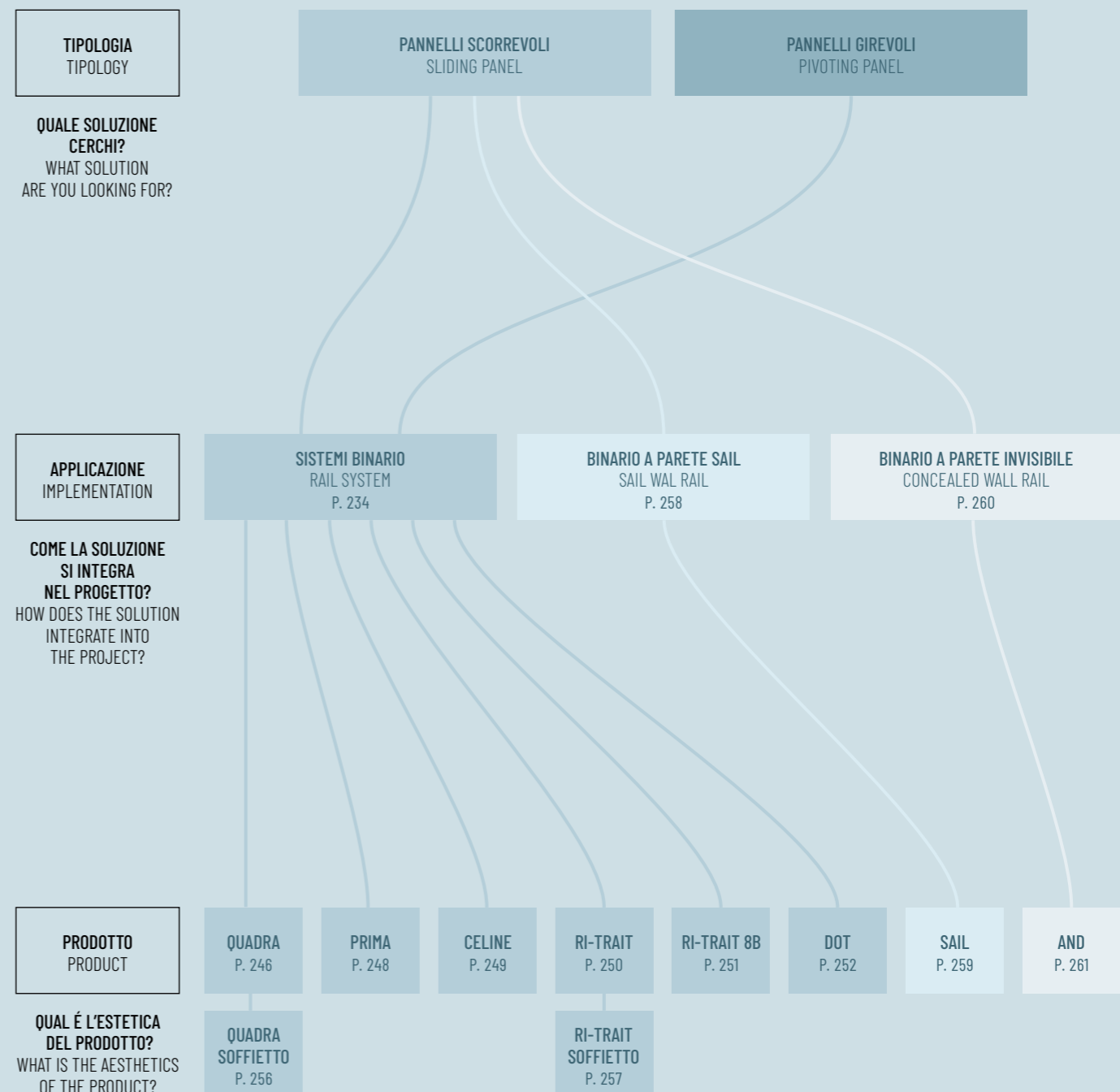



### Sistema prodotto / Product system

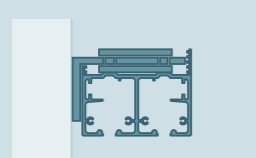
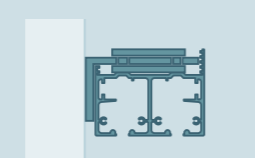
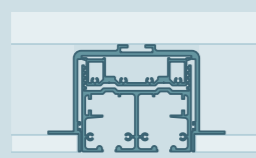
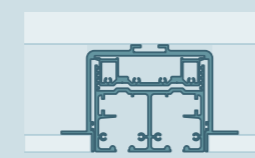

# Sistemi binario Albed

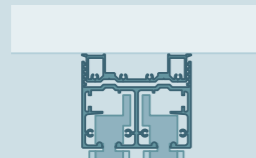
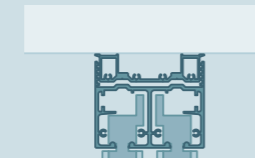
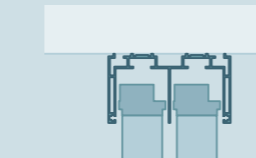
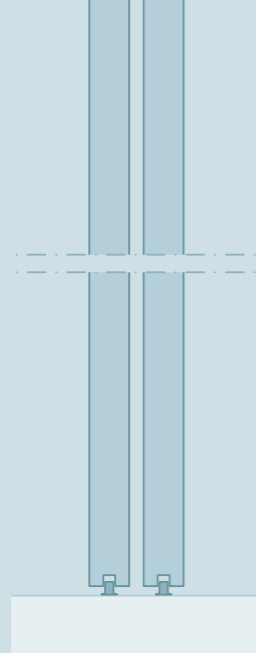
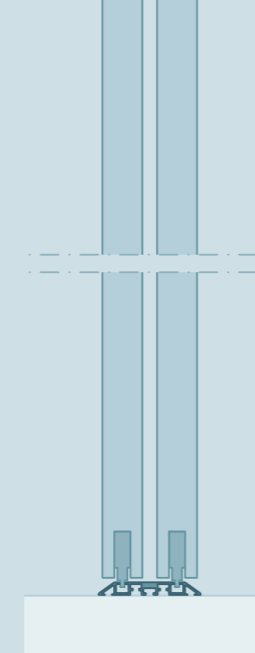
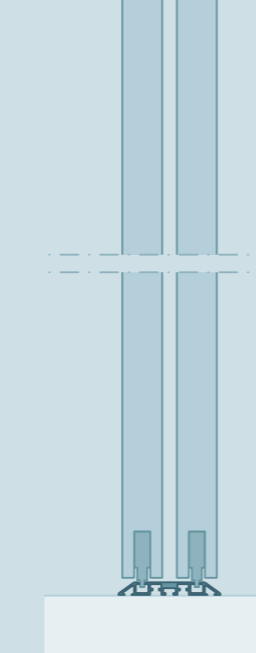
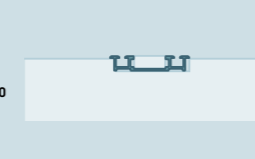
## Albed rail systems

### Combinazioni sistemi binario / Rail systems combinations

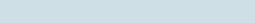
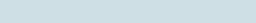
SISTEMA BINARIO EVO EVO RAIL SYSTEM	SISTEMA BINARIO IBRIDO EVO + UNO UNO + EVO HYBRID RAIL SYSTEM	SISTEMA BINARIO UNO UNO RAIL SYSTEM
<b>Binario Evo a parete</b> Wall Evo rail 	<b>Binario Evo a parete</b> Wall Evo rail 	
<b>Binario Evo a soffitto con trave da incasso</b> Ceiling Evo rail with built-in system 	<b>Binario Evo a soffitto con trave da incasso</b> Ceiling Evo rail with built-in system 	<b>Binario Uno a soffitto incassato</b> Built-in ceiling Uno rail 
<b>Binario Evo a soffitto</b> Ceiling Evo rail 	<b>Binario Evo a soffitto</b> Ceiling Evo rail 	<b>Binario Uno a soffitto</b> Ceiling Uno rail 
		
	<b>Binario Uno a pavimento</b> Floor Uno rail 	<b>Binario Uno a pavimento</b> Floor Uno rail 
	<b>Binario Uno a pavimento incassato</b> Built-in floor Uno rail 	<b>Binario Uno a pavimento incassato</b> Built-in floor Uno rail 
	<b>Binario Uno a pavimento incassato con inserto in alluminio</b> Built-in floor Uno rail with aluminium insert 	<b>Binario Uno a pavimento incassato con inserto in alluminio</b> Built-in floor Uno rail with aluminium insert 

### Sistema binario Evo / Evo rail system

#### BINARIO SUPERIORE / UPPER RAIL

Tipologia binario Rail type	1 via 1 way	2 vie 2 ways	3 vie 3 ways	1 via 1 way	2 vie 2 ways	3 vie 3 ways
<b>Binario Evo a soffitto</b> Ceiling Evo rail	€/ml 110	€/ml 150	€/ml 260	EQ-BS1	EQ-BS2	EQ-BS3
<b>Binario Evo a parete</b> Wall Evo rail	€/ml 130	€/ml 180	-	EQ-BP1	EQ-BP2	-

#### ACCESSORI SISTEMA BINARIO / RAIL SYSTEM ACCESSORIES

Elemento Element	1 via 1 way	2 vie 2 ways	3 vie 3 ways	1 via 1 way	2 vie 2 ways	3 vie 3 ways
<b>Trave da incasso per binario Evo a soffitto</b> Built-in system for ceiling Evo rail	€/ml 55	€/ml 60	€/ml 130	EQ-TB10	EQ-TB20	EQ-TB30
<b>Coppia di tappi di chiusura per binario Evo a soffitto</b> Pair of plugs to cover the sides of the ceiling Evo rail	€ 80	€ 80	-	EQ-T1	EQ-T2	-
<b>Coppia di tappi di chiusura per binario Evo a parete</b> Pair of plugs to cover the sides of the ceiling Wall rail	€ 80	€ 80	-	EQ-T10	EQ-T20	-
<b>Profilo di battuta (parete perpendicolare al binario)</b> Terminal doorjamb (wall perpendicular to the rail)	€ 190	-	-	QD-ST1	-	-
<b>Profilo di battuta (parete parallela al binario)</b> Terminal doorjamb (wall parallel to the rail)	€ 190	€ 190	-	QD-SP1	QD-SP2	-
<b>Kit-pocket</b> Kit-pocket	€ 190	€ 380	€ 570	EQ-KP1	EQ-KP2	EQ-KP3

#### LAVORAZIONI SPECIALI

Taglio inclinato Angled cutting	Prezzo Price	Codice Code
<b>Taglio ≠ 90° del binario a soffitto</b> Cut ≠ 90° of ceiling rail	€ 60	EQ-TL1
<b>Taglio ≠ 90° della trave da incasso</b> Cut ≠ 90° of built-in system	€ 60	EQ-TL2

### Sistema binario Uno / Uno rail system

#### BINARIO SUPERIORE / UPPER RAIL

Tipologia binario Rail type	1 via 1 way	2 vie 2 ways	3 vie 3 ways	1 via 1 way	2 vie 2 ways	3 vie 3 ways
<b>Binario Uno a soffitto</b> Ceiling Uno rail	€/ml 90	€/ml 90	€/ml 180	VT-S1	VT-S2	VT-S3

#### BINARIO INFERIORE / LOWER RAIL

Tipologia binario Rail type	1 via 1 way	2 vie 2 ways	3 vie 3 ways	1 via 1 way	2 vie 2 ways	3 vie 3 ways
<b>Binario Uno a pavimento</b> Floor Uno rail	€/ml 80	€/ml 80	€/ml 160	VT-P1	VT-P2	VT-P3
<b>Binario Uno a pavimento incassato</b> Built-in floor Uno rail	€/ml 70	€/ml 70	€/ml 140	VT-P10	VT-P20	VT-P30
<b>Binario Uno a pavimento incassato con inserto in alluminio</b> Built-in floor Uno rail with aluminium insert	-	€/ml 90	€/ml 180	-	VT-P40	VT-P50

#### ACCESSORI SISTEMA BINARIO / RAIL SYSTEM ACCESSORIES

Elemento Element	1 via 1 way	2 vie 2 ways	3 vie 3 ways	1 via 1 way	2 vie 2 ways	3 vie 3 ways
<b>Profilo di battuta (parete perpendicolare al binario)</b> Terminal doorjamb (wall perpendicular to the rail)	€ 190	-	-	QD-ST1	-	-
<b>Profilo di battuta (parete parallela al binario)</b> Terminal doorjamb (wall parallel to the rail)	€ 190	€ 190	-	QD-SP1	QD-SP2	-

# Scorrevoli su binario a soffitto

## Sliding panels on ceiling rail

### Pannelli su sistema binario Evo

#### Panels on Evo rail system

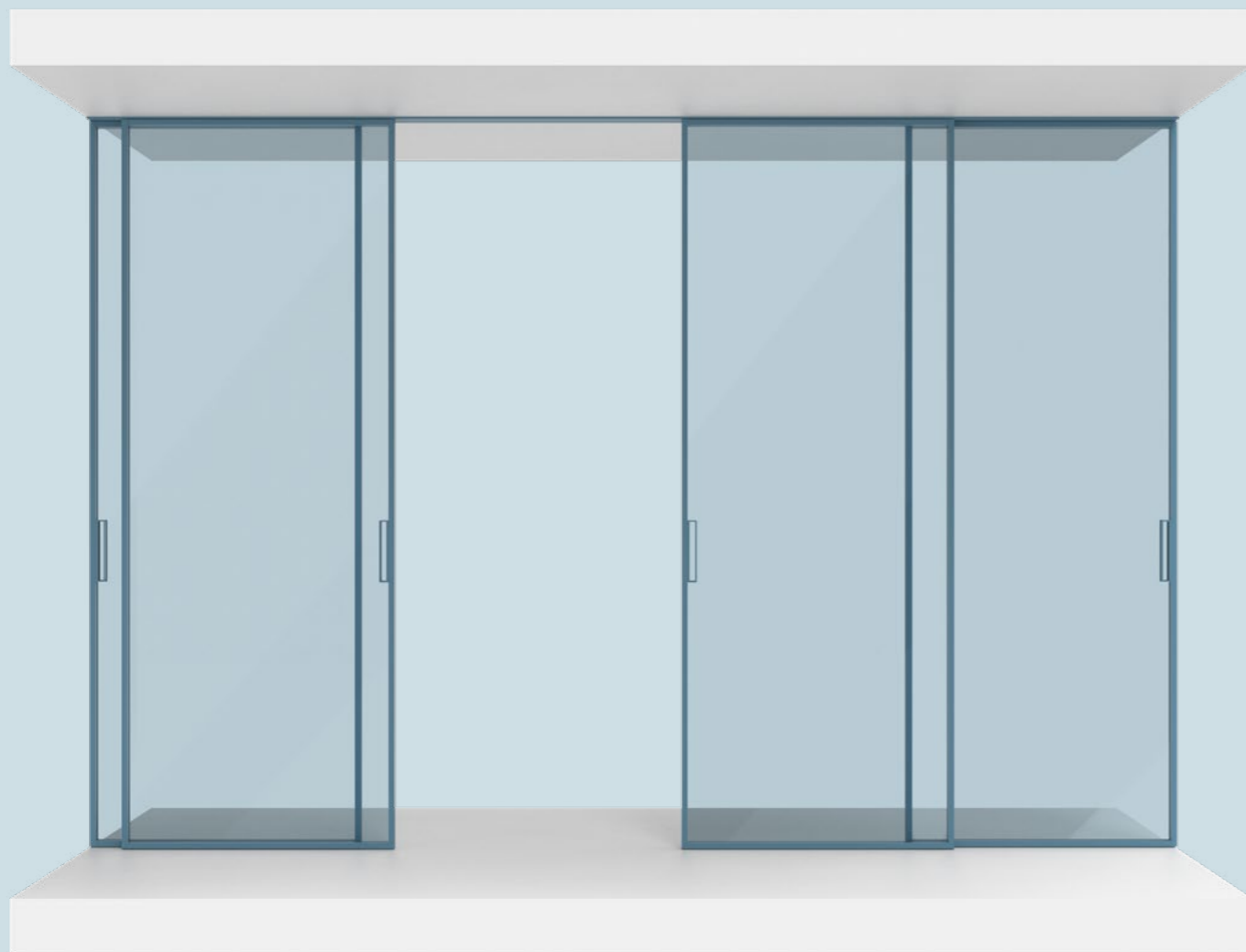

Il "binario a soffitto o incassato" Evo di Albed permette di gestire il movimento dei pannelli scorrevoli con una completa integrazione architettonica. La soluzione incassata prevede una trave che viene posizionata durante la realizzazione dei controsoffitti. Una volta installato, il sistema di scorrimento risulta pressoché invisibile, permettendo di percepire solo un segno sul soffitto. Il binario Evo è dotato di un sistema completo di regolazioni in grado di assicurare una sempre perfetta messa in bolla della linea di scorrimento; è dotato di carrelli con cuscinetti ad alta scorrevolezza e di un sofisticato meccanismo di rallentamento in apertura e chiusura. I pannelli scorrono quindi sospesi a soffitto permettendo di ottenere soluzioni progettuali minimali, nelle quali i pannelli scorrono all'interno dell'architettura senza alcuna presenza a terra o a parete di altri elementi tecnici.

Albed's "ceiling rail or built-in rail" can be used to manage sliding panel movements, with complete architectural integration. The built-in solution provides a beam to be positioned while constructing false ceilings. Once installed, the sliding system is almost invisible, allowing you to see only a mark on the ceiling. The rail provides a complete regulating system that ensures perfect leveling of the sliding line; it is fitted with easy slide bearings and a soft opening and closing mechanism. The panels slide then suspended ceiling allowing to obtain minimal design solutions, in which the panels slide inside the architecture without any presence on the floor or on the wall of other technical elements.

### Binario superiore Evo / Upper Evo rail

P. 234



**Binario Evo a soffitto a 1 via**  
1 way ceiling  
Evo rail

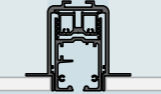

**Binario Evo a soffitto a 1 via con trave da incasso**  
1 way ceiling  
Evo rail with built-in system

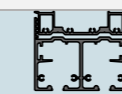

**Binario Evo a soffitto a 2 vie**  
2 ways ceiling  
Evo rail

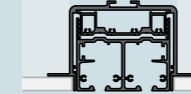

**Binario Evo a soffitto a 2 vie con trave da incasso**  
2 ways ceiling  
Evo rail with built-in system

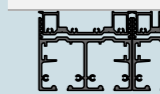

**Binario Evo a soffitto a 3 vie**  
3 ways ceiling  
Evo rail

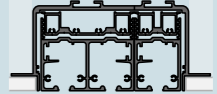

**Binario Evo a soffitto a 3 vie con trave da incasso**  
3 ways ceiling  
Evo rail with built-in system

### Pannelli compatibili / Compatible panels

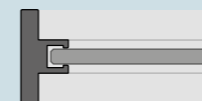

**QUADRA vetro singolo**  
single glass  
P. 246



**QUADRA doppio vetro**  
double glass  
P. 246



**QUADRA pannello**  
panel  
P. 246



**RI-TRAIT vetro**  
glass  
P. 250

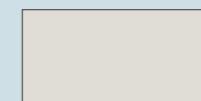

**RI-TRAIT pannello**  
panel  
P. 250

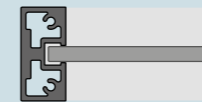

**PRIMA**  
P. 248



**CELINE**  
P. 248



**RI-TRAIT 8B**  
P. 251



**DOT**  
P. 252

# Scorrevoli su binario a soffitto

## Sliding panels on ceiling rail

### Pannelli su sistema binario ibrido Evo+Uno

#### Panels on hybrid rail system Evo+Uno

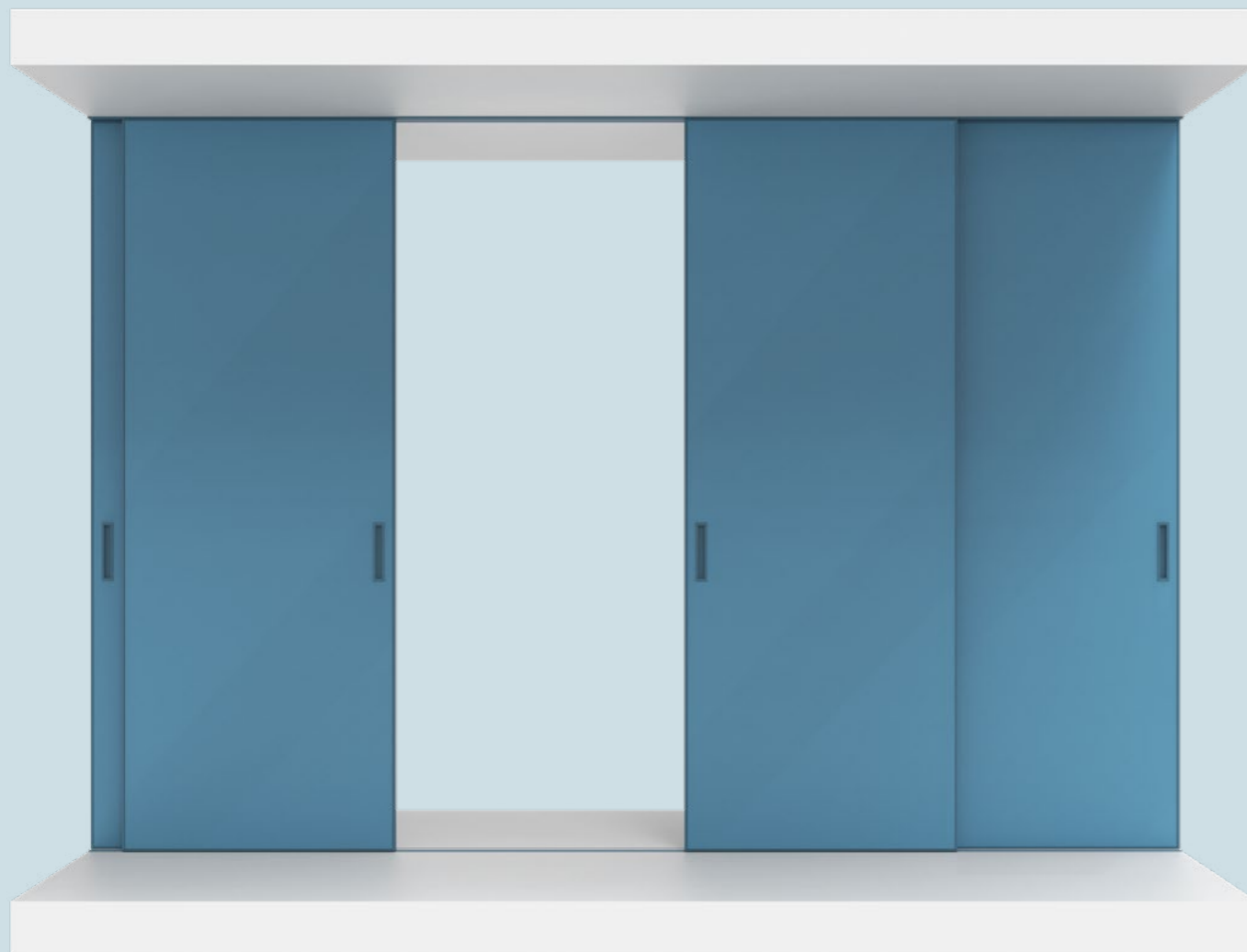

Il "binario a soffitto" "Evo" e il binario inferiore "Uno" di Albed permettono di realizzare installazioni ibride che permettono di gestire il movimento dei pannelli scorrevoli in contesti in cui è necessario tutelare una maggiore linearità di movimento dei pannelli. Questo accade soprattutto in contesti storici in cui sono presenti soffitti o pavimenti "fuori squadra" o quando i pannelli possono essere sottoposti a forti spinte frontali. Utilizzando il binario Evo di Albed i pannelli sono sospesi a soffitto, mentre il binario a pavimento "Uno" funge da guida aggiuntiva allo scorrimento del pannello. Il binario a pavimento è disponibile in diverse soluzioni e finiture, incassato o in appoggio, con o senza inserto in finitura, permettendo di ottimizzare la sua integrazione col progetto.

Albed's "ceiling rail" "Evo" and the lower rail "Uno" allow to realize hybrid installations that allow to manage the movement of the sliding panels in contexts where it is necessary to have a greater linearity of movement of the panels. This happens especially in contexts in which ceilings or floors are crooked or when the panels can be subjected to strong frontal pushes. In the EVO rail the panels are suspended from the ceiling, while the floor rail "ONE" is an additional guide to the sliding of the panel. The floor rail is available in different solutions and finishes, built-in or not, with or without finishing insert, and it allows to optimize its integration with the project.

### Binario superiore Evo / Upper Evo rail

P. 234



**Binario Evo a soffitto a 1 via**  
1 way ceiling  
Evo rail

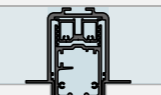

**Binario Evo a soffitto a 1 via con trave da incasso**  
1 way ceiling  
Evo rail with  
built-in system



**Binario Evo a soffitto a 2 vie**  
2 ways ceiling  
Evo rail

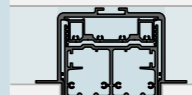

**Binario Evo a soffitto a 2 vie con trave da incasso**  
2 ways ceiling  
Evo rail with  
built-in system

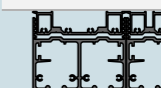

**Binario Evo a soffitto a 3 vie**  
3 ways ceiling  
Evo rail

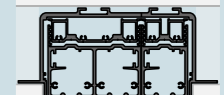

**Binario Evo a soffitto a 3 vie con trave da incasso**  
3 ways ceiling  
Evo rail with  
built-in system

### Pannelli compatibili / Compatible panels

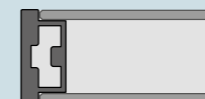

**QUADRA doppio vetro**  
double glass  
P. 246



**QUADRA pannello**  
panel  
P. 246

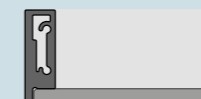

**RI-TRAIT vetro**  
glass  
P. 250

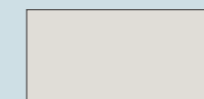

**RI-TRAIT pannello**  
panel  
P. 250



**RI-TRAIT 8B**  
P. 251

### Binario inferiore Uno / Binario inferiore Uno

P. 234



**Binario Uno a pavimento a 2 vie**  
2 ways floor  
Uno rail



**Binario Uno a pavimento a 2 vie incassato**  
2 ways built-in  
floor Uno rail



**Binario Uno a pavimento a 2 vie incassato con inserto in alluminio**  
2 ways built-in floor  
Uno rail with  
aluminium insert



**Binario Uno a pavimento a 3 vie**  
3 ways floor  
Uno rail



**Binario Uno a pavimento a 3 vie incassato**  
3 way built-in  
floor Uno rail



**Binario Uno a pavimento a 3 vie incassato con inserto in alluminio**  
3 ways built-in floor  
Uno rail with  
aluminium insert



# Scorrevoli su binario a soffitto

## Sliding panels on ceiling rail

### Pannelli su sistema binario Uno

#### Panels on Uno rail system



Il "binario a soffitto" Uno di Albed permette di gestire il movimento dei pannelli che scorrono in appoggio al binario a pavimento. Il binario a soffitto ha la sola funzione di guida e di bilanciamento del pannello. Questa soluzione è indicata per contesti architettonici nei quali i soffitti non permettono di sopportare alcun carico. Il binario a pavimento è disponibile in diverse soluzioni e finiture, incassato o in appoggio, con o senza inserto in finitura, permettendo di ottimizzare la sua integrazione col progetto.

Albed's "ceiling rail" Uno allows to manage the movement of the panels that slide on the floor rail. The ceiling rail guides and balances the panel. This solution is recommended for architectural contexts in which the ceilings do not allow to support any weight. The floor rail is available in different solutions and finishes, built-in or not, with or without finishing insert, and it allows to optimize its integration with the project.

### Binario superiore Uno / Upper Uno rail

P. 234



**Binario Uno a soffitto a 2 vie**  
2 ways ceiling Uno rail



**Binario Uno a soffitto a 2 vie incassato**  
2 ways built-in ceiling Uno rail



**Binario Uno a soffitto a 3 vie**  
3 ways ceiling Uno rail



**Binario Uno a soffitto a 3 vie incassato**  
3 ways built-in ceiling Uno rail

### Pannelli compatibili / Compatible panels

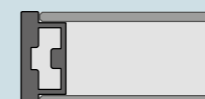

**QUADRA doppio vetro**  
double glass  
P. 246



**QUADRA pannello**  
panel  
P. 246



**RI-TRAIT vetro**  
glass  
P. 250

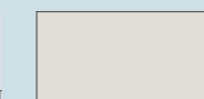

**RI-TRAIT pannello**  
panel  
P. 250



**RI-TRAIT 8B**  
P. 251

### Binario inferiore Uno / Lower Uno rail

P. 234

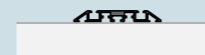

**Binario Uno a pavimento a 2 vie**  
2 ways floor Uno rail



**Binario Uno a pavimento a 2 vie incassato**  
2 ways built-in floor Uno rail



**Binario Uno a pavimento a 2 vie incassato con inserto in alluminio**  
2 ways built-in floor Uno rail with aluminium insert



**Binario Uno a pavimento a 3 vie**  
3 ways floor Uno rail



**Binario Uno a pavimento a 3 vie incassato**  
3 way built-in floor Uno rail



**Binario Uno a pavimento a 3 vie incassato con inserto in alluminio**  
3 ways built-in floor Uno rail with aluminium insert

# Scorrevoli su binario a parete

## Sliding panels on wall rail

### Pannelli su sistema binario Evo

#### Panels on Evo rail system

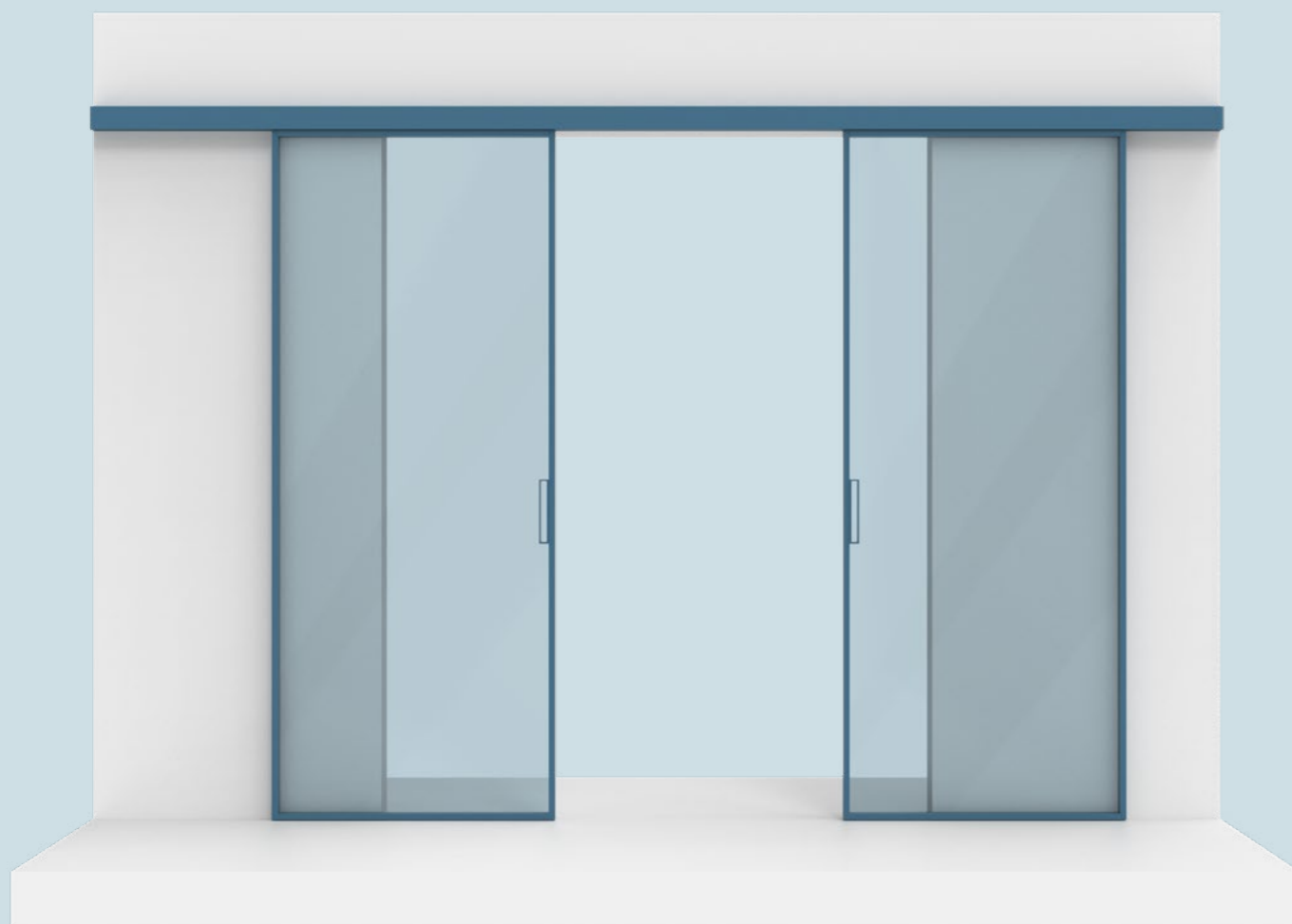

Il "binario a parete" Evo di Albed permette di gestire il movimento dei pannelli scorrevoli, con fissaggio sulla sola parete. Questa soluzione risulta completamente invisibile da un lato del varco e presenta un forte pulizia tecnica dal lato dell'installazione. Il binario Evo è dotato di un sistema completo di regolazioni in grado di assicurare una sempre perfetta messa in bolla della linea di scorrimento; è dotato di carrelli con cuscinetti ad alto scorrimento e di un sofisticato meccanismo di rallentamento in apertura e chiusura. I pannelli scorrono quindi sospesi a parete permettendo di ottenere soluzioni progettuali minimali, nelle quali i pannelli scorrono all'interno dell'architettura senza alcuna presenza a terra o a parete di altri elementi tecnici.

Albed's "Wall rail" Evo allows to manage the movement of the sliding panels with mounting on the wall only. This solution is completely invisible on one side and presents a technical cleaning of the side of the installation. The rail provides a complete regulating system that ensures perfect leveling of the sliding line; it is fitted with easy slide bearings and a soft opening and closing mechanism. The panels slide suspended on the wall allowing to obtain minimal design solutions, in which the panels slide inside the architecture without any presence on the floor or on the wall of other technical elements.

### Binario superiore Evo / Upper Evo rail

P. 234



**Binario Evo  
a parete a 1 via**  
1 way wall  
Evo rail



**Binario Evo  
a parete a 2 vie**  
2 ways wall  
Evo rail

### Pannelli compatibili / Compatible panels

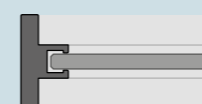

**QUADRA  
vetro singolo**  
single glass  
P. 246



**QUADRA  
doppio vetro**  
double glass  
P. 246



**QUADRA  
pannello**  
panel  
P. 246



**RI-TRAIT  
vetro**  
glass  
P. 250

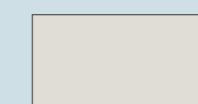

**RI-TRAIT  
pannello**  
panel  
P. 250



**PRIMA**  
P. 248



**CELINE**  
P. 249



**RI-TRAIT 8B**  
P. 251



**DOT**  
P. 252

# Girevoli su binario a soffitto

## Pivoting panels on ceiling rail

### Girevoli su sistema binario Evo

#### Pivoting on Evo rail system



Il "binario a soffitto o incassato" Evo di Albed permette il posizionamento di pannelli girevoli. I pannelli girevoli sono una soluzione dinamica per delimitare gli spazi. Consistono in uno o più pannelli in alluminio e vetro, oppure in legno, che ruotano su un proprio asse (simmetrico o asimmetrico). L'utilizzo del binario Evo e delle soluzioni di movimento progettate e realizzate da Albed, permettono di ottenere soluzioni progettuali minimali, nelle quali i pannelli ruotano all'interno dell'architettura senza alcuna presenza a terra o a parete di elementi tecnici.

Albed's "ceiling rail or built-in rail" EVO allows the positioning of the revolving panels. The revolving panels are a dynamic solution to delimit spaces. They are one or more panels in aluminium and glass or in wood that rotate on their own axis (symmetrical or asymmetrical). The use of the rail EVO and the moving solutions designed and built by Albed, allow to obtain minimal design solutions in which the panels rotate within the architecture without any presence on the floor or on the wall of technical elements.

### Binario superiore Evo / Upper Evo rail

P. 234



**Binario Evo  
a soffitto a 1 via**  
1 way ceiling  
Evo rail

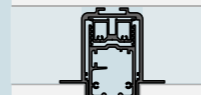

**Binario Evo  
a soffitto a 1 via con  
trave da incasso**  
1 way ceiling  
Evo rail with  
built-in system

### Pannelli compatibili / Compatible panels



**QUADRA  
vetro singolo**  
single glass  
P. 246

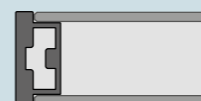

**QUADRA  
doppio vetro**  
double glass  
P. 246

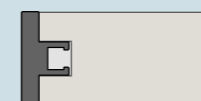

**QUADRA  
pannello**  
panel  
P. 246



**RI-TRAIT  
vetro**  
glass  
P. 250

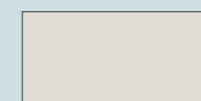

**RI-TRAIT  
pannello**  
panel  
P. 250



**PRIMA**  
P. 248



**CELINE**  
P. 251



**RI-TRAIT 8B**  
P. 251

# Quadra scorrevole o girevole

## Sliding or pivoting Quadra

### 1 PANNELLI QUADRA SCORREVOLI\* O GIREVOLI

#### QUADRA SLIDING\* OR PIVOTING PANELS

\*per pannelli compatibili con sistema binario Uno consultare tab. 4  
\*for panels compatible with One rail system consult tab. 4

\*\*necessario aggiungere "coppia di tiranti radrizzanti" P. 135  
\*\*it is necessary to add a "pair of straightening rods" P.135

Tipo pannello	Finitura base		L 500 - L 700	L 700 - L 900	L 900 - L 1100	L 1100 - L 1300	L 1300 - L 1500
Vetro singolo Single glass	Vetro Cat. A Glass Cat. A	H < 2100	€ 1.082	€ 1.171	€ 1.260	€ 1.348	€ 1.417
		H 2100 - H 2300	€ 1.118	€ 1.214	€ 1.309	€ 1.404	€ 1.491
		H 2300 - H 2500	€ 1.155	€ 1.257	€ 1.359	€ 1.460	€ 1.539
		H 2500 - H 2700	€ 1.191	€ 1.300	€ 1.408	€ 1.490	€ 1.599
		H 2700 - H 3000	€ 1.246	€ 1.364	€ 1.469	€ 1.511	€ 1.625
Doppio vetro Double Glass	Vetro opaco cat. C Opaque lass Cat. C	H < 2100	€ 1.665	€ 1.917	€ 2.168	€ 2.420	€ 2.672
		H 2100 - H 2300	€ 1.752	€ 2.024	€ 2.297	€ 2.569	€ 2.840
		H 2300 - H 2500	€ 1.839	€ 2.132	€ 2.425	€ 2.718	€ 3.008
		H 2500 - H 2700	€ 1.925	€ 2.239	€ 2.553	€ 2.867	€ 3.176
		H 2700 - H 3000	€ 2.055	€ 2.400	€ 3.082	€ 3.091	€ 3.429
Pannello legno Wooden panel	Laccato standard Standard lacquered	H < 2100	€ 965	€ 1.090	€ 1.220	€ 1.490	-
		H 2100 - H 2300	€ 1.060	€ 1.230	€ 1.384	€ 1.654	-
		H 2300 - H 2500	€ 1.240	€ 1.376	€ 1.548	€ 1.820	-
		H 2500 - H 2700*	€ 1.240	€ 1.376	€ 1.548	€ 1.820	-
		H 2700 - H 3000	€ 1.390	€ 1.550	€ 1.690	€ 1.990	-
Pannello cuoio Leather panel	Cuoio rigenerato Regenerated Leather	H < 2100	€ 2.136	€ 2.267	€ 2.398	€ 2.752	-
		H 2100 - H 2300	€ 2.215	€ 2.346	€ 2.477	€ 2.883	-
		H 2300 - H 2500	€ 2.555	€ 2.686	€ 2.817	€ 3.014	-
		H 2500 - H 2700**	€ 2.621	€ 2.752	€ 2.883	€ 3.211	-
		H 2700 - H 3000	€ 2.686	€ 2.817	€ 2.949	€ 3.342	-

### 2 FINITURE / FINISHINGS

Tipo pannello	Finitura	P. 30					
Vetro singolo Single glass	Vetro Cat. B / Glass Cat. B		+ 13%	+ 15%	+ 16%	+ 17%	+ 19%
	Vetro Cat. C / Glass Cat. C		+ 19%	+ 24%	+ 27%	+ 27%	+ 30%
	Vetro Cat. D / Glass Cat. D		+ 40%	+ 50%	+ 58%	+ 58%	+ 65%
	Vetro Cat. E / Glass Cat. E		+ 65%	+ 95%	+ 95%	+ 95%	+ 105%
	Doppio vetro Double Glass	Vetro opaco cat. D / Opaque glass Cat. D		+ 3%	+ 3%	+ 5%	+ 5%
Pannello legno Wooden panel	Essenza legno / Wood essence		+ € 270	+ € 270	+ € 270	+ € 270	-
	Laccato custom RAL / Custom RAL lacquered		+ € 200	+ € 200	+ € 200	+ € 200	-
Pannello cuoio Leather pane	Cuoio / Leather		+ 40%	+ 40%	+ 40%	+ 35%	-

### 3 PERSONALIZZAZIONI / PERSONALIZATION

Tipo pannello	Divisioni vetro		Tipo pannello	Kit di scorrimento	
Vetro singolo Single glass	2 divisioni / 2 divisions [2]	+ € 60	Doppio vetro e pannelli Double glass and panels	Kit carrello per binario inferiore Uno Sliding runner kit for floor Uno rail	+ € 180
	3 divisioni / 3 divisions [3]	+ € 120			
	8 divisioni / 8 divisions [4]	+ € 185			

### 4 SISTEMA BINARIO UNO / UNO RAIL SYSTEM

### 5 MANIGLIE / HANDLES

Tipo pannello	Tipologia di apertura	Maniglia	Solo maniglia	Chiave Patent	Nottolino
Vetro singolo Single glass	Pannello scorrevole Sliding panel	Loira	+ € 150	+ € 250**	+ € 250**
		Adige 100mm	+ € 100	-	-
	Adige 300mm	+ € 200	-	-	
	Pannello pivotante* Pivoting panel*	Adige 100mm	+ € 100	-	-
Adige 300mm	+ € 200	-	-		
Altri pannelli Other panels	Pannello scorrevole o pannello pivotante* Sliding panel or pivoting panel*	Piave	+ € 100	+ € 200**	+ € 200**

\*per pannelli pivotanti è possibile ordinare 0, 1 o 2 maniglie.  
In caso di 1 maniglia specificare se posizionarla a destra o a sinistra  
\*for pivoting panels it is possible to order 0, 1 or 2 handles.  
In case of 1 handle, specify to position it on the right or on the left

\*\*opzione disponibile solo per pannello scorrevole,  
necessita di un profilo di battuta con incontro  
\*\*option only available for sliding panel,  
requires terminal doorjamb with striker

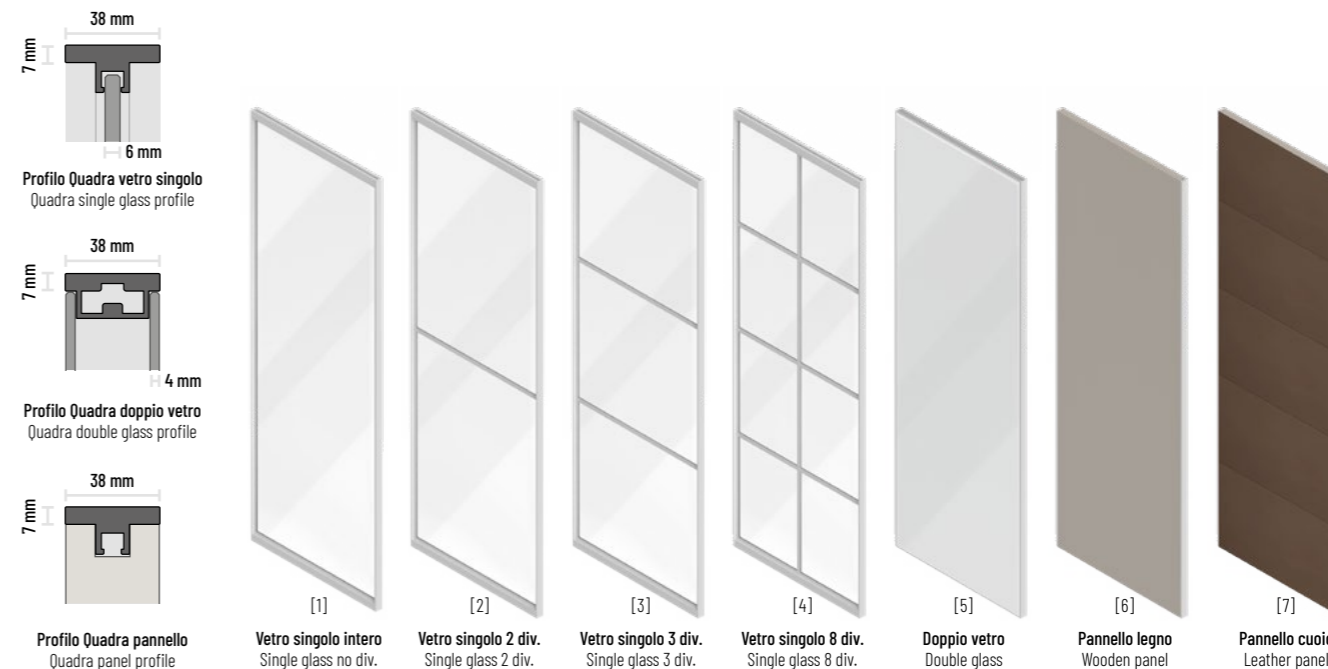

### CODICI PORTE / DOORS CODES

Tipo pannello Panel type	Scorrevole / Sliding			Girevole / Pivoting
	Sistema binario Evo Evo rail system	Sistema binario Uno Uno rail system	Binario All Ways All Ways rail	Sistema binario Evo Evo rail system
[1]	QD-A1	-	QD-A1W	QD-A1P
[2]	QD-A2	-	QD-A2W	QD-A2P
[3]	QD-A3	-	QD-A3W	QD-A3P
[4]	QD-A8	-	QD-A8W	QD-A8P
[5]	QD-V2	QD-V2U	QD-V2W	QD-V2P
[6]	QD-L1	QD-L1U	QD-L1W	QD-L1P
[7]	QD-C05	QD-C05U	QD-C05W	QD-C05P

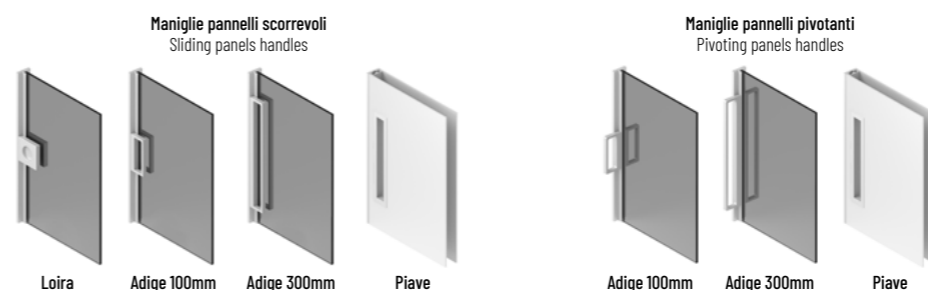

### CODICI MANIGLIE / HANDLES CODES

Maniglia Handle	Solo maniglia Only handle	Chiave Patent Patent key	Nottolino Latch free/busy
Loira	A1	A2	A3
Adige 100mm*	R	-	-
Adige 300mm*	R2	-	-
Piave*	Q	Q1	Q2
Adige 100mm**	RX	-	-
Adige 300mm**	R2X	-	-
Piave**	QX	-	-

\*maniglia per pannelli scorrevoli / handle for sliding panel  
\*\*maniglia per pannelli girevoli / handle for pivoting panel



# Ri-trait scorrevole o girevole

## Sliding or pivoting Ri-trait

### 1 PANNELLI RI-TRAIT SCORREVOLI\* O GIREVOLI

RI-TRAIT SLIDING\* OR PIVOTING PANELS\* FOR EVO

\* per pannelli compatibili con sistema binario Uno consultare tab. 3  
\* for panels compatible with One rail system consult tab. 3

Tipo pannello	Finitura base	L 500 - L 700	L 700 - L 900	L 900 - L 1100	L 1100 - L 1300	L 1300 - L 1500	
Vetro	Vetro Cat. A Glass Cat. A	H < 2100	€ 1.073	€ 1.190	€ 1.307	€ 1.425	€ 1.542
		H 2100 - H 2300	€ 1.120	€ 1.247	€ 1.374	€ 1.501	€ 1.626
		H 2300 - H 2500	€ 1.167	€ 1.303	€ 1.440	€ 1.577	€ 1.710
		H 2500 - H 2700	€ 1.213	€ 1.360	€ 1.506	€ 1.653	€ 1.794
		H 2700 - H 3000	€ 1.283	€ 1.445	€ 1.606	€ 1.767	€ 1.910
Pannello legno	Laccato standard Standard lacquered	H < 2100	€ 865	€ 990	€ 1.120	€ 1.190	-
		H 2100 - H 2300	€ 960	€ 1.130	€ 1.284	€ 1.354	-
		H 2300 - H 2500	€ 1.090	€ 1.226	€ 1.398	€ 1.470	-
		H 2500 - H 2700	€ 1.140	€ 1.276	€ 1.448	€ 1.520	-
		H 2700 - H 3000**	€ 1.240	€ 1.390	€ 1.540	€ 1.640	-

### 2 FINITURE / FINISHINGS

Tipo pannello	Finitura	P. 30				
Vetro	Vetro Cat. B / Glass Cat. B		+ 10%	+ 10%	+ 10%	+ 10%
	Vetro Cat. C / Glass Cat. C		+ 20%	+ 20%	+ 28%	+ 28%
	Vetro Cat. D / Glass Cat. D		+ 30%	+ 30%	+ 40%	+ 45%
	Vetro Cat. E / Glass Cat. E		+ 65%	+ 95%	+ 95%	+ 105%
Pannello legno	Essenza legno / Wood essence		+ € 270	+ € 270	+ € 270	-
	Laccato custom RAL / Custom RAL lacquered		+ € 200	+ € 200	+ € 200	-

### 3 SISTEMA BINARIO UNO / UNO RAIL SYSTEM

Tipo pannello	Kit di scorrimento	
Vetro	Kit carrello per binario inferiore Uno	+ € 180

### 4 MANIGLIE / HANDLES

Tipo pannello	Tipologia di apertura	Maniglia	Solo maniglia	Chiave Patent	Nottolino
Vetro	Pannello scorrevole o pivotante*	Piave	+ € 100	+ € 200 **	+ € 200 **
		Triennale	+ € 100	-	-
		Loira tonda	+ € 150	+ € 250 **	+ € 250 **
Pannello legno	Pannello scorrevole	Loira quadrata	+ € 150	+ € 250 **	+ € 250 **
		Piave	+ € 100	+ € 200 **	+ € 200 **
		Pannello pivotante*	Piave	+ € 100	-

\*\*necessario aggiungere "coppia di tiranti radrizzanti" P. 135  
\*\* it is necessary to add a "pair of straightening rods" P.135

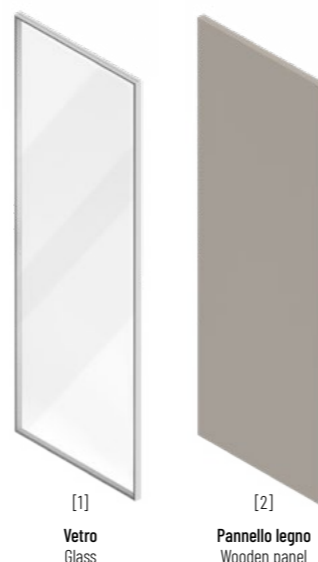
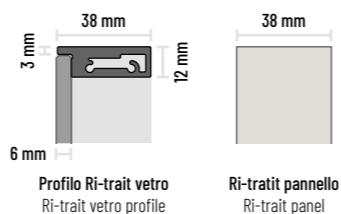

# Ri-trait 8b scorrevole o girevole

## Sliding or pivoting Ri-trait 8b

### 1 PANNELLI RI-TRAIT 8B SCORREVOLI\* O GIREVOLI

RI-TRAIT 8B SLIDING\* OR PIVOTING PANELS

\* per pannelli compatibili con sistema binario Uno consultare tab. 3  
\* for panels compatible with One rail system consult tab. 3

Tipo pannello	Finitura base	L 500 - L 700	L 700 - L 900	L 900 - L 1100	L 1100 - L 1300	L 1300 - L 1500	
Vetro	Vetro Cat. A Glass Cat. A	H < 2100	€ 1.688	€ 1.908	€ 2.093	€ 2.290	€ 2.463
		H 2100 - H 2300	€ 1.750	€ 1.990	€ 2.190	€ 2.396	€ 2.648
		H 2300 - H 2500	€ 1.850	€ 2.089	€ 2.301	€ 2.566	€ 2.746
		H 2500 - H 2700	€ 1.890	€ 2.168	€ 2.399	€ 2.695	€ 2.855
		H 2700 - H 3000	€ 1.990	€ 2.265	€ 2.490	€ 2.790	€ 2.998
Pannello legno	Laccato standard Standard lacquered	H < 2100	€ 865	€ 990	€ 1.120	€ 1.190	-
		H 2100 - H 2300	€ 960	€ 1.130	€ 1.284	€ 1.354	-
		H 2300 - H 2500	€ 1.090	€ 1.226	€ 1.398	€ 1.470	-
		H 2500 - H 2700	€ 1.140	€ 1.276	€ 1.448	€ 1.520	-
		H 2700 - H 3000**	€ 1.240	€ 1.390	€ 1.540	€ 1.640	-

### 2 FINITURE / FINISHINGS

Tipo pannello	Finitura	P. 30				
Vetro	Vetro Cat. B / Glass Cat. B		+ 5%	+ 7%	+ 7%	+ 10%
	Vetro Cat. C / Glass Cat. C		+ 10%	+ 12%	+ 15%	+ 20%
	Vetro Cat. D / Glass Cat. D		+ 15%	+ 20%	+ 25%	+ 30%
	Vetro Cat. E / Glass Cat. E		+ 65%	+ 95%	+ 95%	+ 105%
Pannello legno	Essenza legno / Wood essence		+ € 270	+ € 270	+ € 270	-
	Laccato custom RAL / Custom RAL lacquered		+ € 200	+ € 200	+ € 200	-

### 3 SISTEMA BINARIO UNO / UNO RAIL SYSTEM

Tipo pannello	Kit di scorrimento	
Vetro	Kit carrello per binario inferiore Uno	+ € 180

### 4 MANIGLIE / HANDLES

Tipo pannello	Tipologia di apertura	Maniglia	Solo maniglia	Chiave Patent	Nottolino
Vetro	Pannello scorrevole	Reno	+ € 150	-	-
		Loira	+ € 150	+ € 250 **	+ € 250 **
		Triennale	+ € 100	-	-
Pannello pivotante*	Triennale	Adige 200mm	+ € 100	-	-
		Triennale	+ € 100	-	-

\*per pannelli pivotanti è possibile ordinare 0, 1 o 2 maniglie. In caso di 1 maniglia specificare se posizionarla a destra o a sinistra  
\*for pivoting panels it is possible to order 0, 1 or 2 handles. In case of 1 handle, specify to position it on the right or on the left  
\*\*opzione disponibile solo per pannello scorrevole, necessita di un profilo di battuta con incontro  
\*\*option only available for sliding panel, requires terminal doorjamb with striker

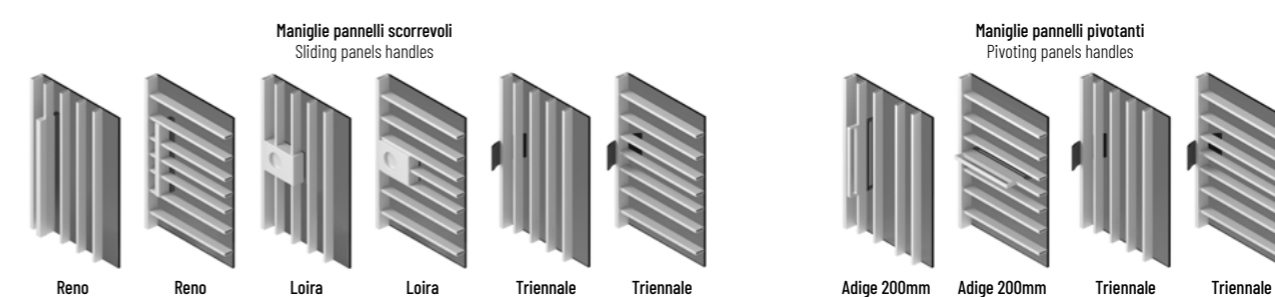

### CODICI PORTE / DOORS CODES

Tipo pannello	Scorrevole / Sliding			Girevole / Pivoting
	Sist binario Evo	Sist. binario Uno	Binario All Ways	Sistema binario Evo
[1]	TR-8BV-R	TR-8BV-RU	TR-8BV-RW	TR-8BV-RP
[2]	TR-8BH-R	TR-8BH-RU	TR-8BH-RW	TR-8BH-RP

### CODICI MANIGLIE / HANDLES CODES

Maniglia	Solo maniglia	Chiave Patent	Nottolino
Reno verticale / vertical	K2	-	-
Reno orizzontale / horizontal	K1	-	-
Loira	RT1	RT2	RT3
Triennale	TR1	-	-
Adige 200	MX	-	-

### Maniglie pannelli scorrevoli

Sliding panels handles

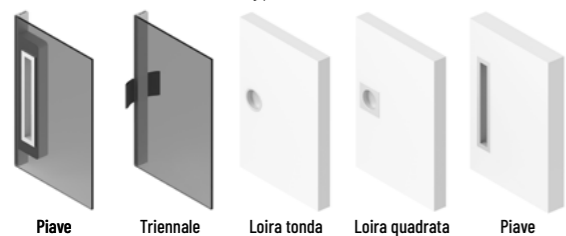

### Maniglie pannelli pivotanti

Pivoting panels handles

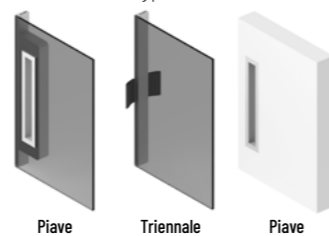

### CODICI PORTE / DOORS CODES

Tipo pannello	Scorrevole / Sliding			Girevole / Pivoting
	Sist binario Evo	Sist. binario Uno	Binario All Ways	Sistema binario Evo
[1]	TR-A1	TR-A1U	TR-A1W	TR-A1P
[2]	TR-L1	TR-L1U	TR-L1W	TR-L1P

\* maniglia per pannelli scorrevoli / handle for sliding panel

\*\* maniglia per pannelli girevoli / handle for pivoting panel

\*\*\* disponibile in finitura cromo satinato o lucido / available in satin or polished chrome finishing

### CODICI MANIGLIE / HANDLES CODES

Maniglia	Solo maniglia	Chiave Patent	Nottolino
Piave*	Q	Q1	Q2
Triennale	TR1	-	-
Loira tonda***	V1	V2	V3
Loira quadrata***	V5	V5	V6
Piave**	QX	-	-

# Dot scorrevole

## Sliding Dot

### 1 PANNELLI DOT SCORREVOLI DOT SLIDING PANELS

Tipo pannello Panel type	Finitura base Base finishing		L 500 - L 700	L 700 - L 900	L 900 - L 1100	L 1100 - L 1300	L 1300 - L 1500
Vetro Glass	Vetro Cat. A Glass Cat. A	H < 2100	€ 815	€ 910	€ 1.004	€ 1.099	€ 1.193
		H 2100 - H 2300	€ 847	€ 950	€ 1.054	€ 1.157	€ 1.261
		H 2300 - H 2500	€ 878	€ 991	€ 1.103	€ 1.216	€ 1.328
	Finitura alluminio anodizzato / Anodized aluminum finishing	H 2500 - H 2700	€ 910	€ 1.031	€ 1.153	€ 1.274	€ 1.396
		H 2700 - H 3000	€ 957	€ 1.092	€ 1.235	€ 1.362	€ 1.470
		H 3000 - H 3200	€ 926	€ 1.190	€ 1.276	-	-

### 2 FINITURE / FINISHINGS

Tipo pannello Panel type	Finitura Finishing	P. 30					
Vetro Glass	Vetro cat. B Glass cat. B		+ 15%	+ 15%	+ 15%	+ 20%	+ 20%
	Vetro cat. C Glass cat. C		+ 30%	+ 30%	+ 35%	+ 40%	+ 40%

### 3 MANIGLIE / HANDLES

Tipo pannello Panel type	Maniglia Handle	Solo maniglia Only handle	Chiave Patent Patent key	Nottolino Latch free/busy
Vetro Glass	Reno 1000mm	+ € 100	-	-
	Reno 1600mm	+ € 150	-	-
	Ticino 400mm	+ € 100	-	-
	Ticino 1600mm	+ € 150	-	-
	Arno 600mm	+ € 150	-	-
	Arno 1600mm	+ € 250	-	-
	Tevere	+ € 150	+ € 250 **	+ € 250 **

\*\*opzione disponibile solo per pannello scorrevole, necessita di un profilo di battuta con incontro  
\*\*option only available for sliding panel, requires terminal doorjamb with striker

8 mm

Dot vetro  
Glass DotVetro  
Glass

#### Maniglie pannelli scorrevoli Sliding panels handles

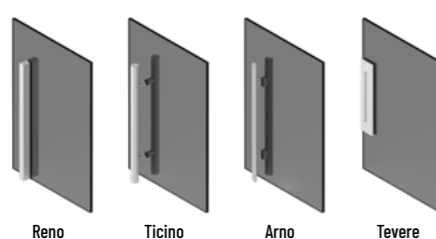

#### CODICI PORTE / DOORS CODES

Tipo pannello Panel type	Scorrevole / Sliding	
	Sist. binario EVO EVO rail system	Sist. binario AW AW rail system
Vetro singolo / Single glass	DT-A1	DT-A1W

#### CODICI MANIGLIE / HANDLES CODES

Maniglia Handle	Solo maniglia Only handle	Chiave Patent Patent key	Nottolino Latch free/busy
Reno 1600mm	H1	-	-
Reno 1000mm	H	-	-
Arno 1600mm	S2	-	-
Arno 600mm	S	-	-
Ticino 1600mm	T1	-	-
Ticino 400mm	T	-	-
Tevere	I	U	Z

# Scorrevoli su binario a soffitto

## Sliding panels on ceiling rail

### Soffietto su sistema binario Evo

#### Folding panels on Evo rail system

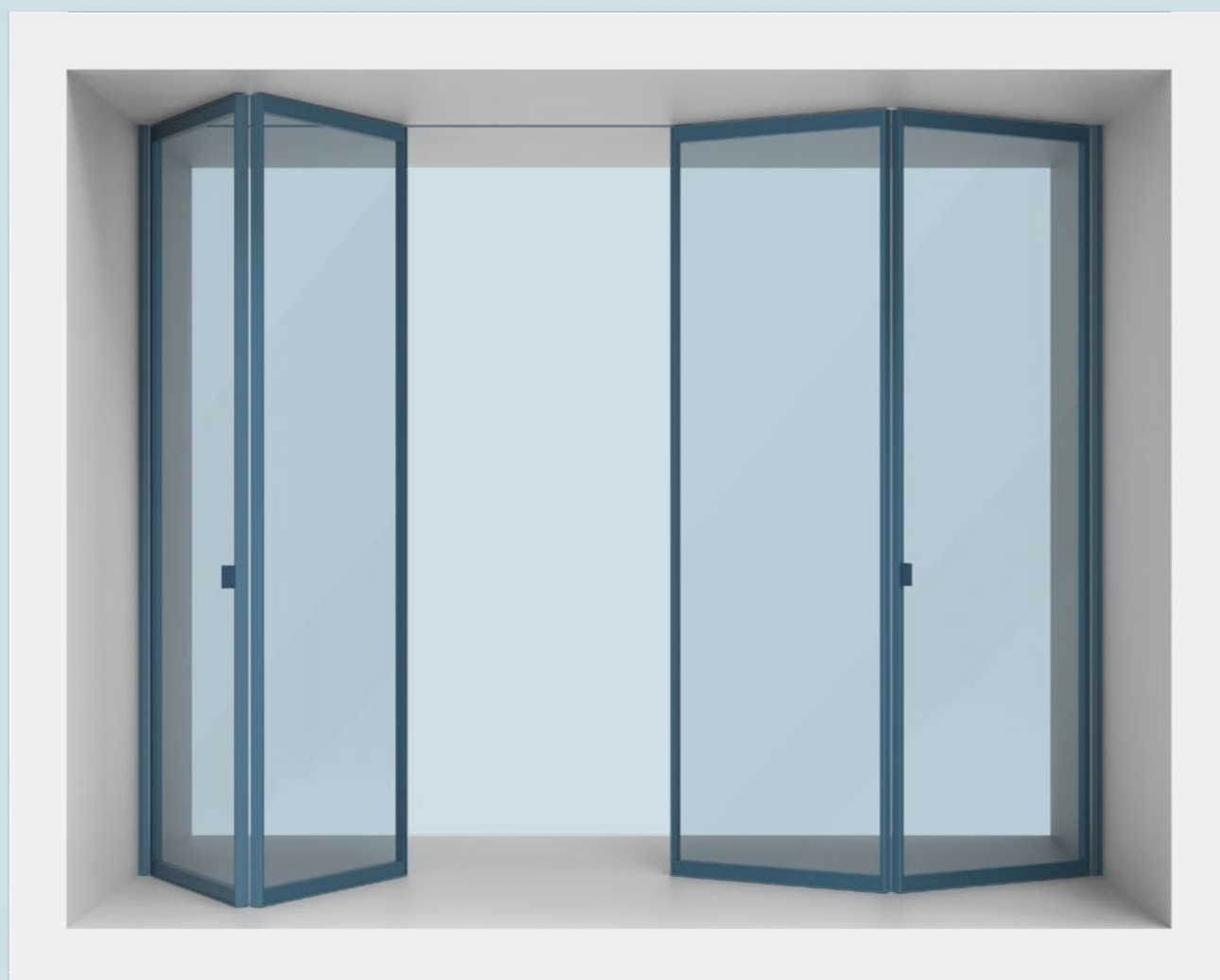

Il "binario a soffitto o incassato" Evo di Albed permette l'installazione anche di pannelli con apertura "a soffietto". Questi pannelli hanno la caratteristica di ripiegarsi su stessi in fase di apertura del varco, abbattendo l'ingombro dei pannelli, permettendo di ottenere luci di passaggio più ampie. Il binario Evo è dotato di un sistema completo di regolazioni in grado di assicurare una sempre perfetta messa in bolla della linea di scorrimento; è dotato di carrelli con cuscinetti ad alto scorrimento e di un sofisticato meccanismo di rallentamento in apertura e chiusura. I pannelli scorrono quindi sospesi a soffitto permettendo di ottenere soluzioni progettuali minimali, nelle quali i pannelli scorrono all'interno dell'architettura senza alcuna presenza a terra o a parete di altri elementi tecnici.

Albed's "ceiling rail or built-in rail" EVO allows the installation of panels with "folding" opening. These panels fold back on themselves during the opening of the passage, reducing the encumbrance of the panels, allowing to have a wider passage. The rail provides a complete regulating system that ensures perfect leveling of the sliding line; it is fitted with easy slide bearings and a soft opening and closing mechanism. The panels slide then suspended ceiling allowing to obtain minimal design solutions, in which the panels slide inside the architecture without any presence on the floor or on the wall of other technical elements.

### Binario superiore Evo / Upper Evo rail

P. 233



**Binario Evo  
a soffitto a 1 via**  
1 way ceiling  
Evo rail



**Binario Evo  
a soffitto a 1 via con  
trave da incasso**  
1 way ceiling  
Evo rail with  
built-in system

### Pannelli compatibili / Compatible panels

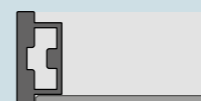

**QUADRA  
SOFFIETTO**  
vetro singolo  
single glass  
P. 256

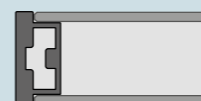

**QUADRA  
SOFFIETTO**  
doppio vetro  
double glass  
P. 256

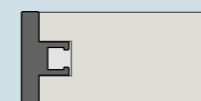

**QUADRA  
SOFFIETTO**  
pannello  
panel  
P. 256

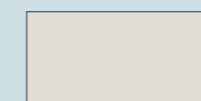

**RI-TRAIT  
SOFFIETTO**  
pannello  
panel  
P. 257



# Quadra soffietto

## Folding Quadra

### 1 PANNELLI QUADRA SOFFIETTO

#### QUADRA FOLDING PANELS

Tipo pannello Panel type	Finitura base Base finishing	L 800 - L 1000	L 1000 - L 1400	L 1400 - L 1800	
Vetro singolo Single glass	Vetro Cat. A Glass Cat. A Finitura alluminio anodizzato / Anodized aluminum finishing [1]	H < 2100	€ 1.912	€ 2.146	€ 2.380
		H 2100 - H 2300	€ 1.986	€ 2.240	€ 2.494
		H 2300 - H 2500	€ 2.062	€ 2.334	€ 2.606
		H 2500 - H 2700	€ 2.132	€ 2.426	€ 2.720
		H 2700 - H 3000	€ 2.242	€ 2.566	€ 2.890
Doppio vetro Double Glass	Vetro opaco Cat. C Opaque glass Cat. C Finitura alluminio anodizzato / Anodized aluminum finishing [2]	H < 2100	€ 2.826	€ 3.330	€ 3.834
		H 2100 - H 2300	€ 2.960	€ 3.504	€ 4.048
		H 2300 - H 2500	€ 3.092	€ 3.678	€ 4.264
Pannello legno Wooden panel	Laccato standard Standard lacquered Finitura alluminio anodizzato / Anodized aluminum finishing [3]	H < 2100	€ 1.880	€ 2.130	€ 2.380
		H 2100 - H 2300	€ 1.980	€ 2.320	€ 2.660
		H 2300 - H 2500	€ 2.408	€ 2.680	€ 2.952
Pannello cuoio Leather panel	Cuoio rigenerato Regenerated Leather Finitura alluminio anodizzato / Anodized aluminum finishing [4]	H < 2100	€ 4.010	€ 4.272	€ 4.534
		H 2100 - H 2300	€ 4.168	€ 4.430	€ 4.692
		H 2300 - H 2500	€ 4.848	€ 5.110	€ 5.372
	H 2500 - H 2700	€ 4.980	€ 5.242	€ 5.504	

### 2 FINITURE / FINISHINGS

Tipo pannello Panel type	Finitura Finishing	P. 30
Vetro singolo Single glass	Vetro Cat. B / Glass Cat. B	+ 15%
	Vetro Cat. C / Glass Cat. C	+ 20%
	Vetro Cat. D / Glass Cat. D	+ 40%
Doppio vetro Double Glass	Vetro Cat. E / Glass Cat. E	+ 65%
	Vetro opaco Cat. D / Opaque glass Cat. D	+ 5%
Pannello legno Wooden panel	Vetro traslucido / Translucent glass	+ 7%
	Essenza legno / Wood essence	+ € 270
Pannello cuoio Leather pane	Laccato custom RAL / Custom RAL lacquered	+ € 200
	Cuoio / Leather	+ 40%

### 3 MANIGLIE / HANDLES

Tipo pannello Panel type	Maniglia Handle	Solo maniglia Only handle
Vetro singolo Single glass	Triennale	+ € 300
Altri pannelli Others panels	Piave	+ € 100

### CODICI PORTE / DOORS CODES

Tipo pannello Panel type	Soffietto / Folding
[1]	QD-A1F
[2]	QD-V2F
[3]	QD-L1F
[4]	QD-C05F

### CODICI MANIGLIE / HANDLES CODES

Maniglia Handle	Solo maniglia Only handle
Piave	TR2
Triennale	QX

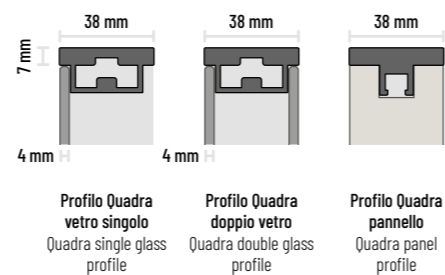

[1]  
Vetro singolo  
Single glass

[2]  
Doppio vetro  
Double glass

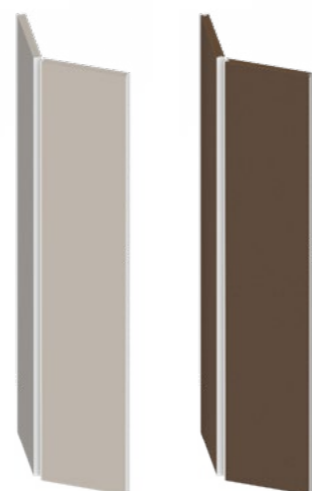

[3]  
Pannello legno  
Wooden panel

[4]  
Pannello cuoio  
Leather panel

### Maniglie pannelli a soffietto

#### Folding panel handles

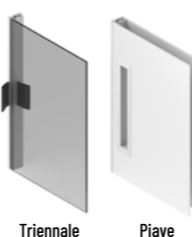

Triennale

Piave

# Ri-trait soffietto

## Folding Ri-trait

### 1 PANNELLI RI-TRAIT SOFFIETTO

#### RI-TRAIT FOLDING PANELS

Tipo pannello Panel type	Finitura base Base finishing	L 800 - L 1000	L 1000 - L 1400	L 1400 - L 1800	
Pannello legno Wooden panel	Laccato standard Standard lacquered	H < 2100	€ 1.680	€ 1.930	€ 2.180
		H 2100 - H 2300	€ 1.780	€ 2.120	€ 2.460
		H 2300 - H 2500	€ 2.008	€ 2.380	€ 2.752
	H 2500 - H 2700	€ 2.108	€ 2.380	€ 2.652	

### 2 FINITURE / FINISHINGS

Tipo pannello Panel type	Finitura Finishing	P. 30
Pannello legno Wooden panel	Essenza legno / Wood essence	+ € 270
	Laccato custom RAL / Custom RAL lacquered	+ € 200

### 3 MANIGLIE / HANDLES

Tipo pannello Panel type	Maniglia Handle	Solo maniglia Only handle
Pannello legno Wooden panel	Piave	+ € 100

### Maniglie pannelli a soffietto

#### Folding panel handles



Piave

### CODICI PORTE / DOORS CODES

Tipo pannello Panel type	Soffietto / Folding
Pannello legno Wooden Panel	Sistema binario EVO EVO rail system TR-L1F

### CODICI MANIGLIE / HANDLES CODES

Maniglia Handle	Solo maniglia Only handle
Piave	QX



Ri-trait  
pannello legno  
Ri-trait  
wooden panel



Pannello legno  
Wooden panel

# Binario a parete Sail

## Sail wall rail

Il binario parete a vista è la risposta all'esigenza progettuale di avere una porta scorrevole il cui binario sia agganciato direttamente alla parete. Questo binario è caratterizzato dalla grafica dei carrelli lasciati visibili e dall'assenza dei tradizionali montanti in alluminio.

Il suo posizionamento a parete incornicia le superfici trasparenti dei pannelli e permette l'integrazione con vani porta finiti, anche di grandi dimensioni, senza necessità di lavori di predisposizione architettonica. Il binario consente un sistema completo di regolazioni, con carrelli dotati di cuscinetti ad alto scorrimento.

The visible wall rails is the answer to the design requirement of having a sliding door whose rail is fixed directly to the wall. In this rails the carriages are visible and there are no traditional aluminum uprights. Its positioning on the wall frames the transparent surfaces of the panels and allows integration with finished door compartments, even large, without the need for any architectural predisposition. The rail provides a complete regulating system and is fitted with easy slide bearings.

### Porta singola / Single door



### Binario Sail / Sail rail

#### BINARIO SUPERIORE / UPPER RAIL

Tipologia binario Rail typology	1 via 1 way	1 via 1 way
Binario Sail a parete Sail wall rail	€/ml 70	€/ml 70



# Sail scorrevole

## Sliding Sail

### 1 PANNELLI SAIL SCORREVOLI / SAIL SLIDING PANELS

Tipo pannello Panel type	Finitura base Base finishing		L 700 - L 900	L 900 - L 1100	L 1100 - L 1300	L 1300 - L 1500
Vetro Glass	Vetro cat. A Glass cat. A	H < 2100	€ 650	€ 720	€ 795	€ 865
		H 2100 - H 2300	€ 675	€ 750	€ 830	€ 895
		H 2300 - H 2500	€ 695	€ 780	€ 860	€ 950
		H 2500 - H 2700	€ 720	€ 810	€ 990	€ 1.030

### 2 FINITURE / FINISHINGS

Tipo pannello Panel type	Finitura Finishing	P. 30				
Vetro Glass	Vetro cat. B Glass cat. B		+ 15%	+ 15%	+ 15%	+ 20%
	Vetro cat. C Glass cat. C		+ 30%	+ 30%	+ 35%	+ 40%

### 3 MANIGLIE / HANDLES

Tipo pannello Panel type	Maniglia Handle	Solo maniglia Only handle
Vetro Glass	Reno 1000mm	+ € 100
	Reno 1600mm	+ € 150
	Ticino 400mm	+ € 100
	Ticino 1600mm	+ € 150
	Arno 600mm	+ € 150
	Arno 1600mm	+ € 250
	Tevere	+ € 150

8 mm

Sail vetro  
Glass SailVetro  
Glass

#### Maniglie pannelli scorrevoli Sliding panels handles

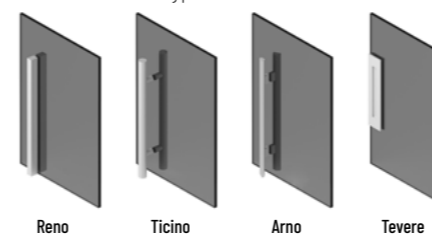

#### CODICI PORTE / DOORS CODES

Tipo pannello Panel type	Pannello porta / Panel door	
	Destra / Right	Sinistra / Left
Vetro Glass	FL-260-D	FL-260-S

#### CODICI MANIGLIE / HANDLES CODES

Maniglia Handle	Solo maniglia Only handle
Reno 1600mm	H1
Reno 1000mm	H
Arno 1600mm	S2
Arno 600mm	S
Ticino 1600mm	T1
Ticino 400mm	T
Tevere	I

# Binario a parete invisibile

## Concealed wall rail

Il "binario scorrevole a parete invisibile" di Albed permette di installare una porta scorrevole a parete senza che il meccanismo di scorrimento sia mai visibile, in qualsiasi posizione. Il pannello si muove scorrendo lungo la parete, senza alcun elemento ulteriore visibile. Il binario è dotato di sistema di rallentamento in apertura e chiusura.

The "sliding concealed rail on the wall" of Albed allows to install a sliding door on the wall avoiding the sliding mechanism to be seen, in any position. The panel moves sliding along the wall, without any further visible element. The rail is equipped with a slow motion system on opening and closing.

### Porta singola / Single door

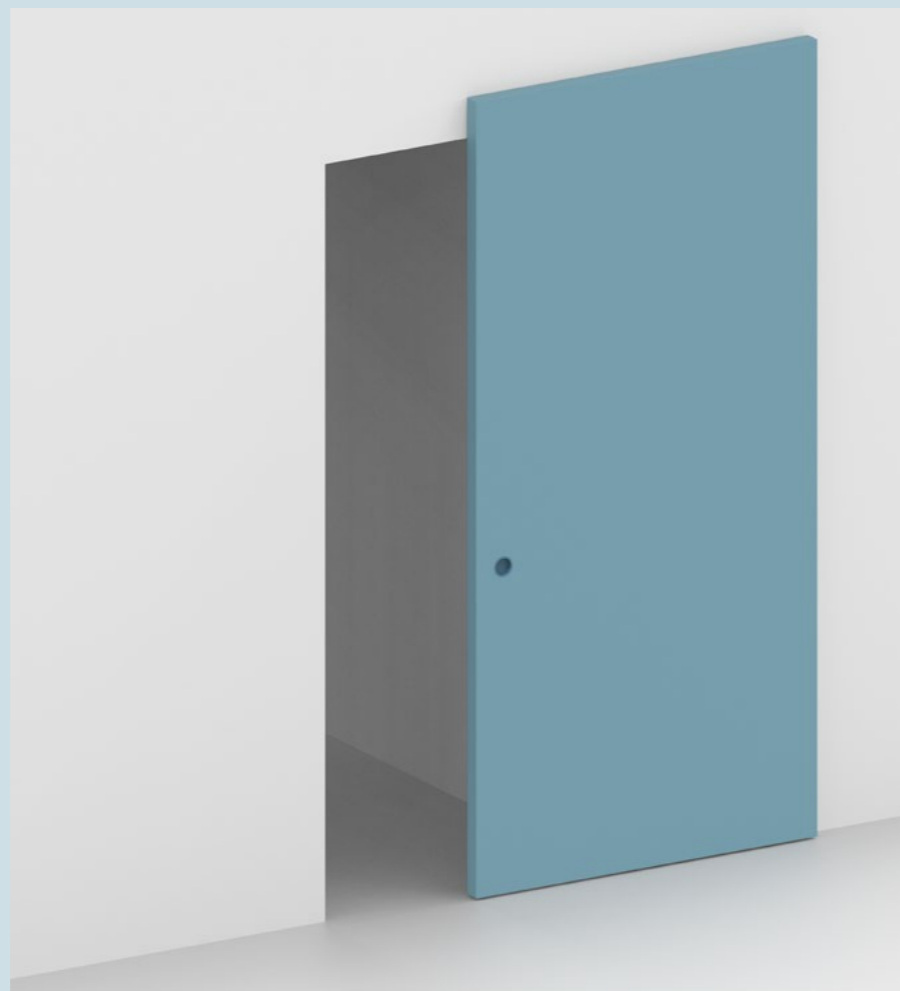

Sezione verticale  
Vertical section

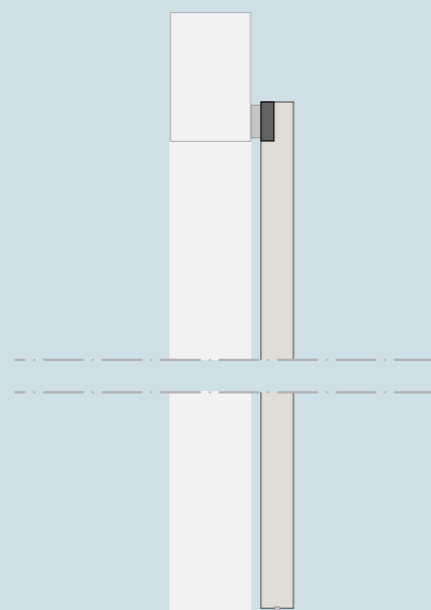

# And scorrevole

## Sliding And

### 1 PANNELLI AND SCORREVOLI CON BINARIO INVIIBILE / AND SLIDING PANELS WITH CONCEALED WALL RAIL

Tipo pannello Panel type	Finitura base Base finishing		L 700 - L 900	L 900 - L 1100	L 1100 - L 1300	
Pannello legno Woodwn panel	Laccato standard Standard lacquered	[1]	H < 2100	€ 1.310	€ 1.444	€ 1.480
			H 2100 - H 2300	€ 1.359	€ 1.480	€ 1.541
			H 2300 - H 2500	€ 1.420	€ 1.535	€ 1.577
			H 2500 - H 2700	€ 1.529	€ 1.656	€ 1.687

### 2 FINITURE / FINISHINGS

Tipo pannello Panel type	Finitura Finishing	P. 30
Pannello legno Woodwn panel	Laccato custom RAL Custom RAL lacquered	+ € 70
	Essenza legno Wood essence	+ € 130

### 4 MANIGLIE / HANDLES

Tipo pannello Panel type	Maniglia Handle	Solo maniglia Only handle
Pannello legno Woodwn panel	Piave	+ € 100
	Loira tonda	+ € 150
	Loira quadrata	+ € 150

### 3 PERSONALIZZAZIONI / PERSONALIZATION

Tipo pannello Panel type	Pantografatura* Grooving*	
Pannello legno Woodwn panel	1 riquadro / 1 square	[2]
	2 riquadri / 2 squares	[3] + € 250
	3 riquadri / 3 squares	[4]

\*Non disponibile con finitura Essenza legno  
\*Non aviable with Wood essence finishing

38 mm



And pannello legno  
Wooden panel And

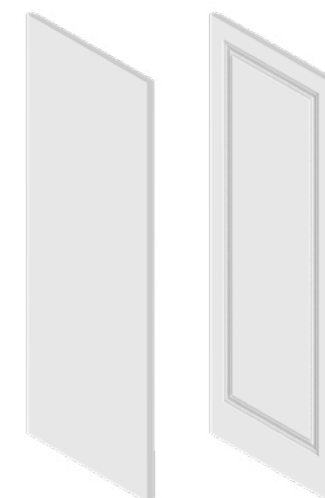

[1]  
Pannello legno  
Woodwn panel

[2]  
Pannello legno panto-  
grafato 1 riquadro  
Grooving wooden  
panel 1 square

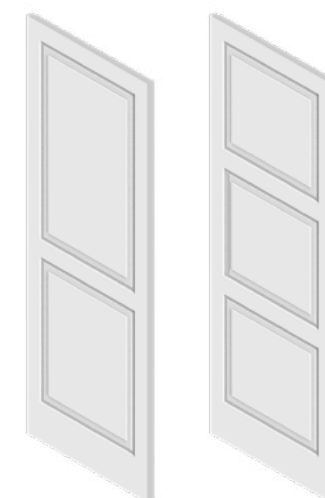

[3]  
Pannello legno panto-  
grafato 2 riquadri  
Grooving wooden  
panel 2 squares

[4]  
Pannello legno panto-  
grafato 3 riquadri  
Grooving wooden  
panel 3 squares

Maniglie pannelli scorrevoli  
Sliding panels handles



Piave

Loira tonda

Loira quadrata

### CODICI PORTE / DOORS CODES

Tipo pannello Panel type	Binario invisibile a parete Wall-mounted invisible rail
[1]	AN-L10
[2]	AN-L12
[3]	AN-L14
[4]	AN-L16

### CODICI MANIGLIE / HANDLES CODES

Maniglia Handle	Solo maniglia Only handle
Piave	Q
Loira tonda*	V1
Loira quadrata*	V4

\*disponibile in finitura cromo satinato o lucido  
\*available in satin or polished chrome finishing

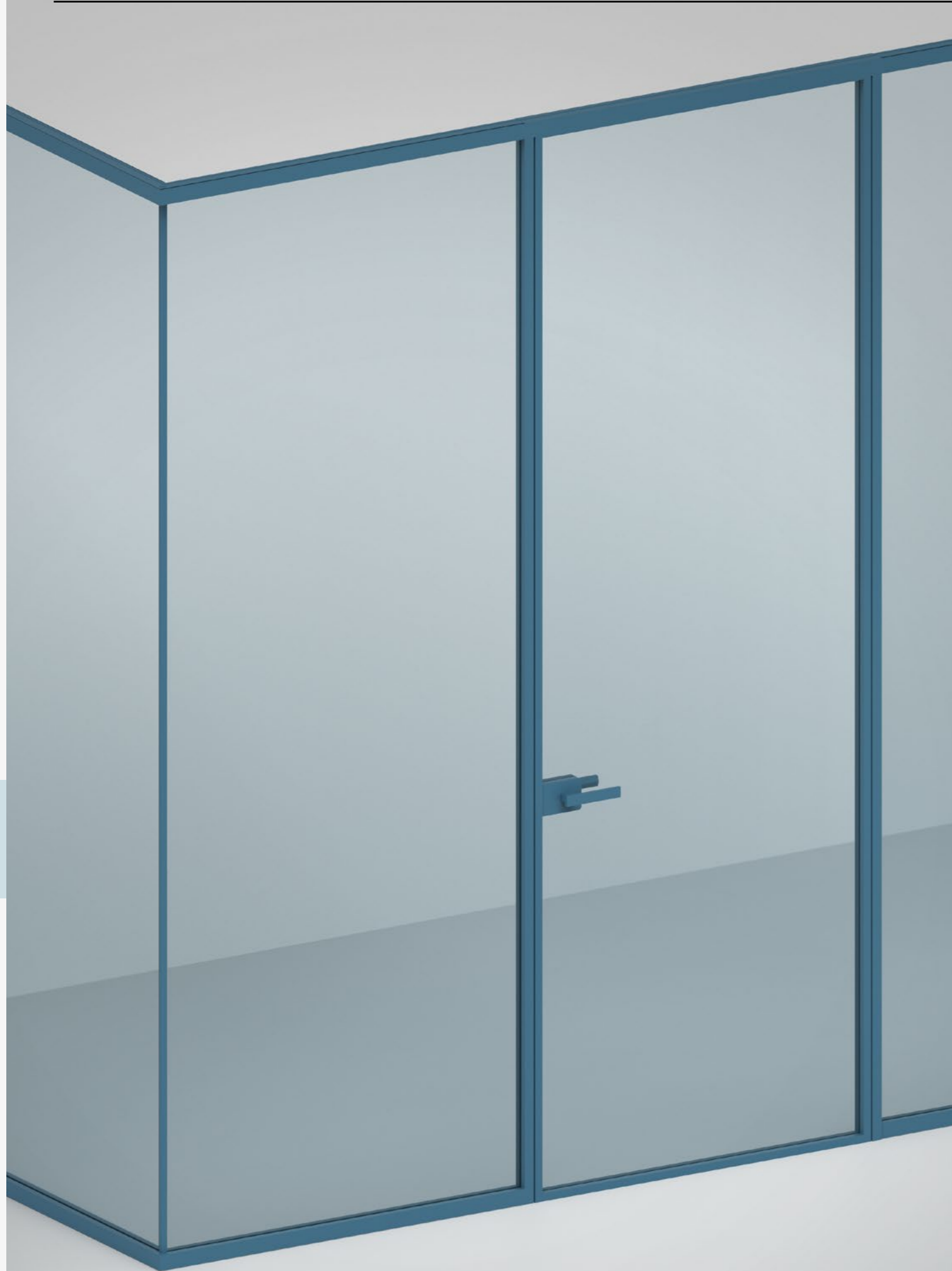

# PARETI DIVISORIE PARTITION WALL

La "parete divisoria" è soluzione ideale per distribuire gli spazi quando c'è la necessità di gestire ampie superfici o di isolare ambienti specifici, sia visivamente che acusticamente, senza generare impatto architettonico.

The "partition wall" is the ideal solution for distributing spaces, when large areas need to be dealt with or specific spaces need to be isolated, both visually and acoustically, without having an architectural impact.

## Sistema prodotto / Product system

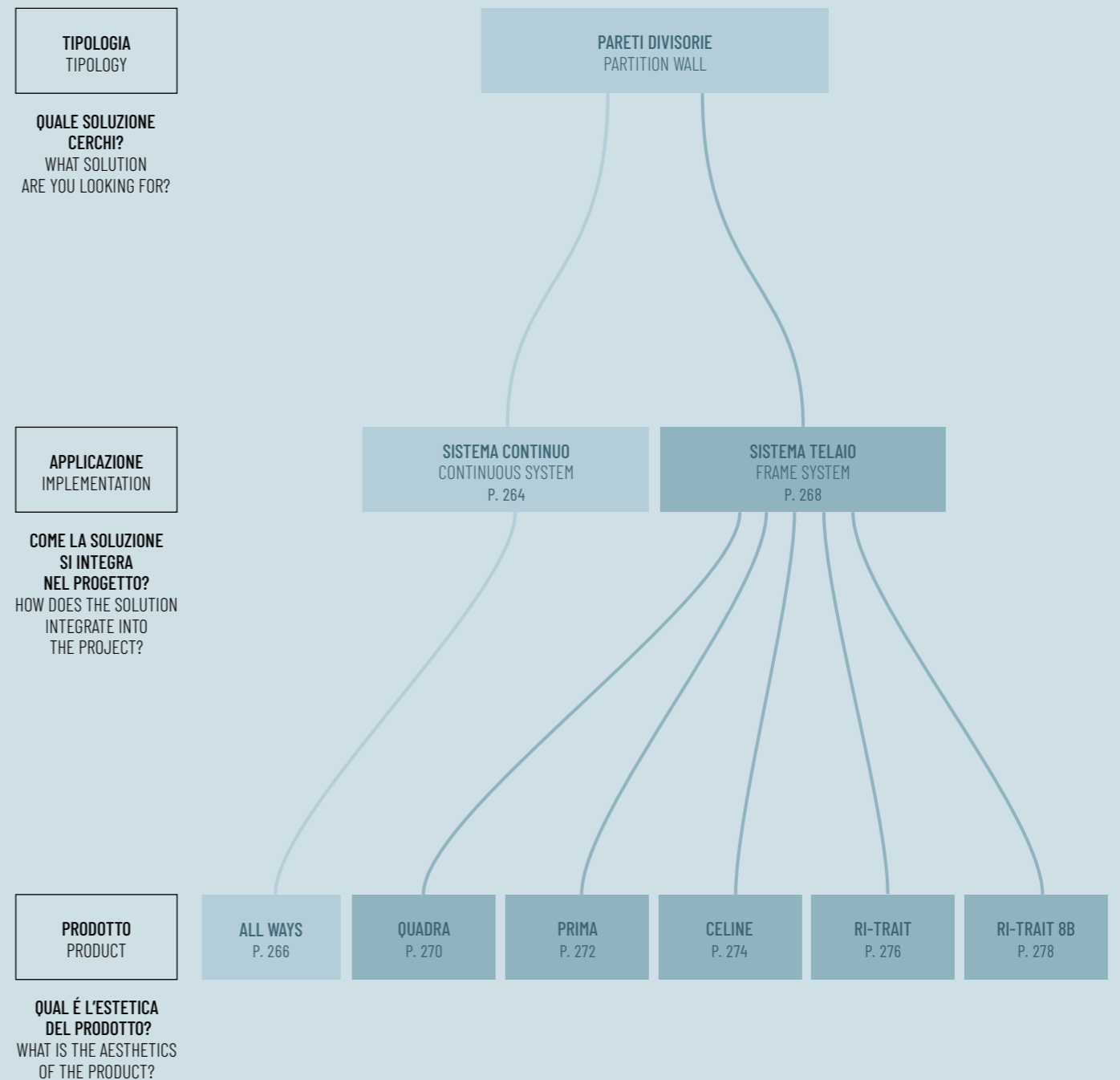

**TIPOLOGIA**  
TIPOLOGY

**QUALE SOLUZIONE CERCHI?**  
WHAT SOLUTION ARE YOU LOOKING FOR?

**APPLICAZIONE**  
IMPLEMENTATION

**COME LA SOLUZIONE SI INTEGRA NEL PROGETTO?**  
HOW DOES THE SOLUTION INTEGRATE INTO THE PROJECT?

**PRODOTTO**  
PRODUCT

**QUAL È L'ESTETICA DEL PRODOTTO?**  
WHAT IS THE AESTHETICS OF THE PRODUCT?

Tavoli / Table  
 Librerie / Bookcase  
 Cabine armadio / Walk-in closet  
 Boiserie / Boiserie  
 Pareti divisorie / Partition wall  
 Pan. scorrevoli o girevoli / Sliding or pivoting panels  
 Porte a scomparsa / Pocket door  
 Porte senza falso telaio / Door w/o basic door frame  
 Porte filomuro / Flush door  
 Porte battenti con cornice / Hinged door and frame  
 Informazioni generali / General informations

Tavoli / Table  
 Librerie / Bookcase  
 Cabine armadio / Walk-in closet  
 Boiserie / Boiserie  
 Pareti divisorie / Partition wall  
 Pan. scorrevoli o girevoli / Sliding or pivoting panels  
 Porte a scomparsa / Pocket door  
 Porte senza falso telaio / Door w/o basic door frame  
 Porte filomuro / Flush door  
 Porte battenti con cornice / Hinged door and frame  
 Informazioni generali / General informations

# Parete divisoria sistema continuo

## Continuous system partition wall

### Sistema parete divisoria All Ways

#### All Ways partition wall System

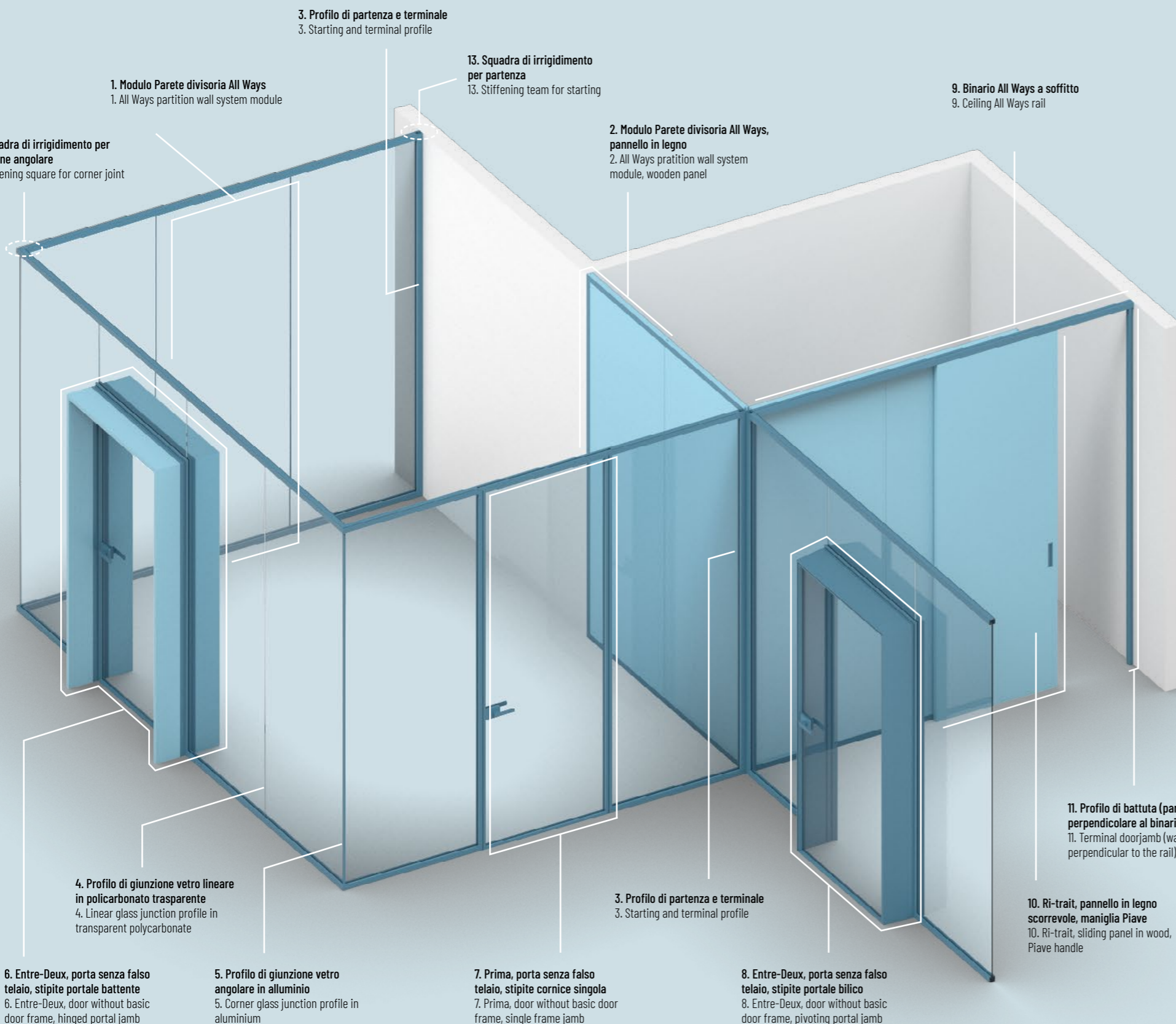

3. Profilo di partenza e terminale  
3. Starting and terminal profile

1. Modulo Parete divisoria All Ways  
1. All Ways partition wall system module

13. Squadra di irrigidimento per partenza  
13. Stiffening team for starting

9. Binario All Ways a soffitto  
9. Ceiling All Ways rail

2. Modulo Parete divisoria All Ways, pannello in legno  
2. All Ways partition wall system module, wooden panel

14. Squadra di irrigidimento per giunzione angolare  
14. Stiffening square for corner joint

Le pareti divisorie a sistema continuo permettono di delineare gli spazi architettonici con superfici trasparenti, anche in grandi dimensioni, senza la presenza di elementi montanti o altre interruzioni visive. Il risultato è una estrema trasparenza e libertà di configurazione di pannelli in vetro, anche con proprietà acustiche. I profili di supporto sono costituiti da elementi lineari fortemente semplificati, che mantengono però una completa regolazione del vetro in fase di installazione.

Continuous system partition walls make it possible to define architectural spaces with transparent surfaces. Even large sized openings can be outfitted without any uprights or other visual interruptions. The result is extreme transparency and freedom of configuration, when using glass panels, including those with acoustic properties. The supports are made of highly simplified linear elements, which maintain complete glass adjustment during installation.

## Componenti / Components

### STRUTTURA / FRAME

1. Parete divisoria All ways  
1. All ways partition wall system module
2. Parete divisoria All ways, pannello in legno  
2. All ways partition wall system module, wooden panel
3. Profilo di partenza e terminale  
3. Starting and terminal profile
4. Profilo di giunzione vetro lineare in policarbonato trasparente  
4. Linear glass junction profile in transparent polycarbonate
5. Profilo di giunzione vetro angolare in alluminio  
5. Corner glass junction profile in aluminium

### PORTE BATTENTI / HINGED DOOR

6. Entre-Deux, porta senza falso telaio, stipite portale battente  
6. Entre-Deux, door without basic door frame, hinged portal jamb
7. Prima, porta senza falso telaio, stipite cornice singola  
7. Prima, door without basic door frame, single frame jamb

### PORTE A BILICO / PIVOTING DOOR

8. Entre-Deux, porta senza falso telaio, stipite portale bilico  
8. Entre-Deux, door without basic door frame, pivoting portal jamb

### PANNELLI SCORREVOLI / SLIDING DOORS

9. Binario All Ways a soffitto  
9. Ceiling All Ways rail
10. Ri-trait, pannello in legno scorrevole, maniglia Piave  
10. Ri-trait, sliding panel in wood, Piave handle
11. Profilo di battuta (parete perpendicolare al binario)  
11. Terminal doorjamb (wall perpendicular to the rail)

11. Profilo di battuta (parete perpendicolare al binario)  
11. Terminal doorjamb (wall perpendicular to the rail)

10. Ri-trait, pannello in legno scorrevole, maniglia Piave  
10. Ri-trait, sliding panel in wood, Piave handle

8. Entre-Deux, porta senza falso telaio, stipite portale bilico  
8. Entre-Deux, door without basic door frame, pivoting portal jamb

7. Prima, porta senza falso telaio, stipite cornice singola  
7. Prima, door without basic door frame, single frame jamb

5. Profilo di giunzione vetro angolare in alluminio  
5. Corner glass junction profile in aluminium

6. Entre-Deux, porta senza falso telaio, stipite portale battente  
6. Entre-Deux, door without basic door frame, hinged portal jamb

Informazioni generali / General informations  
 Porte battenti con cornice / Hinged door and frame  
 Porte effetto filomuro / Flush-effect door  
 Porte filomuro / Flush door  
 Porte senza falso telaio / Door w/o basic door frame  
 Porte a scomparsa / Pocket door  
 Porte scorrevoli o girevoli / Sliding or pivoting panels  
 Pareti divisorie / Partition wall  
 Boiseries / Boiserie  
 Cabine armadio / Walk-in closet  
 Librerie / Bookcase  
 Tavoli / Table

Informazioni generali / General informations  
 Porte battenti con cornice / Hinged door and frame  
 Porte effetto filomuro / Flush-effect door  
 Porte filomuro / Flush door  
 Porte senza falso telaio / Door w/o basic door frame  
 Porte a scomparsa / Pocket door  
 Porte scorrevoli o girevoli / Sliding or pivoting panels  
 Pareti divisorie / Partition wall  
 Boiseries / Boiserie  
 Cabine armadio / Walk-in closet  
 Librerie / Bookcase  
 Tavoli / Table

# Sistema parete divisoria All Ways

## All Ways partition wall system

### 1 PARETE DIVISORIA ALL WAYS / PARETE DIVISORIA ALL WAYS

Tipo parete Wall type	Finitura base Base finishing		Prezzo Price	Codici Codes
Vetro 10mm* 10mm glass*	Trasparente	[1]	€/mq 250	AWDC001
Pannello legno Wooden panel	Laccato standard Standard lacquered	[2]	€/mq 750	AWDC002

\*Per vetro 12mm rivolgersi all'ufficio commerciale

\*For 12mm glass, please contact the sales office

Altezza standard parete: H 2300 - H 3200

Standard wall height: H 2300 - H 3200

La dimensione delle lastre in vetro e dei pannelli in legno è calcolata per avere il minimo numero di divisioni, L max 1200mm.

Tra le lastre di vetro è presente un profilo di collegamento in alluminio, possibilità di sostituirlo con un profilo in policarbonato trasparente con un sovrapprezzo + € 50 per ogni barra da 3000mm

The glasses dimensions are calculated in order to have the minimum quantity of division, L max 1200mm.

An aluminum connection profile between the glass panes is included. On request, a transparent polycarbonate profile is available, the surcharge is + € 50 for every bar of 3000mm

### 2 FINITURE / FINISHINGS

Tipo parete Wall type	Finitura Finishing	P. 30
Vetro 10mm 10mm glass	Vetro Cat. A / Glass Cat. A	+ 60%
	Vetro Cat. B / Glass Cat. B	+ 100%
	Vetro Cat. C / Glass Cat. C	+ 120%
	Vetro Cat. D / Glass Cat. D	+ 150%
	Vetro Cat. E / Glass Cat. E	+ 300%
Pannello legno Wooden panel	Laccato custom RAL Custom RAL lacquered	+ 12%
	Essenza legno Wood essence	+ 12%

### 3 ALTEZZE CUSTOM / CUSTOM HEIGHT

Tipo pannello Panel type	Altezza parete divisoria Partition wall height	
Vetro 10mm 10mm glass	H < 2300	+ 10%
Pannello legno Wooden panel	H < 2300	+ 10%

### 4 VETRO ACUSTICO / ACOUSTIC GLASS

Tipo pannello Panel type	Miglioramento acustico Acoustic improvement	
Vetro 10mm 10mm glass	Pellicola in PVB acustico* Acoustic PVB film*	€/mq 97

\*Non compatibile con finitura Trasparente e Satinato. Disponibile per tutti i vetri stratificati, la pellicola in PVB viene posizionata tra le due lastre migliorando la capacità di isolamento acustico.

\*Not compatible with Trasparente and Satinato finishings. Available for all laminated glass, the PVB film is placed between the two glasses increasing the the sound-proof capacity.

### 5 PORTE / DOORS

Tipologia Typology	Stipite o binario Jamb or rail	Pannello porta Door panel	Pagina listino Page price book
Porte senza falso telaio Door without basic door frame	Stipite telaio singolo Single frame jamb	QUADRA	P. 156
		PRIMA	P. 158
		CELINE	P. 160
		RI-TRAIT	P. 162
		RI-TRAIT 8B	P. 164
Porte con falso telaio Door with basic door frame	Stipite portale battente Hinged portal jamb	ENTRE-DEUX	P. 178
		ENTRE-DEUX	
Pannelli scorrevoli Sliding panels	Binario All Ways All Ways rail	QUADRA	P. 246
		PRIMA	P. 248
		CELINE	P. 249
		RI-TRAIT	P. 250
		RI-TRAIT 8B	P. 251
		SAIL	P. 259

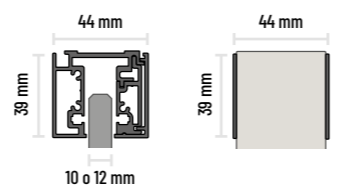

Profilo orizzontale sviluppo parete vetro  
Horizontal profile glass wall development

Profilo orizzontale sviluppo parete legno  
Horizontal profile wooden wall development

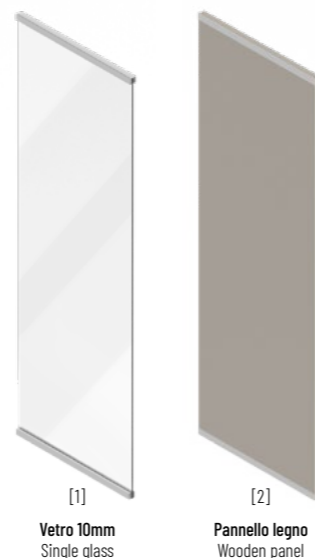

[1]  
Vetro 10mm  
Single glass

[2]  
Pannello legno  
Wooden panel

# Struttura parete divisoria All Ways

## All Ways partition wall structure

### Profili verticali / Vertical profiles

#### PROFILI VERTICALI IN ALLUMINIO / VERTICAL PROFILES IN ALUMINIUM

Elemento Element	H < 2300	H 2300 - H 2700	H 2700 - H 3200	Codici Codes
Profilo di partenza e terminale Starting and terminal profile	€ 180	€ 210	€ 240	AWDC003
Profilo terminale cieco Terminal profile	€ 140	€ 160	€ 180	AWDC004
Profilo di giunzione vetro lineare in alluminio Linear glass junction profile in aluminium	***	***	***	AWDC005
Profilo di giunzione vetro angolare in alluminio Corner glass junction profile in aluminium	€ 70	€ 70	€ 70	AWDC007
Nodo di collegamento per incroci a 90° Connecting node for 90° crossings	€ 150	€ 170	€ 180	AWDC011

\*\*\*prezzo incluso dello sviluppo parete divisoria  
\*\*\*price included in the partition wall development

#### PROFILI VERTICALI IN POLICARBONATO TRASPARENTE / VERTICAL PROFILES IN TRANSPARENT POLYCARBONATE

Elemento Element	H 3000	Codici Codes
Profilo di giunzione vetro lineare in policarbonato trasparente Linear glass junction profile in transparent polycarbonate	€ 50	AWDC006
Profilo di giunzione vetro angolare in policarbonato trasparente Corner glass junction profile in transparent polycarbonate	€ 50	AWDC010

### Binari per porte scorrevoli / Sliding door rail

#### BINARIO E ACCESSORI BINARIO ALL WAYS / RAIL AND RAIL ACCESSORIES ALL WAY

Elemento Element	Prezzo Price	Codici Codes
Binario All Ways a soffitto Ceiling All Ways rail	€/ml 100	AWDC016
Coppia di tappi di chiusura per binario All Ways a soffitto Pair of plugs to cover the sides of the ceiling All Ways rail	€ 20	AWDC017
Profilo di battuta (parete perpendicolare al binario) Terminal doorjamb (wall perpendicular to the rail)	€ 190	AWDC018
Profilo di battuta (parete parallela al binario) Terminal doorjamb (wall parallel to the rail)	€ 190	AWDC019

### Elementi per struttura autoportante / Elements for self-supporting structure

#### ACCESSORI PER STRUTTURA AUTOPORTANTE / SELF-SUPPORTING STRUCTURE ACCESSORIES

Elemento Element	Prezzo Price	Codici Codes
Trave orizzontale di irrigidimento (L max 5800) Horizontal stiffening beam (L max 5800)	€/ml 120	AWDC012
Giunzione lineare per travi orizzontali di irrigidimento Linear joint for horizontal stiffening beams	€ 80	AWDC013

# Parete divisoria sistema telaio

## Frame system partition wall

### Parete divisoria con pannelli su binario Evo a soffitto

#### Partition wall with panels on ceiling Evo rail

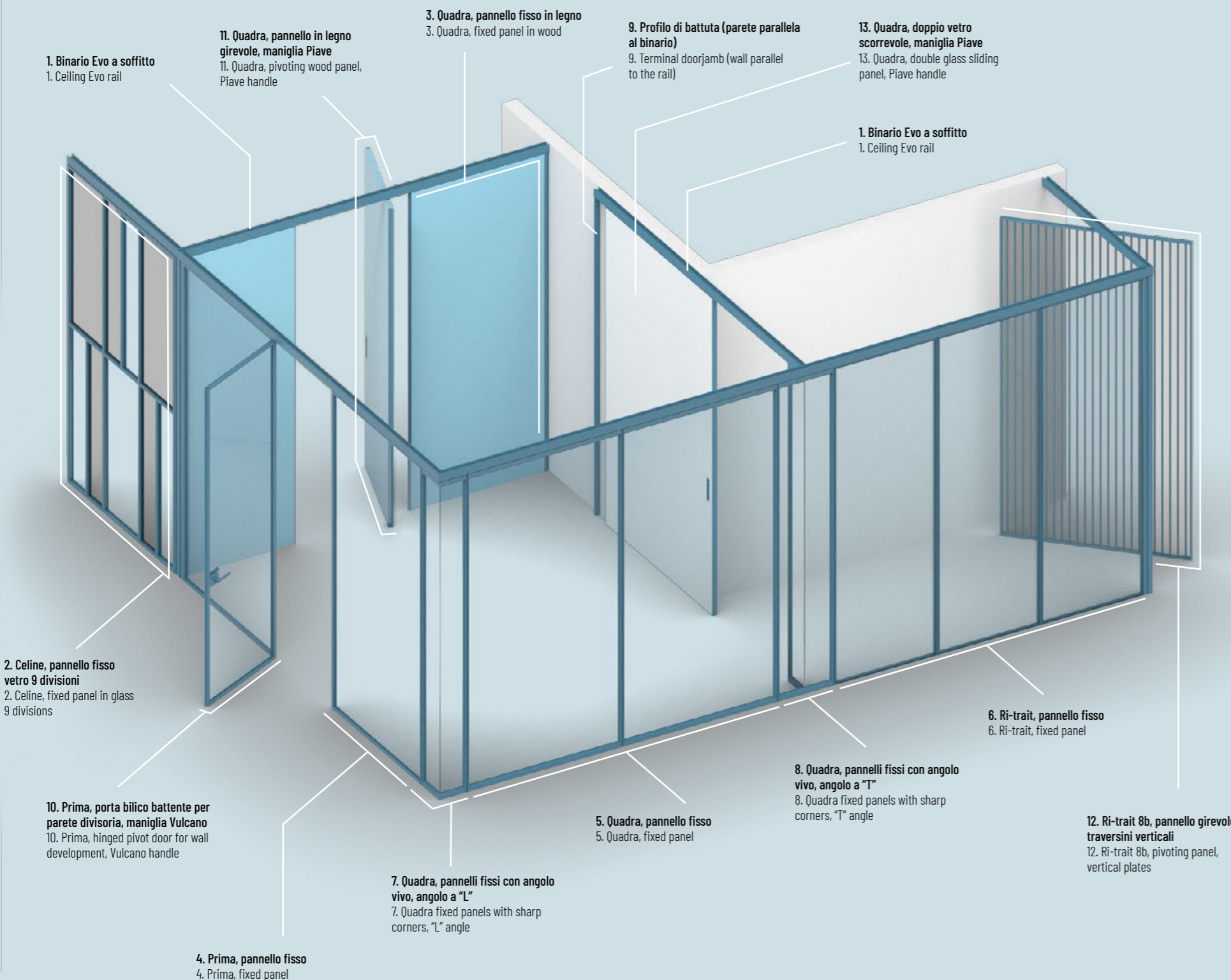

Le pareti divisorie a sistema telaio si compongono di singoli elementi incorniciati. Ogni vetro è delineato da un sottile profilo in alluminio che lo valorizza. Questo sistema divisorio si adatta particolarmente ad approcci architettonici che vogliono valorizzare la divisione e la connessione degli spazi, giocando con filtri, trasparenze, ripetizioni di elementi metallici o composizioni di vetri, anche in finiture diverse.

The frame system partition walls are made of individual framed elements. Each glass panel is attractively outlined by a thin aluminium profile. This partitioning system is particularly suitable for architectural approaches designed to enhance the dividing up and connection of spaces, also through playing with filters, transparency, and repetition of metal elements or glass compositions, also with differing finishes.

## Componenti / Components

### STRUTTURA / FRAME

- 1. Binario Evo a soffitto**  
1. Ceiling Evo rail
- 2. Celine, pannello fisso vetro 9 divisioni**  
2. Celine, fixed panel in glass 9 divisions
- 3. Quadra, pannello fisso in legno**  
3. Quadra, fixed panel in wood
- 4. Prima, pannello fisso**  
4. Prima, fixed panel
- 5. Quadra, pannello fisso**  
5. Quadra, fixed panel
- 6. Ri-trait, pannello fisso**  
6. Ri-trait, fixed panel
- 7. Quadra, pannelli fissi con angolo vivo, angolo a "L"**  
7. Quadra fixed panels with sharp corners, "L" angle
- 8. Quadra, pannelli fissi con angolo vivo, angolo a "T"**  
8. Quadra fixed panels with sharp corners, "T" angle
- 9. Profilo di battuta (parete parallela al binario)**  
9. Terminal doorjamb (wall parallel to the rail)

### PORTE BATTENTI / HINGED DOORS

- 10. Prima, porta bilico battente per parete divisoria, maniglia Vulcano**  
10. Prima, hinged pivot door for wall development, Vulcano handle

### PANNELLI A BILICO / PIVOTING DOORS

- 11. Quadra, pannello in legno girevole, maniglia Piave**  
11. Quadra, pivoting wood panel, Piave handle
- 12. Ri-trait 8b, pannello girevole, traversini verticali**  
12. Ri-trait 8b, pivoting panel, vertical plates

### PANNELI SCORREVOLI / SLIDING DOORS

- 13. Quadra, pannello doppio vetro scorrevole, maniglia Piave**  
13. Quadra, double glass sliding panel, Piave handle

Informazioni generali / General informations  
 Porte battenti con cornice / Hinged door and frame  
 Porte effetto filomuro / Flush-effect door  
 Porte filomuro / Flush door  
 Porte senza falso telaio / Door w/o basic door frame  
 Porte a scomparsa / Pocket door  
 Pan. scorrevoli o girevoli / Sliding or pivoting panels  
 Pareti divisorie / Partition wall  
 Boiseries / Boiserie  
 Cabine armadio / Walk-in closet  
 Librerie / Bookcase  
 Tavoli / Table

Informazioni generali / General informations  
 Porte battenti con cornice / Hinged door and frame  
 Porte effetto filomuro / Flush-effect door  
 Porte filomuro / Flush door  
 Porte senza falso telaio / Door w/o basic door frame  
 Porte a scomparsa / Pocket door  
 Pan. scorrevoli o girevoli / Sliding or pivoting panels  
 Pareti divisorie / Partition wall  
 Boiseries / Boiserie  
 Cabine armadio / Walk-in closet  
 Librerie / Bookcase  
 Tavoli / Table





# Sistema parete divisoria Prima

## Prima partition wall system

### 1 PANNELLI PRIMA FISSI / PRIMA FIXED PANELS

Tipo pannello Panel type	Finitura base Base finishing		L 500 - L 700	L 700 - L 900	L 900 - L 1100	L 1100 - L 1300	L 1300 - L 1500
Vetro Glass	Vetro Cat. A Glass Cat. A	H < 2100	€ 995	€ 1.068	€ 1.245	€ 1.330	€ 1.390
		H 2100 - H 2300	€ 1.036	€ 1.116	€ 1.300	€ 1.390	€ 1.461
	Finitura alluminio anodizzato o RAL 9003 Anodized aluminum finishing or RAL 9003	H 2300 - H 2500	€ 1.076	€ 1.164	€ 1.340	€ 1.436	€ 1.544
		H 2500 - H 2700	€ 1.117	€ 1.212	€ 1.390	€ 1.494	€ 1.582
		H 2700 - H 3000	€ 1.179	€ 1.234	€ 1.420	€ 1.531	€ 1.635
	H 3000 - H 3200	€ 1.220	€ 1.282	€ 1.490	€ 1.597	€ 1.695	

### 2 FINITURE / FINISHINGS

Tipo pannello Panel type	Finitura Finishing	P. 30					
Vetro Glass	Vetro Cat. B / Glass Cat. B		+ 13%	+ 15%	+ 16%	+ 17%	+ 19%
	Vetro Cat. C / Glass Cat. C		+ 19%	+ 24%	+ 27%	+ 27%	+ 30%
	Vetro Cat. D / Glass Cat. D		+ 40%	+ 50%	+ 58%	+ 58%	+ 65%
	Vetro Cat. E / Glass Cat. E		+ 65%	+ 95%	+ 95%	+ 95%	+ 105%

### 3 PERSONALIZZAZIONI / PERSONALIZATION

Tipo pannello Panel type	Divisioni vetro Glass divisions	
Vetro Glass	2 divisioni / 2 divisions [2]	+ € 60
	3 divisioni / 3 divisions [3]	+ € 120

### 4 CONVERSIONE IN PANNELLO PORTA CONVERSION TO DOOR PANEL

Tipo pannello Panel type	Tipo di apertura Opening type	
Vetro Glass	Porta bilico battente* Hinged pivot door*	+ € 200
	Porta bilico bidirezionale* Bi-directional pivot door*	+ € 200
	Pannello scorrevole Sliding panel	+ € 100
	Pannello girevole Pivoting panel	+ € 100

\* porte disponibili fino L1000. Serratura compresa nel prezzo maniglia  
\* doors available up to L 1000. Lock included in the handle price

### 5 MANIGLIE / HANDLES

Tipo pannello Panel type	Tipologia di apertura Opening type	Maniglia Handle	Solo maniglia Only handle	Chiave patent Patent key	Nottolino Latch free/busy	Chiave Yale Yale key
Vetro Glass	Porta bilico battente o Porta bilico bidirezionale Hinged pivot door or Bi-directional pivot door	Etna	+ € 250	-	+ € 290	+ € 350
		Vesuvio	+ € 270	-	+ € 300	+ € 370
		Vulcano	+ € 250	-	+ € 290	+ € 350
Vetro Glass	Pannello scorrevole Sliding panel	Loira	+ € 150	+ € 250 **	+ € 250 **	-
		Adige 200mm	+ € 100	-	-	-
		Adige 100mm	+ € 100	-	-	-
		Adige 300mm	+ € 200	-	-	-

\*per pannelli pivotanti è possibile ordinare 0, 1 o 2 maniglie. In caso di 1 maniglia specificare se posizionarla a destra o a sinistra  
\*for pivoting panels it is possible to order 0, 1 or 2 handles. In case of 1 handle, specify to position it on the right or on the left

\*\*opzione disponibile solo per pannello scorrevole, necessita di un profilo di battuta con incontro  
\*\*option only available for sliding panel, requires terminal doorjamb with striker

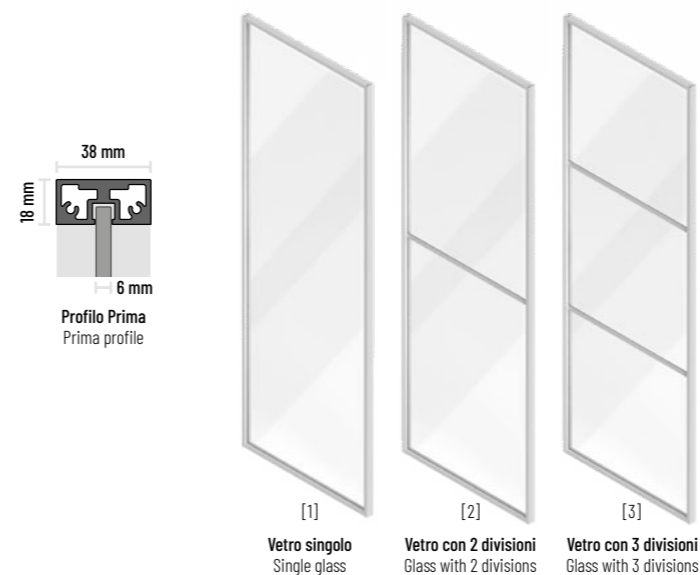

### CODICI PORTE / DOORS CODES

Tipo pannello Panel type	Pannello fisso per parete divisoria Fixed panel for wall development	Porta bilico battente per parete divisoria Hinged pivot door for wall development	Porta bilico bidirezionale per parete divisoria Bi-directional pivot door for wall development	Pannello scorrevole Sliding panel	Pannello girevole Pivoting panel
[1]	PR-F1	PR-P1BT	PR-P1B	PR-A1	PR-A1P
[2]	PR-F2	PR-P2BT	PR-P2B	PR-A2	PR-A2P
[3]	PR-F3	PR-P3BT	PR-P3B	PR-A3	PR-A3P

### Maniglie porta bilico battente o bidirezionale Hinged pivot door or bi-directional pivot door handles

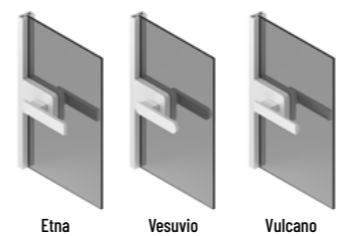

Etna

Vesuvio

Vulcano

### Maniglie pannelli scorrevoli Sliding panels handles

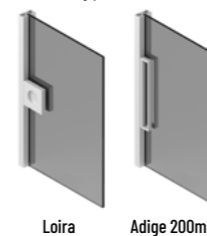

Loira

Adige 200mm

### Maniglie pannelli girevoli Pivoting panels handles

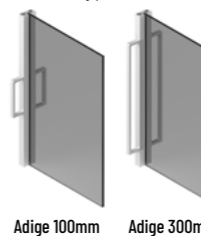

Adige 100mm

Adige 300mm

### CODICI MANIGLIE / HANDLES CODES

Maniglia Handle	Solo maniglia Only handle	Chiave patent Patent key	Nottolino Latch free/busy	Chiave Yale Yale key
Etna	PR-PS10	-	PR-PS20	PR-PS30
Vesuvio	PR-PS1000	-	PR-PS2000	PR-PS3000
Vulcano	PR-PS100	-	PR-PS200	PR-PS300
Loira	C1	C2	C3	-
Adige 100mm	RX	-	-	-
Adige 200mm	M	-	-	-
Adige 300mm	R2X	-	-	-

# Sistema parete divisoria Celine

## Celine partition wall system

### 1 PANNELLI CELINE FISSI / CELINE FIXED PANELS

Tipo pannello Panel type	Finitura base Base finishing	L 500 - L 700	L 700 - L 900	L 900 - L 1100	L 1100 - L 1300	L 1300 - L 1500		
Vetro Glass	Vetro Cat. A Glass Cat. A	[1][2]	H < 2100	€ 1.522	€ 1.613	€ 1.703	€ 1.794	€ 1.884
			H 2100 - H 2300	€ 1.557	€ 1.655	€ 1.753	€ 1.851	€ 1.949
			H 2300 - H 2500	€ 1.593	€ 1.697	€ 1.803	€ 1.907	€ 2.013
			H 2500 - H 2700	€ 1.627	€ 1.739	€ 1.851	€ 1.965	€ 2.077
			H 2700 - H 3000	€ 1.680	€ 1.803	€ 1.926	€ 2.049	€ 2.140
			H 3000 - H 3200	€ 1.745	€ 1.845	€ 1.976	€ 2.106	€ 2.236
		[3][4]	H < 2100	€ 1.522	€ 1.613	€ 1.703	-	-
			H 2100 - H 2300	€ 1.557	€ 1.655	€ 1.753	-	-
			H 2300 - H 2500	€ 1.593	€ 1.697	€ 1.803	-	-
			H 2500 - H 2700	€ 1.627	€ 1.739	€ 1.851	-	-
			H 2700 - H 3000	€ 1.680	€ 1.803	€ 1.926	-	-
			H 3000 - H 3200	€ 1.745	€ 1.845	€ 1.976	-	-
	Finitura alluminio anodizzato o RAL 9003 Anodized aluminum finishing or RAL 9003	[5][6]	H < 2100	-	-	-	€ 1.794	€ 1.884
			H 2100 - H 2300	-	-	-	€ 1.851	€ 1.949
			H 2300 - H 2500	-	-	-	€ 1.907	€ 2.013
			H 2500 - H 2700	-	-	-	€ 1.965	€ 2.077
			H 2700 - H 3000	-	-	-	€ 2.049	€ 2.140
			H 3000 - H 3200	-	-	-	€ 2.106	€ 2.236
		[7][8]	H < 2100	-	-	-	-	€ 1.884
			H 2100 - H 2300	-	-	-	-	€ 1.949
			H 2300 - H 2500	-	-	-	-	€ 2.013
			H 2500 - H 2700	-	-	-	-	€ 2.077
			H 2700 - H 3000	-	-	-	-	€ 2.140
			H 3000 - H 3200	-	-	-	-	€ 2.236

### 2 FINITURE / FINISHINGS

Tipo pannello Panel type	Finitura Finishing	P. 30	↓	↓	↓	↓	↓
Vetro Glass	Vetro Cat. B / Glass Cat. B		+ 7%	+ 8%	+ 8%	+ 8%	+ 9%
	Vetro Cat. C / Glass Cat. C		+ 19%	+ 24%	+ 27%	+ 27%	+ 30%
	Vetro Cat. D / Glass Cat. D		+ 20%	+ 30%	+ 33%	+ 35%	+ 45%
	Vetro Cat. E / Glass Cat. E		+ 35%	+ 65%	+ 65%	+ 65%	+ 70%

Specificare 2 finiture diverse per le divisioni del vetro.  
Specify 2 different finishes for the glass divisions.

In caso di 3 o più finiture diverse sovrapprezzo + 5%  
In case of 3 or more different finishes, surcharge of + 5%

Per finiture di categorie diverse il prezzo viene  
calcolato sulla categoria più alta.  
For finishes of different categories the price is  
calculated on the highest category.

### 3 CONVERSIONE IN PANNELLO PORTA CONVERSION TO DOOR PANEL

Tipo pannello Panel type	Tipo di apertura Opening type	
Vetro Glass	Porta bilico battente* Hinged pivot door*	+ € 200
	Porta bilico bidirezionale* Bi-directional pivot door*	+ € 200
	Pannello scorrevole Sliding panel	+ € 100
	Pannello girevole Pivoting panel	+ € 100

\* porte disponibili fino L1000. Serratura compresa nel prezzo maniglia  
\* doors available up to L 1000. Lock included in the handle price

### 4 MANIGLIE / HANDLES

Tipo pannello Panel type	Tipo di apertura Opening type	Maniglia Handle	Solo maniglia Only handle	Chiave patent Patent key	Nottolino Latch free/busy	Chiave Yale Yale key
Vetro Glass	Porta bilico battente o Porta bilico bidirezionale Hinged pivot door or Bi-directional pivot door	Etna	+ € 250	-	+ € 290	+ € 350
		Vesuvio	+ € 270	-	+ € 300	+ € 370
		Vulcano	+ € 250	-	+ € 290	+ € 350
	Pannello scorrevole Sliding panel	Loira	+ € 150	+ € 250**	+ € 250**	-
		Adige 200mm	+ € 100	-	-	-
		Pannello girevole* Pivoting panel*	Adige 100mm	+ € 100	-	-
Adige 300mm	+ € 200		-	-	-	

\*per pannelli pivotanti è possibile ordinare 0, 1 o 2 maniglie. In caso di 1 maniglia specificare se posizionarla a destra o a sinistra  
\*for pivoting panels it is possible to order 0, 1 or 2 handles. In case of 1 handle, specify to position it on the right or on the left

\*\*opzione disponibile solo per pannello scorrevole, necessita di un profilo di battuta con incontro  
\*\*option only available for sliding panel, requires terminal doorjamb with striker

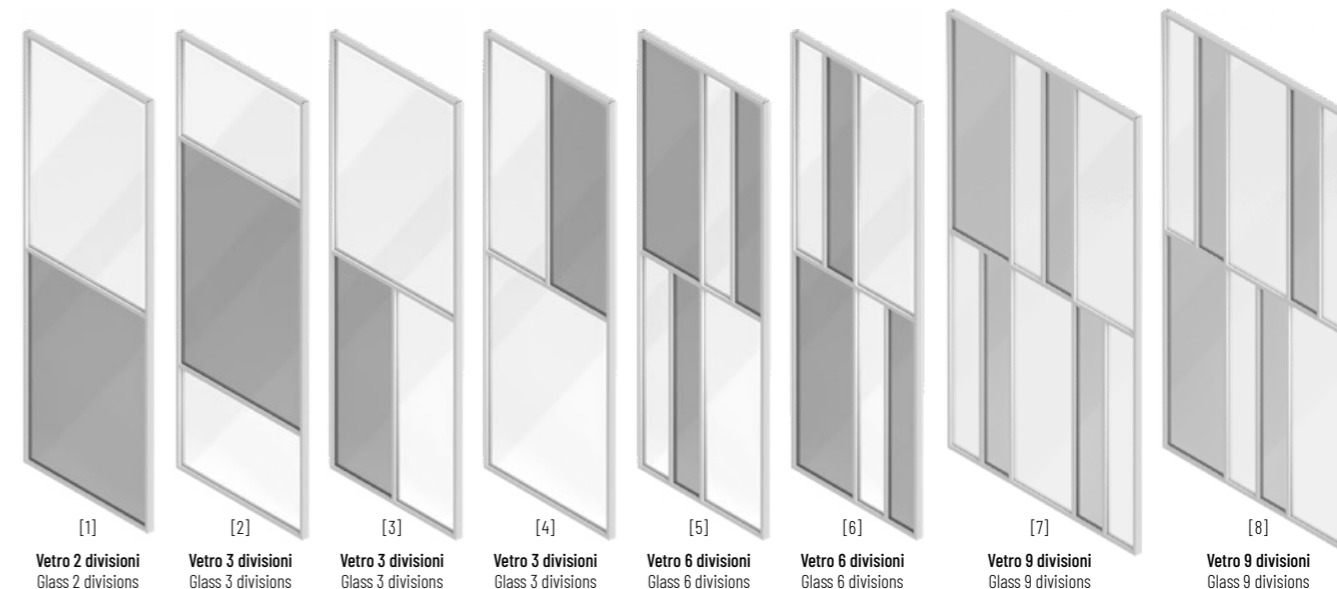

### CODICI PORTE / DOORS CODES

Tipo pannello Panel type	Pannello fisso per parete divisoria Fixed panel for wall development	Porta bilico battente per parete divisoria Hinged pivot door for wall development	Porta bilico bidirezionale per parete divisoria Bi-directional pivot door for wall development	Pannello scorrevole Sliding panel	Pannello girevole Pivoting panel
[1]	CL-F1	CL-P1BT	CL-P1B	CL-A1	CL-A1P
[2]	CL-F2	CL-P2BT	CL-P2B	CL-A2	CL-A2P
[3]	CL-F3	CL-P3BT	CL-P3B	CL-A3	CL-A3P
[4]	CL-F4	CL-P4BT	CL-P4B	CL-A4	CL-A4P
[5]	CL-F5	CL-P5BT	CL-P5B	CL-A5	CL-A5P
[6]	CL-F6	CL-P6BT	CL-P6B	CL-A6	CL-A6P
[7]	CL-F7	-	-	-	-
[8]	CL-F8	-	-	-	-

Maniglie porta bilico battente o bidirezionale  
Hinged pivot door or bi-directional pivot door handles

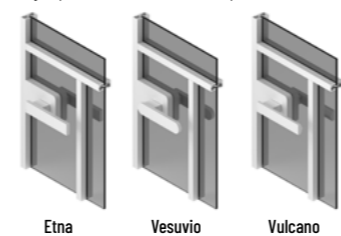

Maniglie pannelli scorrevoli  
Sliding panels handles

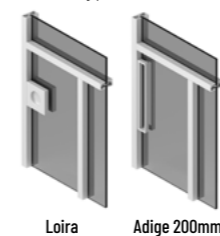

Maniglie pannelli girevoli  
Pivoting panels handles

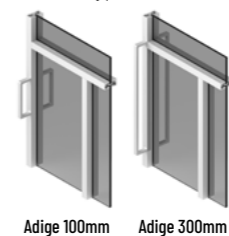

### CODICI MANIGLIE / HANDLES CODES

Maniglia Handle	Solo maniglia Only handle	Chiave Patent Patent key	Nottolino Latch free/busy	Chiave Yale Yale key
Etna	PR-PS10	-	PR-PS20	PR-PS30
Vesuvio	PR-PS1000	-	PR-PS2000	PR-PS3000
Vulcano	PR-PS100	-	PR-PS200	PR-PS300
Loira	C1	C2	C3	-
Adige 100mm	RX	-	-	-
Adige 200mm	M	-	-	-
Adige 300mm	R2X	-	-	-

# Sistema parete divisoria Ri-trait

## Ri-trait partition wall system

### 1 PANNELLI RI-TRAIT FISSI / RI-TRAIT FIXED PANELS

Tipo pannello Panel type	Finitura base Base finishing		L 500 - L 700	L 700 - L 900	L 900 - L 1100	L 1100 - L 1300	L 1300 - L 1500
Vetro Glass	Vetro Cat. A Glass Cat. A	H < 2100	€ 1.073	€ 1.190	€ 1.307	€ 1.425	€ 1.542
		H 2100 - H 2300	€ 1.120	€ 1.247	€ 1.374	€ 1.501	€ 1.626
		H 2300 - H 2500	€ 1.167	€ 1.303	€ 1.440	€ 1.577	€ 1.710
	Finitura alluminio anodizzato / Anodized aluminum finishing	H 2500 - H 2700	€ 1.213	€ 1.360	€ 1.506	€ 1.653	€ 1.794
		H 2700 - H 3000	€ 1.283	€ 1.445	€ 1.606	€ 1.767	€ 1.910
	H 3000 - H 3200	€ 1.290	€ 1.590	€ 1.690	€ 1.843	€ 2.005	

### 2 FINITURE / FINISHINGS

Tipo pannello Panel type	Finitura Finishing	P. 30					
Vetro Glass	Vetro Cat. B / Glass Cat. B		+ 10%	+ 10%	+ 10%	+ 10%	+ 10%
	Vetro Cat. C / Glass Cat. C		+ 20%	+ 20%	+ 28%	+ 28%	+ 28%
	Vetro Cat. D / Glass Cat. D		+ 30%	+ 30%	+ 40%	+ 40%	+ 45%
	Vetro Cat. E / Glass Cat. E		+ 65%	+ 95%	+ 95%	+ 95%	+ 105%

### 3 CONVERSIONE IN PANNELLO PORTA CONVERSION TO DOOR PANEL

Tipo pannello Panel type	Tipo di apertura Opening type	
Vetro Glass	Porta bilico battente* Hinged pivot door*	+ € 200
	Porta bilico bidirezionale* Bi-directional pivot door*	+ € 200
	Pannello scorrevole Sliding panel	+ € 100
	Pannello girevole Pivoting panel	+ € 100

\* porte disponibili fino L1000. Serratura compresa nel prezzo maniglia  
\* doors available up to L 1000. Lock included in the handle price

### 4 MANIGLIE / HANDLES

Tipo pannello Panel type	Tipo di apertura Opening type	Maniglia Handle	Solo maniglia Only handle	Chiave patent Patent key	Nottolino Latch free/busy	Chiave Yale Yale key
Vetro Glass	Porta bilico battente o Porta bilico bidirezionale Hinged pivot door or Bi-directional pivot door	Etna	+ € 250	-	+ € 290	+ € 350
		Vesuvio	+ € 270	-	+ € 300	+ € 370
		Vulcano	+ € 250	-	+ € 290	+ € 350
	Pannello scorrevole Sliding panel	Piave	+ € 100	+ € 150 **	+ € 150 **	-
		Triennale	+ € 100	-	-	-
		Pannello girevole* Pivoting panel*	Piave	+ € 100	-	-
Triennale	+ € 100		-	-	-	

\*per pannelli pivotanti è possibile ordinare 0, 1 o 2 maniglie. In caso di 1 maniglia specificare se posizionarla a destra o a sinistra  
\*for pivoting panels it is possible to order 0, 1 or 2 handles. In case of 1 handle, specify to position it on the right or on the left

\*\*opzione disponibile solo per pannello scorrevole, necessita di un profilo di battuta con incontro  
\*\*option only available for sliding panel, requires terminal doorjamb with striker

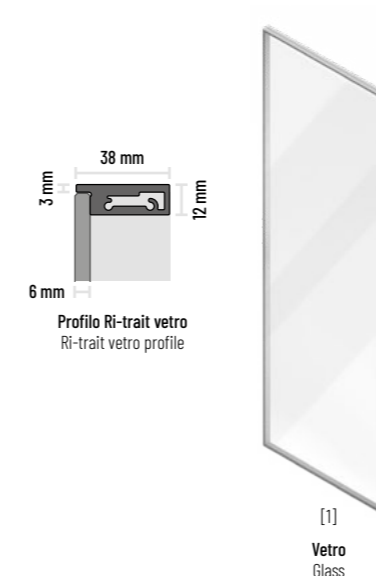

### CODICI PORTE / DOORS CODES

Tipo pannello Panel type	Pannello fisso per parete divisoria Fixed panel for wall development	Porta bilico battente per parete divisoria Hinged pivot door for wall development	Porta bilico bidirezionale per parete divisoria Bi-directional pivot door for wall development	Pannello scorrevole Sliding panel	Pannello girevole Pivoting panel
[1]	TR-F1	TR-P1BT	TR-P1B	TR-A1	TR-A1P

### Maniglie porta bilico battente o bidirezionale Hinged pivot door or bi-directional pivot door handles

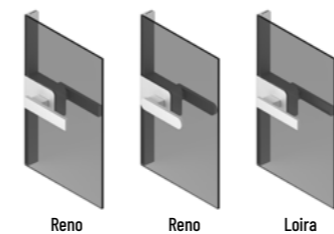

Reno

Reno

Loira

### Maniglie pannelli scorrevoli e girevoli Sliding panels or pivoting panels handles

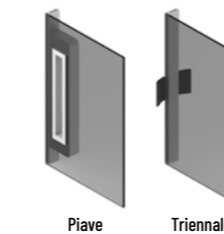

Piave

Triennale

### CODICI PORTE / DOORS CODES

Maniglia Handle	Solo maniglia Only handle	Chiave Patent Patent key	Nottolino Latch free/busy	Chiave Yale Yale key
Etna	RT-FM1	-	RT-FM2	RT-FM3
Vesuvio	RT-FM100	-	RT-FM200	RT-FM300
Vulcano	RT-FM10	-	RT-FM20	RT-FM30
Piave*	Q	Q1	Q2	-
Triennale	TR1	-	-	-
Piave**	QX	-	-	-

\* maniglia per pannelli scorrevoli / handle for sliding panel

\*\* maniglia per pannelli girevoli / handle for pivoting panel

# Sistema parete divisoria Ri-trait 8b

## Ri-trait 8b partition wall system

### 1 PANNELLI RI-TRAIT 8B FISSI / RI-TRAIT 8B FIXED PANELS

Tipo pannello Panel type	Finitura base Base finishing		L 500 - L 700	L 700 - L 900	L 900 - L 1100	L 1100 - L 1300	L 1300 - L 1500
Vetro Glass	Vetro Cat. A Glass Cat. A	H < 2100	€ 1.688	€ 1.908	€ 2.093	€ 2.290	€ 2.463
		H 2100 - H 2300	€ 1.750	€ 1.990	€ 2.190	€ 2.396	€ 2.648
	Finitura alluminio anodizzato / Anodized aluminum finishing	H 2300 - H 2500	€ 1.850	€ 2.089	€ 2.301	€ 2.566	€ 2.746
		H 2500 - H 2700	€ 1.890	€ 2.168	€ 2.399	€ 2.695	€ 2.855
		H 2700 - H 3000	€ 1.990	€ 2.265	€ 2.490	€ 2.790	€ 2.998
	H 3000 - H 3200	€ 2.080	€ 2.360	€ 2.590	€ 2.918	€ 3.090	

### 2 FINITURE / FINISHINGS

Tipo pannello Panel type	Finitura Finishing	P. 30					
Vetro Glass	Vetro Cat. B / Glass Cat. B		+ 5%	+ 7%	+ 7%	+ 7%	+ 10%
	Vetro Cat. C / Glass Cat. C		+ 10%	+ 12%	+ 15%	+ 15%	+ 20%
	Vetro Cat. D / Glass Cat. D		+ 15%	+ 20%	+ 25%	+ 30%	+ 30%

### 3 CONVERSIONE IN PANNELLO PORTA CONVERSION TO DOOR PANEL

Tipo pannello Panel type	Tipo di apertura Opening type	
Vetro Glass	Porta bilico battente* Hinged pivot door*	+ € 200
	Porta bilico bidirezionale* Bi-directional pivot door*	+ € 200
	Pannello scorrevole Sliding panel	+ € 100
	Pannello girevole Pivoting panel	+ € 100

\* porte disponibili fino L1000. Serratura compresa nel prezzo maniglia  
\* doors available up to L 1000. Lock included in the handle price

### 4 MANIGLIE / HANDLES

Tipo pannello Panel type	Tipo di apertura Opening type	Maniglia Handle	Solo maniglia Only handle	Chiave patent Patent key	Nottolino Latch free/busy	Chiave Yale Yale key
Vetro Glass	Porta bilico battente o Porta bilico bidirezionale Hinged pivot door or Bi-directional pivot door	Etna	+ € 250	-	+ € 290	+ € 350
		Vesuvio	+ € 270	-	+ € 300	+ € 370
		Vulcano	+ € 250	-	+ € 290	+ € 350
	Pannello scorrevole Sliding panel	Reno	+ € 150	-	-	-
		Loira	+ € 150	+ € 250 **	+ € 250 **	-
		Triennale	+ € 100	-	-	-
		Adige 200mm	+ € 100	-	-	-
		Triennale	+ € 100	-	-	-

\*per pannelli pivotanti è possibile ordinare 0, 1 o 2 maniglie. In caso di 1 maniglia specificare se posizionarla a destra o a sinistra

\*\*per pannelli pivotanti è possibile ordinare 0, 1 o 2 maniglie. In caso di 1 maniglia specificare se posizionarla a destra o a sinistra

\*\*opzione disponibile solo per pannello scorrevole, necessita di un profilo di battuta con incontro

\*\*option only available for sliding panel, requires terminal doorjamb with striker

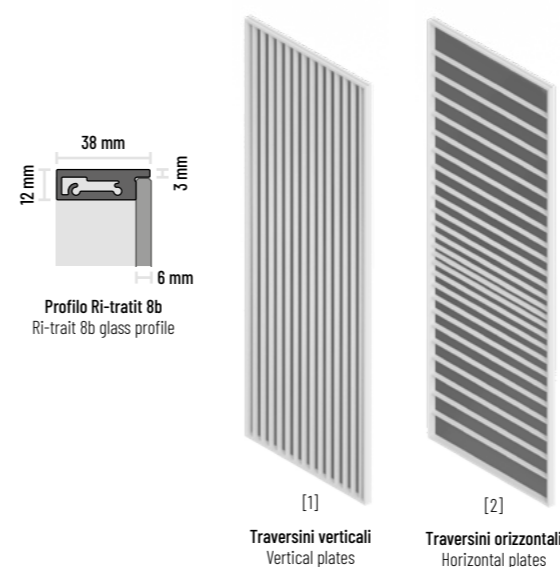

### CODICI PORTE / DOORS CODES

Tipo pannello Panel type	Pannello fisso per parete divisoria Fixed panel for wall development	Porta bilico battente per parete divisoria Hinged pivot door for wall development	Porta bilico bidirezionale per parete divisoria Bi-directional pivot door for wall development	Pannello scorrevole Sliding panel	Pannello girevole Pivoting panel
[1]	TR-8BV-RF	TR-8BV-RBT	TR-8BV-RB	TR-8BV-R	TR-8BV-RP
[2]	TR-8BH-RF	TR-8BH-RBT	TR-8BH-RB	TR-8BH-R	TR-8BH-RP

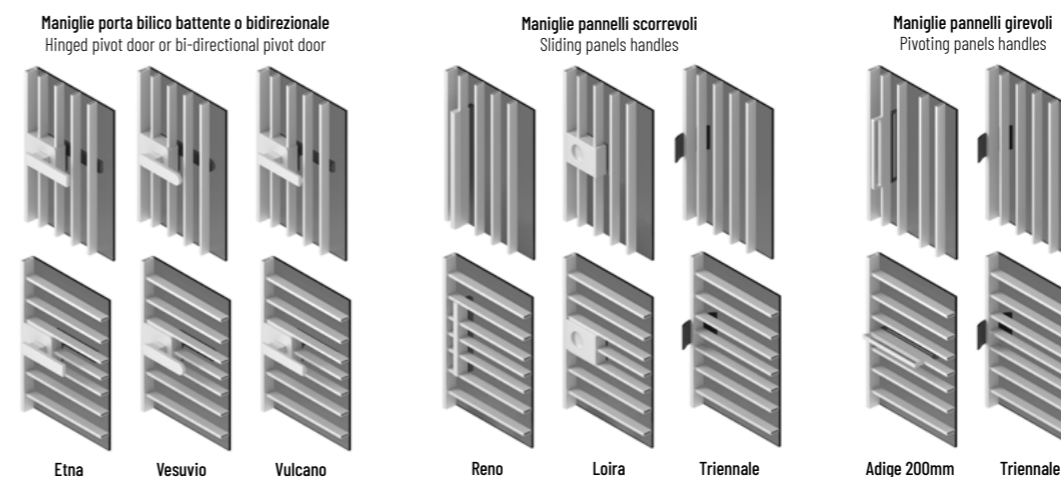

### CODICI PORTE / DOORS CODES

Maniglia Handle	Solo maniglia Only handle	Chiave Patent Patent key	Nottolino Latch free/busy	Chiave Yale Yale key
Etna	RT-FM4	-	RT-FM5	RT-FM6
Vesuvio	RT-FM400	-	RT-FM500	RT-FM600
Vulcano	RT-FM40	-	RT-FM50	RT-FM60
Reno verticale / vertical	K2	-	-	-
Reno orizzontale / horizontal	K1	-	-	-
Loira	RT1	RT2	RT3	-
Adige 200mm	MX	-	-	-
Triennale	TR1	-	-	-



# Struttura sistema telaio parete divisoria

## Frame system partition wall structure

### Elementi struttura / Structure elements

#### BINARIO SUPERIORE / UPPER RAIL

Tipologia binario Rail typology	1 via 1 way	2 vie 2 ways	2 vie 2 ways	2 vie 2 ways
<b>Binario Evo a soffitto</b> Ceiling Evo rail	€/ml 110	€/ml 150	EQ-BS1	EQ-BS2

#### ACCESSORI BINARIO / RAIL ACCESSORIES

Tipologia binario Rail typology	1 via 1 way	2 vie 2 ways	2 vie 2 ways	2 vie 2 ways
<b>Trave da incasso per binario Evo a soffitto</b> Built-in system for ceiling Evo rail	€/ml 55	€/ml 60	EQ-TB10	EQ-TB20
<b>Coppia di tappi di chiusura per binario Evo a soffitto</b> Pair of plugs to cover the sides of the ceiling Evo rail	€ 80	€ 80	EQ-T1	EQ-T2
<b>Profilo di battuta (parete perpendicolare al binario)</b> Terminal doorjamb (wall perpendicular to the rail)	€ 190	-	QD-ST1	-
<b>Profilo di battuta (parete parallela al binario)</b> Terminal doorjamb (wall parallel to the rail)	€ 190	€ 190	QD-SP1	QD-SP2

#### PROFILI VERTICALI IN ALLUMINIO / PROFILI VERTICALI IN ALLUMINIO

Elemento Element	H < 2300	H 2300 - H 2700	H 2300 - H 3200	Codici Codes
<b>Nodo di collegamento per incroci a 90°</b> Connecting node for 90° crossings	€ 150	€ 170	€ 180	AWDC011

### Elementi angolari speciali / Special corner elements

#### 1 PANNELLI QUADRA FISSI CON ANGOLO VIVO / QUADRA FIXED PANELS WITH SHARP CORNERS

Tipo pannello Panel type	Finitura base Base finishing	Angolo L L angle	Angolo T T angle	Angolo L L angle	Angolo T T angle	
<b>Vetro singolo</b> Single glass	<b>Vetro Cat. A</b> Glass Cat. A	H < 2100	€ 1.220	€ 1.410	QD-C1	QD-C3
		H 2100 - H 2300	€ 1.270	€ 1.430		
		H 2300 - H 2500	€ 1.310	€ 1.470		
		H 2500 - H 2700	€ 1.350	€ 1.530		
		H 2700 - H 3000	€ 1.390	€ 1.590		
H 3000 - H 3200	€ 1.490	€ 1.640				

#### 2 FINITURE / FINISHINGS

Tipo pannello Panel type	Finitura Finishing	P. 24
<b>Vetro singolo</b> Single glass	<b>Vetro Cat. B</b> / Glass Cat. B	+ 13%
	<b>Vetro Cat. C</b> / Glass Cat. C	+ 19%
	<b>Vetro Cat. D</b> / Glass Cat. D	+ 40%
	<b>Vetro Cat. E</b> / Glass Cat. E	+ 65%

# BOISERIE

## BOISERIE

Le Boiserie Albed permettono di rivestire le pareti con una vasta gamma di materiali e finiture, dal vetro al legno, fino alle lastre ceramiche. I rivestimenti a parete permettono di personalizzare lo spazio garantendo performance altrimenti impossibili sia in termini di pulizia e resistenza, che di selezione di finiture.

Albed ha sviluppato due approcci per rispondere alle necessità progettuali, individuando una soluzione a spessori ridotti e una soluzione a pannelli removibili. Entrambe le soluzioni Boiserie Albed sono compatibili con diversi stipiti del nostro sistema prodotto che permettono una vasta integrazione di soluzioni filomuro ed effetto filomuro in modo da offrire risposte ad un'ampia gamma di necessità di installazione.

Albed Boiseries allow to cover the walls of a wide range of materials and finishings, from glass to wood, up to ceramic slabs. The wall coverings allow to customize the space ensuring otherwise impossible performances both in terms of cleanliness and resistance, and in terms of finishings selection.

Albed has developed two approaches to respond to the project plannings, by identifying a solution with reduced thicknesses and a solution with removable panels. Both Albed Boiseries solutions are compatible with different jambs of our product system which allow a wide integration of flush door solution and flush door effect in order to offer answers to a wide range to installation requirements..

### Sistema prodotto / Product system

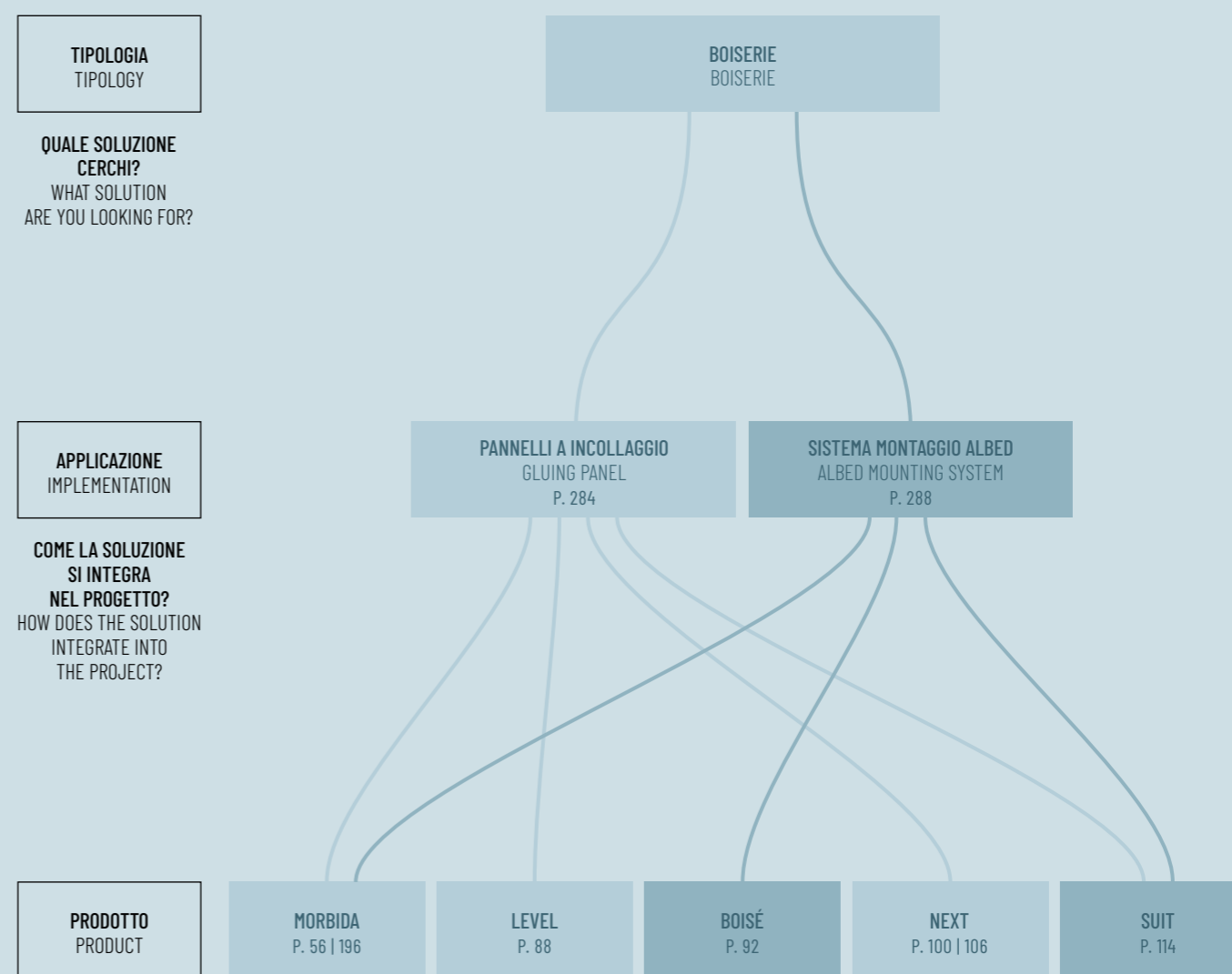

# Boiserie con pannelli a incollaggio

## Boiserie with gluing panels

### Pannelli incollati su parete / Panels glued to the wall

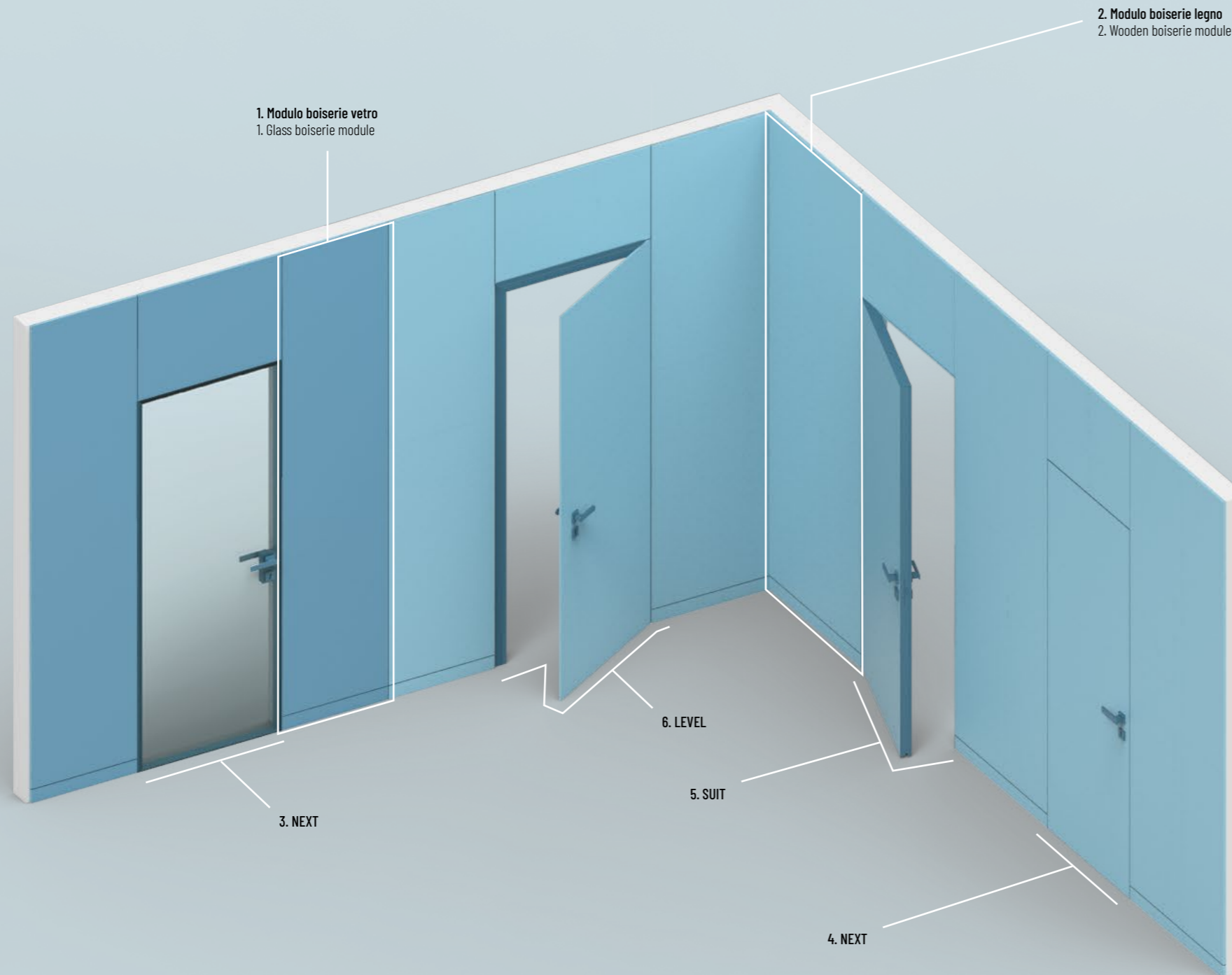

Il sistema Boiserie Albed ad incollaggio è un sistema di rivestimento a parete fisso che favorisce il contenimento degli spessori, pur garantendo stabilità, isolamento acustico e termico e integrazione con una vasta gamma di stipiti e porte filomuro o effetto filomuro. La sezione di 18mm progettata da Albed si compone di pannelli di supporto, anche certificati FSC, e una gamma variabile di vetri e finiture nobili in legno per soddisfare le diverse esigenze dell'interior design, dal mondo residenziale a quello dell'ospitalità e del mondo professionale.

Albed gluing System is a fixed wall covering system that supports the containment of thicknesses, while ensuring stability, sound and thermal insulation and integration with a wide range of jambs and flush doors or flush effect doors. The 18mm section designed by Albed consists of support panels, also FSC certified, and a variable range of glasses and noble wood finishings to meet the different requirements of the interior design, from the residential to the hospitality world and to the professional world.

## Componenti / Components

### BOISERIE A INCOLLAGGIO / BOISERIE GLUING

1. Modulo boiserie vetro  
1. Glass boiserie module
2. Modulo boiserie legno  
2. Wooden boiserie module

### PORTE / DOORS

3. Porta singola filomuro cerniere nascoste, Next 50mm telaio alluminio, a tirare, apertura a sinistra  
3. Single flush door with concealed hinges, Next 50mm aluminium frame, to pull, left opening
4. Porta singola filomuro cerniere nascoste, Next 58mm pannello legno, a spingere, apertura a destra  
4. Single flush door with concealed hinges, Next 58mm wooden panel, to push, right opening
5. Porta singola filomuro cerniere nascoste, Suit con rivestimento in legno, a tirare, apertura a sinistra  
5. Single flush door with concealed hinges, Suit with wooden coating, to pull, left opening
6. Porta singola effetto filomuro, Level pannello legno, a tirare, apertura a destra  
6. Single flush-effect door, Level wooden panel, to pull, right opening

Informazioni generali / General informations  
 Porte battenti con cornice / Hinged door and frame  
 Porte battenti filomuro / Flush-effect door  
 Porte filomuro / Flush door  
 Porte effetto filomuro / Flush-effect door  
 Porte senza falso telaio / Door w/o basic door frame  
 Porte a scomparsa / Pocket door  
 Porte a scomparsa / Pocket door  
 Pannelli scorrevoli o girevoli / Sliding or pivoting panels  
 Pannelli scorrevoli o girevoli / Sliding or pivoting panels  
 Pareti divisorie / Partition wall  
 Pareti divisorie / Partition wall  
 Boiserie / Boiserie  
 Boiserie / Boiserie  
 Cabine armadio / Walk-in closet  
 Cabine armadio / Walk-in closet  
 Librerie / Bookcase  
 Librerie / Bookcase  
 Tavoli / Table  
 Tavoli / Table

Informazioni generali / General informations  
 Porte battenti con cornice / Hinged door and frame  
 Porte battenti filomuro / Flush-effect door  
 Porte filomuro / Flush door  
 Porte effetto filomuro / Flush-effect door  
 Porte senza falso telaio / Door w/o basic door frame  
 Porte a scomparsa / Pocket door  
 Porte a scomparsa / Pocket door  
 Pannelli scorrevoli o girevoli / Sliding or pivoting panels  
 Pannelli scorrevoli o girevoli / Sliding or pivoting panels  
 Pareti divisorie / Partition wall  
 Pareti divisorie / Partition wall  
 Boiserie / Boiserie  
 Boiserie / Boiserie  
 Cabine armadio / Walk-in closet  
 Cabine armadio / Walk-in closet  
 Librerie / Bookcase  
 Librerie / Bookcase  
 Tavoli / Table  
 Tavoli / Table

# Sviluppo boiserie a incollaggio

## Boiserie gluing development

### PANNELLI BOISERIE / BOISERIE PANELS

Tipo pannello Panel type	Finitura Finishing	Prezzo Price	Codici / Codes		
			6mm lastra in vetro + 12mm pannello di supporto 6mm glass board + 12mm support panel	4mm lastra in vetro + 14mm pannello di supporto 4mm glass board + 14mm support panel	18mm pannello con finitura 18mm finishing panel
Modulo boiserie vetro* Glass boiserie module*	Vetro opaco cat. C Opaque glass cat. C	€/mq 550,00	ABBI001	ABBI002	-
	Vetro opaco cat. D Opaque glass cat. D	€/mq 590,00			
Modulo boiserie legno Wooden boiserie module	Essenza legno Wooden essence	€/mq 490,00	-	-	ABBI003

\*È possibile realizzare a progetto boiserie con vetri con reti e tessuti (vetro cat. E). Per dettagli, prezzi e compatibilità contattare l'ufficio commerciale.

\*It is possible to realize be-spoke boiserie with "glasses with fabric and mesh" (glass cat. E). For details, prices and compatibility contact the sales office

La larghezza moduli è calcolata per avere il minimo numero di divisioni uguali, per divisioni personalizzate è previsto un sovrapprezzo di + € 80

The module width is calculated in order to have the minimum quantity of equal divisions, for customized divisions there is a surcharge of + € 80

Altezza massima modulo: H 3200

Larghezza massima modulo: L 1200

Standard module height: H 2300 - H 3200

Max module width: L 1200

### PORTE COMPATIBILI / COMPATIBLE DOORS

Tipologia Typology	Stipite Jamb	Prodotto Product	Pagina listino Page price book	Compatibilità / Compatibilities		
				6mm lastra in vetro + 12mm pannello di supporto 6mm glass board + 12mm support panel	4mm lastra in vetro + 14mm pannello di supporto 4mm glass board + 14mm support panel	18mm pannello con finitura 18mm finishing panel
Porte battenti con cornice Hinged door and frame	Stipite Morbida Morbida jamb	MORBIDA	P. 56	-	Compatibile / Compatible	Compatibile / Compatible
		NEXT 50MM	P. 100	-	Compatibile / Compatible	Compatibile / Compatible
Porte filomuro Flush door	Filomuro cerniera nascosta Flush door with concealed hinges	NEXT 58MM	P. 106	-	Compatibile / Compatible	Compatibile / Compatible
		SUIT	P. 114	Compatibile / Compatible	-	Compatibile / Compatible
		Filomuro bilico Pivoting flush door	SUIT	P. 114	Compatibile / Compatible	-
Porte effetto filomuro Flush-effect door	Effetto filomuro bilico Pivoting flush door effect	LEVEL	P. 88	-	Compatibile / Compatible	Compatibile / Compatible
Porte a scomparsa Pocket door	Stipite Morbida Morbida jamb	MORBIDA	P. 196	-	Compatibile / Compatible	Compatibile / Compatible

# Dettagli boiserie a incollaggio

## Boiserie gluing details

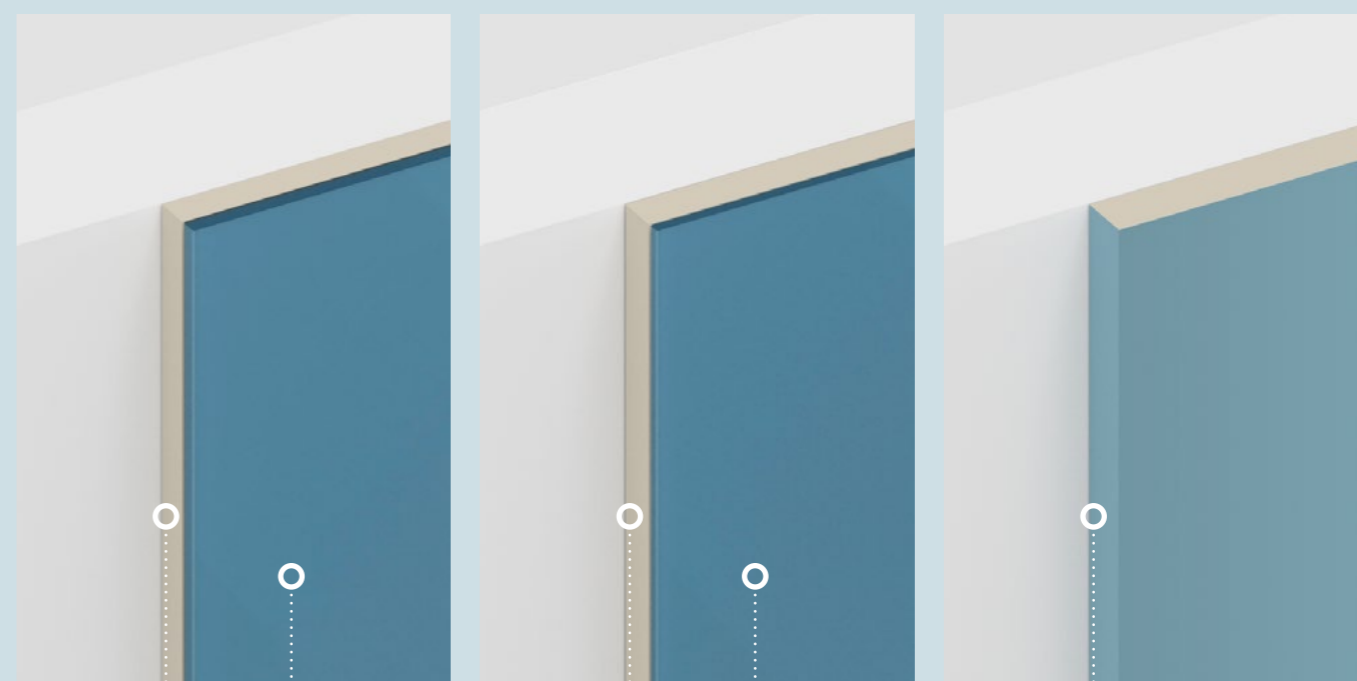
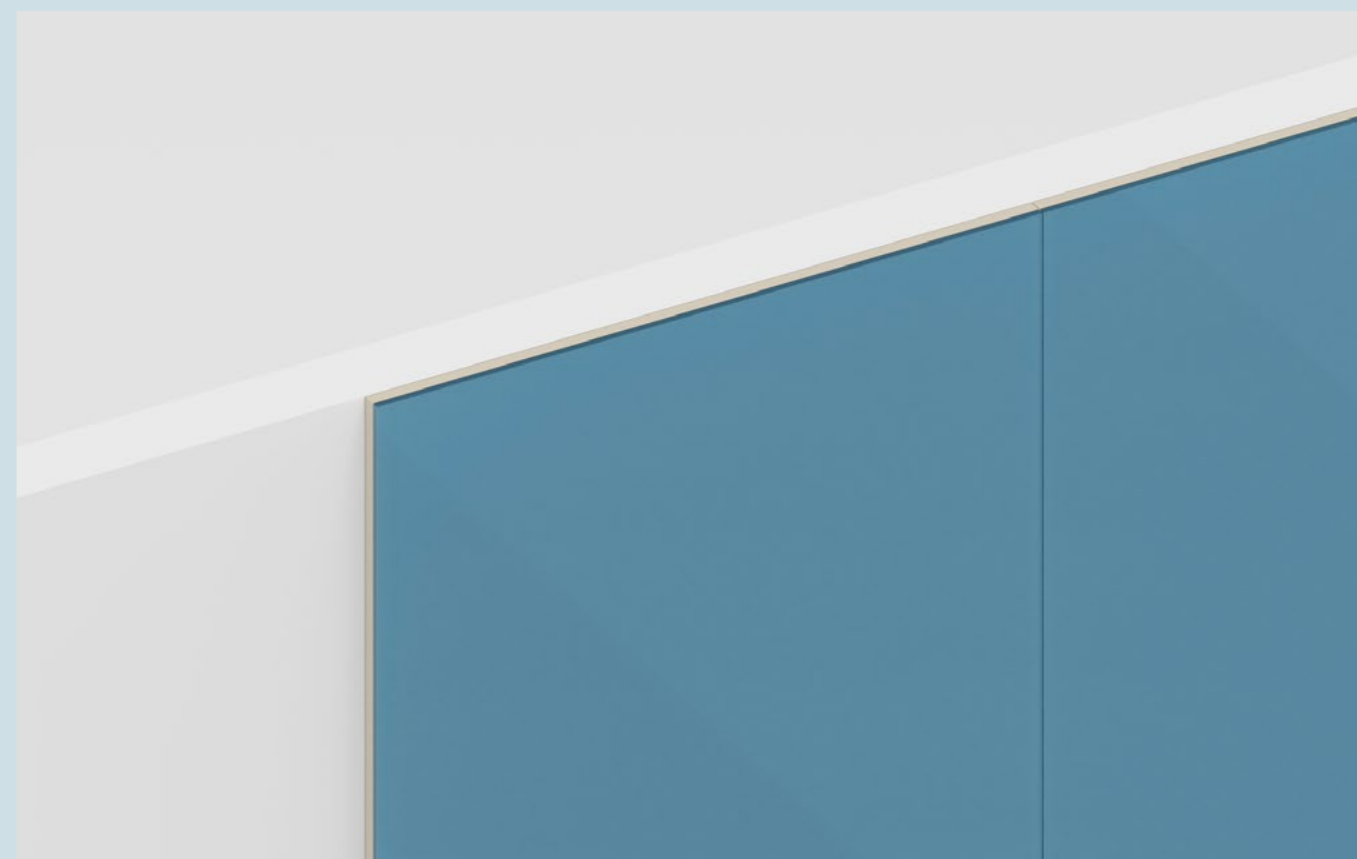

12mm pannello di supporto  
12mm support panel

6mm lastra in vetro  
6mm glass board

14mm pannello di supporto  
14mm support panel

4mm lastra in vetro  
4mm glass board

18mm pannello con finitura  
18mm finishing panel



# Boiserie sistema a montaggio Albed

## Boiserie Albed mounting system

### Pannelli montati su struttura / Panels mounted on structure

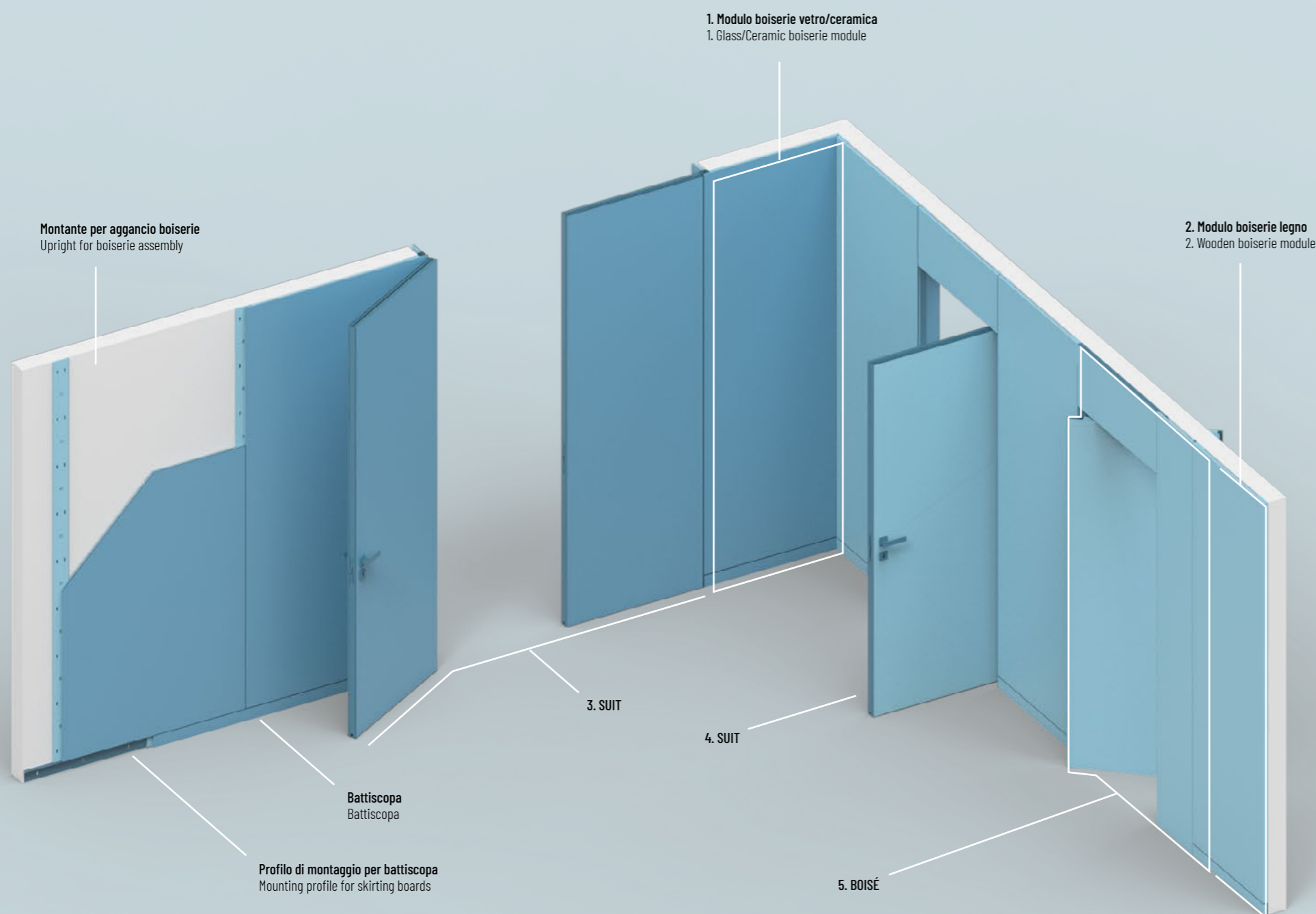

Il sistema Boiserie Albed a montaggio è un sistema di rivestimento a parete removibile che favorisce una gestione dinamica degli spazi, rendendo tutti i pannelli removibili in pochi secondi, grazie ad un sistema di agganci stabile, semplice e affidabile. Questo sistema permette di installare boiserie in vetro, legno e ceramica completamente removibili e ispezionabili con una sezione di soli 30mm dalla parete di appoggio. La Boiserie Albed incrementa l'isolamento acustico e termico ed è integrabile con una vasta gamma di stipiti e porte filomuro o effetto filomuro. I pannelli di supporto possono essere certificati FSC e si accompagnano ad una vasta gamma di vetri, finiture nobili in legno o lastre ceramiche fornite dal cliente per soddisfare le diverse esigenze dell'interior design, dal mondo residenziale a quello dell'ospitalità e del mondo professionale.

Albed mounting System is a removable wall covering system that supports a dynamic management of spaces, making the panels removable in few seconds, thanks to a stable, easy and reliable hooking system. This system allows to install glass, wood and ceramic boiserie which are completely removable and inspectable with a section of only 30 mm from the support wall. Albed Boiserie increases sound and thermal insulation and can be integrated with a wide range of jambs, flush doors or flush effect doors. The support panels can be FSC certified and can be matched to a wide range of glasses and noble wood finishings or ceramic slabs provided by the customer to meet the different requirements of interior design, from the residential to the hospitality world and to the professional world.

## Componenti / Components

### BOISERIE A MONTAGGIO / BOISERIE MOUNTING

1. Modulo boiserie vetro o ceramica  
1. Glass or ceramic boiserie module
2. Modulo boiserie legno  
2. Wooden boiserie module

### PORTE / DOORS

3. Porta doppia simmetrica filomuro cerniere nascoste, Suit con rivestimento in vetro o ceramica, a tirare, anta principale sinistra  
3. Double symmetrical flush door with concealed hinges, Suit with glass or ceramic coating, to pull, left main door
4. Porta singola filomuro bilico, Suit con rivestimento legno, a tirare, apertura a destra  
4. Single pivoting flush door, Suit with wooden coating, to pull, right opening
5. Porta singola effetto filomuro bilico, Boisè pannello legno, a spingere, apertura a sinistra  
5. Single pivoting flush-effect door, wooden panel, to push, left opening

# Sviluppo boiserie a montaggio

## Boiserie mounting development

### SISTEMA BOISERIE / BOISERIE SYSTEM

Tipo pannello Panel type	Finitura Finishing	Prezzo Price	Codici / Codes		
			6mm lastra in vetro o ceramica + 12mm pannello di supporto + 12mm montanti struttura 6mm glass or ceramic board + 12mm support panel + 12mm upright structure	4mm lastra in vetro o ceramica + 14mm pannello di supporto + 12mm montanti struttura 4mm glass or ceramic board + 14mm support panel + 12mm upright structure	18mm pannello con finitura + 12mm montanti struttura 18mm finishing panel + 12mm upright structure
Modulo boiserie vetro* Glass boiserie module*	Vetro opaco cat. C Opaque glass cat. C	€/mq 690,00	ABBG001	ABBG002	-
	Vetro opaco cat. D Opaque glass cat. D	€/mq 730,00			
Modulo boiserie ceramica Ceramic boiserie module	Predisposizione per ceramica cliente** Predisposition for customer ceramic**	€/mq 390,00	ABBG003	-	-
Modulo boiserie legno Wooden boiserie module	Essenza legno Wooden essence	€/mq 590,00	-	-	ABBG004

\*È possibile realizzare a progetto boiserie con vetri con reti e tessuti (vetro cat. E). Per dettagli, prezzi e compatibilità contattare l'ufficio commerciale.

\*it is possible to realize be-spoke boiserie with "glasses with fabric and mesh" (glass cat. E). For details, prices and compatibility contact the sales office

\*\*materiale e incollaggio a carico del cliente

\*\*material and gluing charged to the customer

La larghezza moduli è calcolata per avere il minimo numero di divisioni uguali, per divisioni personalizzate è previsto un sovrapprezzo di + € 80

The module width is calculated in order to have the minimum quantity of equal divisions, for customized divisions there is a surcharge of + € 80

Altezza massima modulo: H 3200

Larghezza massima modulo: L 1200

Max module height: H 3200

Max module width: L 1200

### PORTE / DOORS

Tipologia Typology	Stipite Jamb	Prodotto Product	Pagina listino Page price book	Compatibilità / Compatibilities		
				6mm lastra in vetro o ceramica + 12mm pannello di supporto + 12mm montanti struttura 6mm glass or ceramic board + 12mm support panel + 12mm upright structure	4mm lastra in vetro o ceramica + 14mm pannello di supporto + 12mm montanti struttura 4mm glass or ceramic board + 14mm support panel + 12mm upright structure	18mm pannello con finitura + 12mm montanti struttura 18mm finishing panel + 12mm upright structure
Porte battenti con cornice Hinged door and frame	Stipite soft Soft jamb	MORBIDA*	P. 56	-	Compatibile / Compatible	Compatibile / Compatible
Porte filomuro Flush door	Filomuro cerniera nascosta Flush door with concealed hinges	SUIT	P. 114	Compatibile / Compatible	-	Compatibile / Compatible
	Filomuro bilico Pivoting flush door	SUIT	P. 114	Compatibile / Compatible	-	Compatibile / Compatible
Porte effetto filomuro Flush-effect hinged door	Effetto filomuro bilico Pivoting flush door effect	BOISÉ	P. 92	-	Compatibile / Compatible	Compatibile / Compatible
Porte a scomparsa Pocket door	Stipite soft Soft jamb	MORBIDA*	P. 196	-	Compatibile / Compatible	Compatibile / Compatible

\*Boiserie sistema a montaggio Albed su Morbida battente o a scomparsa disponibile solo su progetto.

Per dettagli e prezzi contattare l'ufficio commerciale.

\*Boiserie Albed mounting system on Morbida hinged or pocket door available only on a project.

For details and prices contact the sales office.

# Dettagli boiserie a montaggio

## Boiserie mounting details

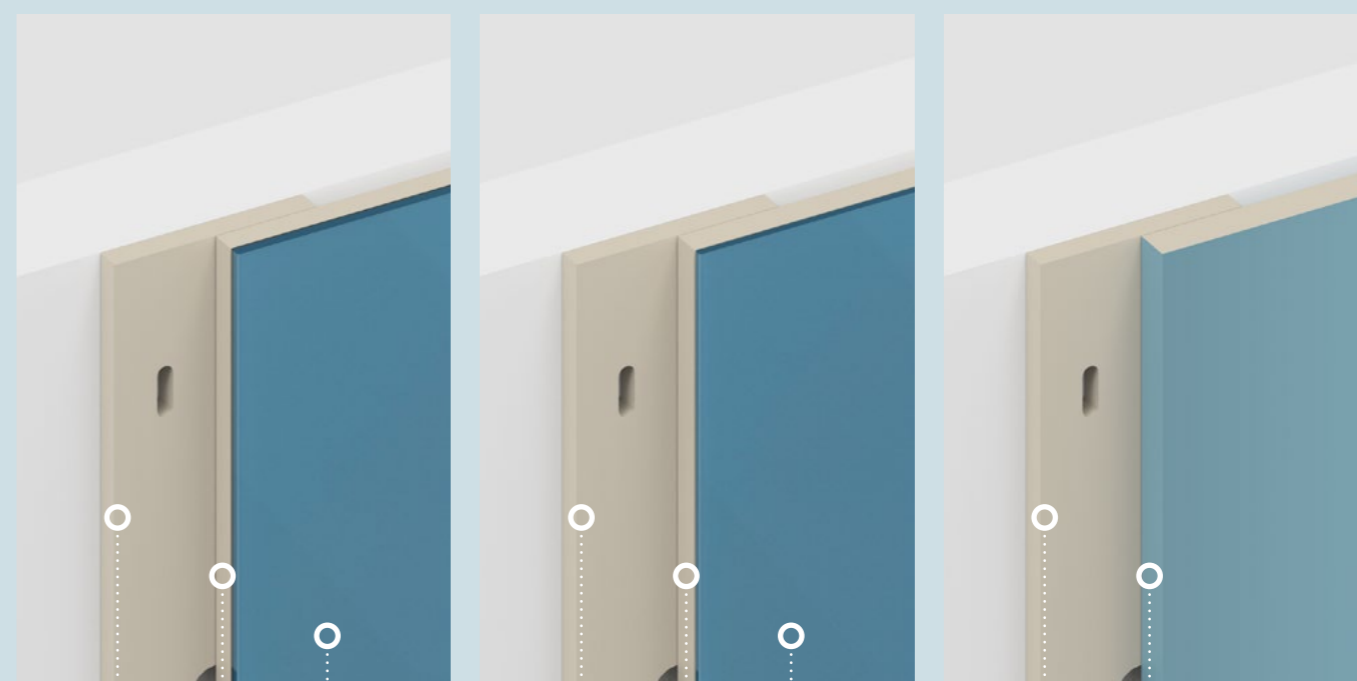
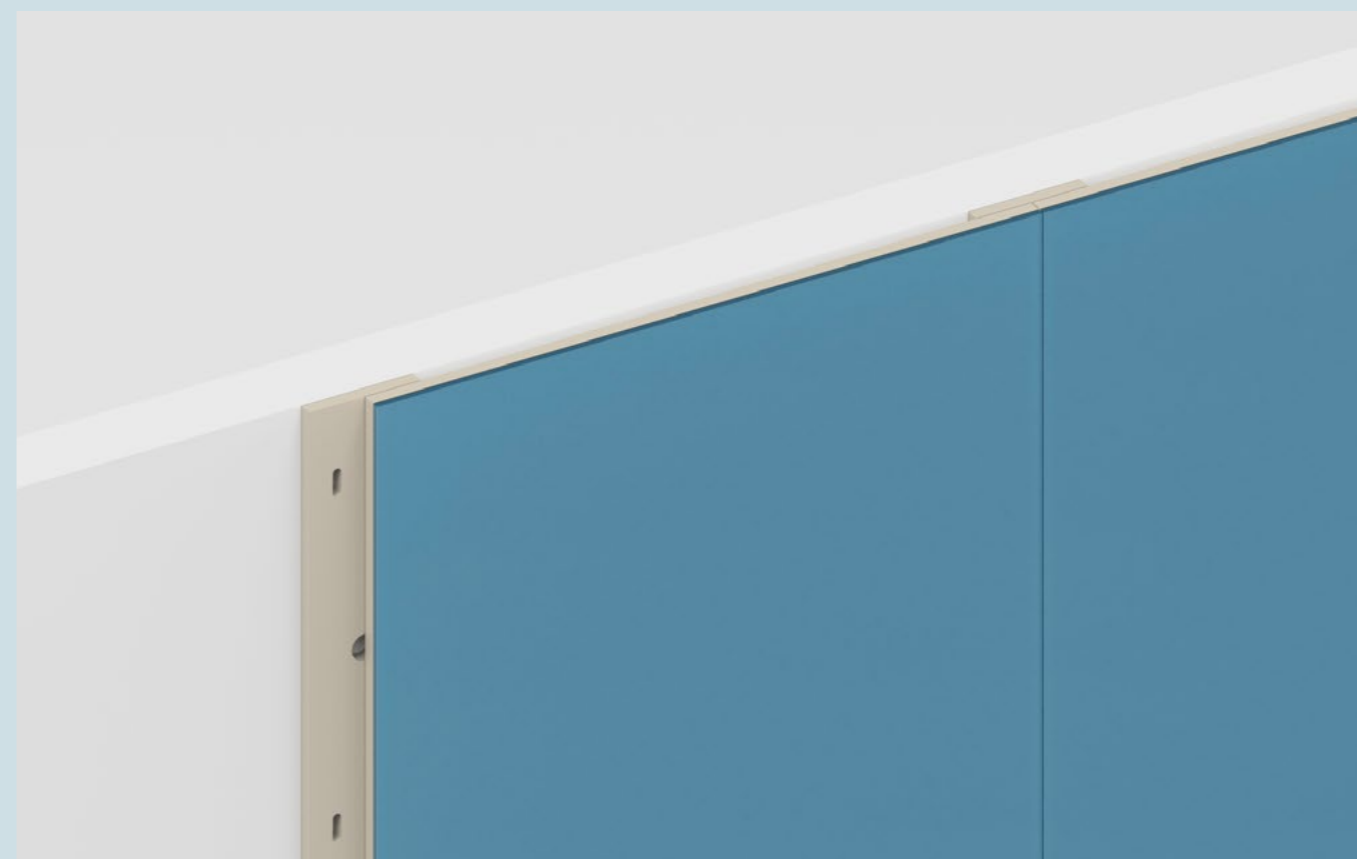

12mm montanti struttura  
12mm upright structure

12mm pannello di supporto  
12mm support panel

6mm lastra in vetro o ceramica  
6mm glass or ceramic board

12mm montanti struttura  
12mm upright structure

14mm pannello di supporto  
14mm support panel

4mm lastra in vetro  
4mm glass board

12mm montanti struttura  
12mm upright structure

18mm pannello con finitura  
18mm finishing panel

COM-  
PLE-  
MENTI

COM-  
PLE-  
MENTS



configura la tua cabina armadio  
su Albed.it

configure your walk-in closet  
on Albed.it

Montanti sul fondo / Upright on base

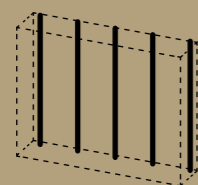

RI-VISTA | parete  
RI-VISTA | wall

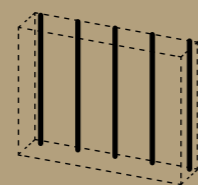

RI-VISTA | soffitto  
RI-VISTA | ceiling

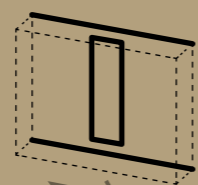

RI-VISTA | scorrevole  
RI-VISTA | sliding

Montanti frontali / Upright on front

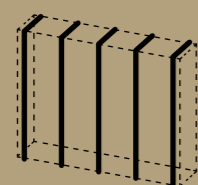

SOLO | parete  
SOLO | wall

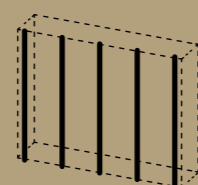

SOLO | soffitto  
SOLO | ceiling

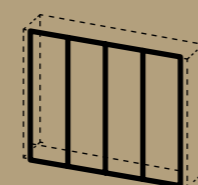

SOLO | nicchia  
SOLO | niche

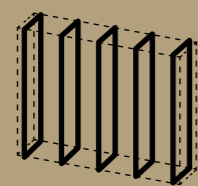

SOLO | freestanding  
SOLO | freestanding

# CABINE ARMADIO WALK-IN CLOSET

Sistemi modulari e personalizzabili che permettono di creare cabine armadio su misura per ogni esigenza progettuale, con altissima qualità costruttiva. Il sistema di montanti in alluminio permette l'integrazione con pannelli e finiture di diversi materiali per un'ampia configurabilità.

Modular, personalisable systems that can be used to create tailor-made walk-in closets for every design need, with very high quality construction. The system of aluminium uprights makes it possible to match panels and finishes in different materials for a wide configuration.

## Sistema prodotto / Product system

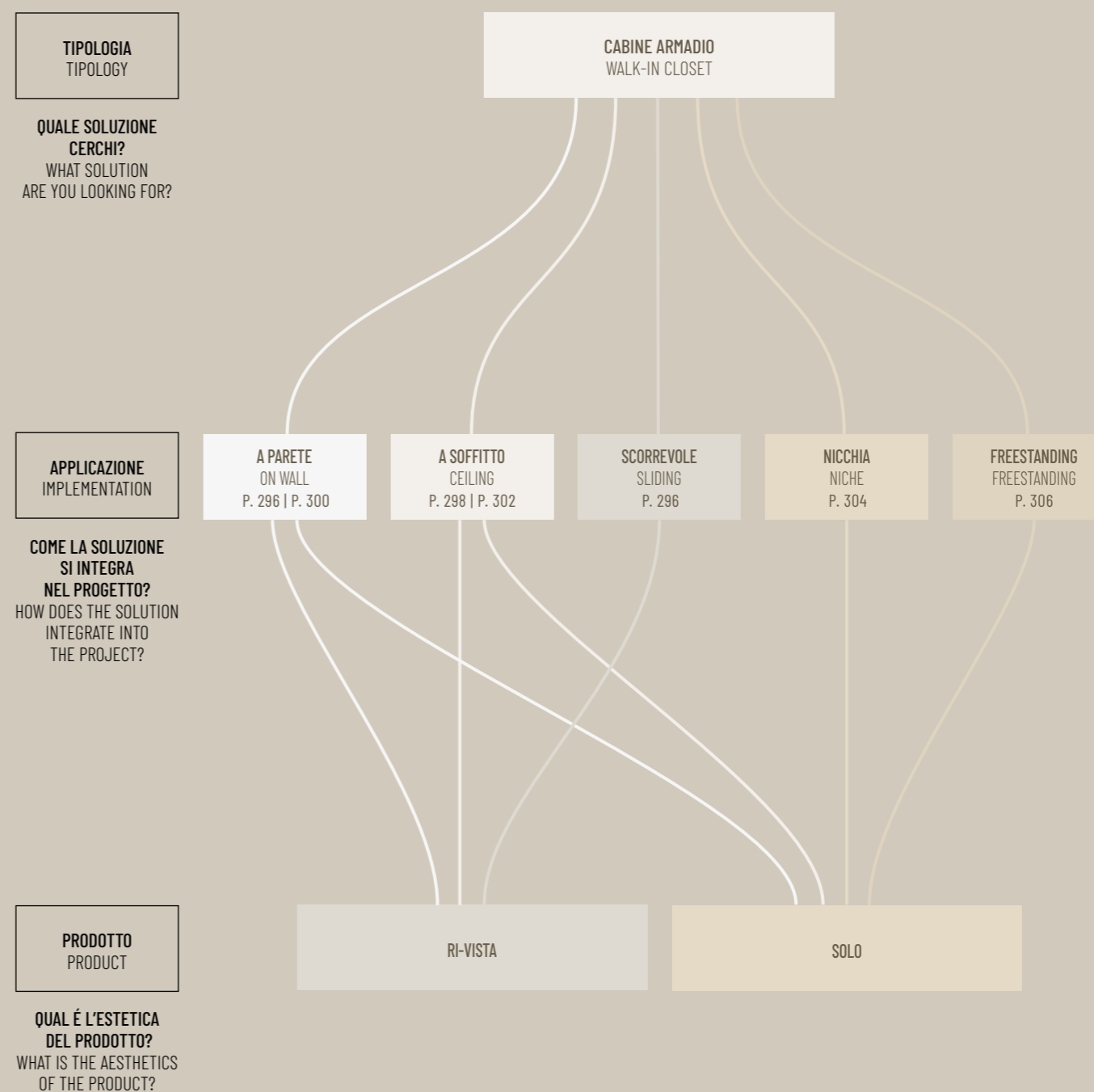

# Cabina armadio Ri-vista a parete

## Walk-in closet Ri-vista on wall

### Montanti sul fondo / Uprights on base

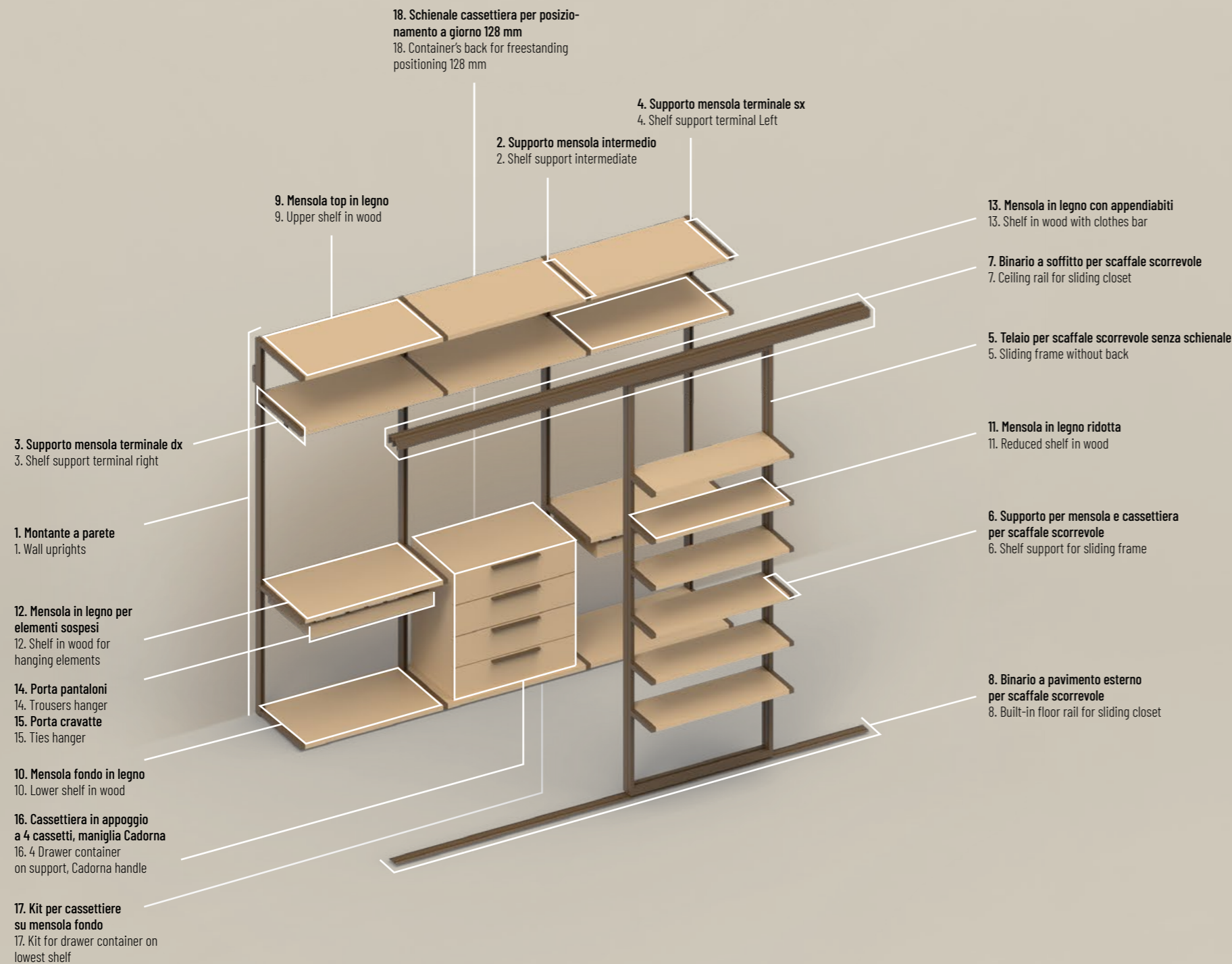

La scelta dei montanti sul fondo è la soluzione ideale quando si desidera una cabina armadio che può essere dotata di schienale. Gli elementi del sistema sono sospesi dal fondo, lasciando completamente libero il fronte della cabina armadio. Questa tipologia di montanti permette l'installazione anche in caso di soffitti molto alti fuori standard.

The base uprights choice is the ideal solution when you want to create a walk-in closet with an optional back panel. The system's elements are supported at the base, leaving the front of the walk-in closet completely free. This type of upright also makes installation possible when dealing with very high, non standard ceilings.

### Componenti / Components

#### STRUTTURA / FRAME

1. Montante a parete mod. RI-VISTA  
1. Wall uprights mod. RI-VISTA
2. Supporto mensola intermedio  
2. Shelf support intermediate
3. Supporto mensola terminale dx  
3. Shelf support terminal right
4. Supporto mensola terminale sx  
4. Shelf support terminal Left
5. Telaio per scaffale scorrevole senza schienale  
5. Sliding frame without back
6. Supporto per mensola e cassettiera per scaffale scorrevole  
6. Shelf support for sliding frame

#### BINARIO / RAIL

7. Binario a soffitto per scaffale scorrevole  
7. Ceiling rail for sliding closet
8. Binario a pavimento per scaffale scorrevole esterno  
8. Built-in floor rail for sliding closet

#### TOP / TOP

9. Mensola top in legno  
9. Upper shelf in wood

#### FONDO / BOTTOM

10. Mensola fondo  
10. Lower shelf in wood

#### ELEMENTI / ELEMENTS

11. Mensola in legno ridotta  
11. Reduced shelf in wood
12. Mensola in legno per elementi sospesi  
12. Shelf in wood for hanging elements
13. Mensola in legno con appendiabiti  
13. Shelf in wood with clothes bar
14. Porta pantaloni  
14. Trousers hanger
15. Porta cravatte  
15. Ties hanger
16. Cassettiera in appoggio a 4 cassetti, maniglia Cadorna  
16. 4 Drawer container on support, Cadorna handle

#### ACCESSORI / ACCESSORIES

17. Kit per cassettiera su mensola fondo  
17. Kit for drawer container on lowest shelf
18. Schienale cassettiera per posizionamento a giorno 128 mm  
18. Schienale cassettiera per posizionamento a giorno 128 mm

# Cabina armadio Ri-vista scorrevole

## Walk-in closet Ri-vista sliding

La soluzione scorrevole è un sistema ideale per aumentare la superficie attrezzata di una cabina armadio, oppure per suddividere in modo dinamico e versatile un ambiente con un sistema scaffalatura scorrevole.

The sliding solution is an ideal system for increasing the accessorised area of a walk-in closet, or to divide a room dynamically and flexibly, using an enclosing system made up of moveable modules.

# Cabina armadio Ri-vista a soffitto

## Walk-in closet Ri-vista on ceiling

### Montanti sul fondo / Uprights on base

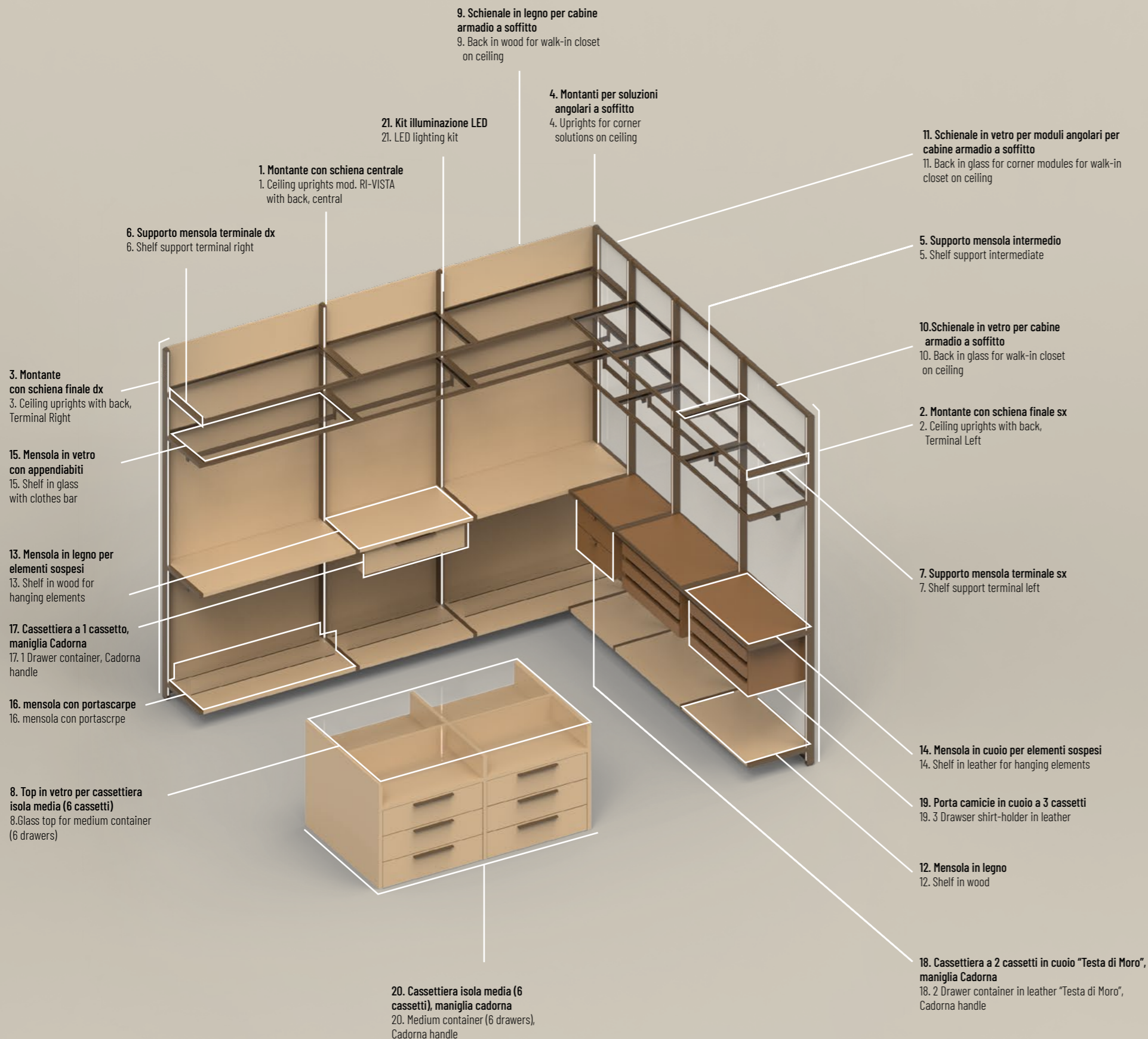

La scelta di una soluzione con montanti a soffitto è ideale quando si hanno delle altezze fino a 320 cm e si vuole utilizzare per la cabina armadio l'intera superficie da pavimento a soffitto. Questa cabina armadio permette di evitare qualsiasi interazione con le pareti verticali. In questa soluzione i montanti fissati a pavimento e a soffitto e permettono l'inserimento di schienali opzionali.

Opting for a ceiling upright solution is ideal when dealing with heights up to 320 cm and if you want the walk-in closet to go from floor to ceiling. This type of walk-in closet makes it possible to avoid any interaction with the vertical walls. For this solution, the uprights are fitted on the floor and on the ceiling, which allows for installing a back panel.

## Componenti / Components

### STRUTTURA / FRAME

- Montante a soffitto mod. RI-VISTA con schienale, centrale**  
Ceiling uprights mod. RI-VISTA with back, central
- Montante a soffitto mod. RI-VISTA con schienale, finale sx**  
Ceiling uprights mod. RI-VISTA with back, Terminal Left
- Montante a soffitto mod. RI-VISTA con schiena, finale dx**  
Ceiling uprights mod. RI-VISTA with back, Terminal Right
- Montanti per soluzioni angolari a soffitto mod. RI-VISTA con schiena**  
Uprights for corner solutions on ceiling mod. RI-VISTA with back
- Supporto mensola intermedio**  
Shelf support intermediate
- Supporto mensola terminale dx**  
Shelf support terminal right
- Supporto mensola terminale sx**  
Shelf support terminal left

### TOP / TOP

- Top in vetro per cassettiera isola media (6 cassetti)**  
Glass top for medium container (6 drawers)

### SCHIENALI / BACK

- Schienale in legno per cabine armadio a soffitto**  
Back in wood for walk-in closet on ceiling
- Schienale in vetro per cabine armadio a soffitto**  
Back in glass for walk-in closet on ceiling
- Schienale in vetro per moduli angolari per cabine armadio a soffitto**  
Back in glass for corner modules for walk-in closet on ceiling

### ELEMENTI / ELEMENTS

- Mensola in legno**  
Shelf in wood
- Mensola in legno per elementi sospesi**  
Shelf in wood for hanging elements
- Mensola in cuoio per elementi sospesi**  
Shelf in leather for hanging elements
- Mensola in vetro con appendiabiti**  
Shelf in glass with clothes bar
- Mensola portascarpe in legno**  
Shelf in wood for shoes
- Cassettiera a 1 cassetto, maniglia Cadorna**  
1 Drawer container, Cadorna handle
- Cassettiera a 2 cassetti in cuoio "Testa di Moro", maniglia Cadorna**  
2 Drawer container in leather "Testa di Moro", Cadorna handle
- Porta camicie in cuoio a 3 cassetti**  
3 Drawser shirt-holder in leather
- Cassettiera isola media (6 cassetti), maniglia Cadorna**  
Medium container (6 drawers), Cadorna handle

### ACCESSORI / ACCESSORIES

- Kit illuminazione LED**  
LED lighting kit

# Cabina armadio Solo a parete

## Walk-in closet Solo on wall

### Montanti frontali / Uprights on front

La scelta dei montanti frontali è la soluzione ideale quando si predilige una cabina armadio essenziale priva di schienale. I montanti frontali creano una suddivisione del fronte e sostengono tutti gli elementi del sistema, permettendo un'interazione minima con la parete di fondo. Questa tipologia di montanti permette l'installazione anche in caso di soffitti molto alti fuori standard.

The front uprights choice is the ideal solution when you want to opt for an essential walk-in closet without a back panel. The front uprights divide up the front and support all the system's elements, allowing minimal interaction with the back wall. This type of upright also makes installation possible when dealing with very high, non standard ceilings.

### Componenti / Components

#### STRUTTURA / FRAME

- 1. Montante a parete mod. SOLO**  
1. Wall uprights mod. SOLO
- 2. Supporto mensola intermedio**  
2. Shelf support intermediate
- 3. Supporto mensola terminale sx**  
3. Shelf support terminal left
- 4. Supporto mensola terminale dx**  
4. Shelf support terminal right

#### ELEMENTI / ELEMENTS

- 5. Mensola in legno**  
5. Shelf in wood
- 6. Mensola in legno per elementi sospesi**  
6. Shelf in wood for hanging elements
- 7. Mensola in legno con appendiabiti**  
7. Shelf in wood with clothes bar
- 8. Cassetiera a 2 cassetti, maniglia Cadorna**  
8. 2 Drawer container, Cadorna handle
- 9. Mobile a giorno**  
9. Open base unit
- 10. Cassetiera a 4 cassetti in appoggio, maniglia Triennale Testa di Moro**  
10. 4 Drawer container on support, Triennale "Testa di Moro" handle

#### ACCESSORI / ACCESSORIES

- 11. Kit per cassettiere su ruote**  
11. Kit for drawer container on wheel

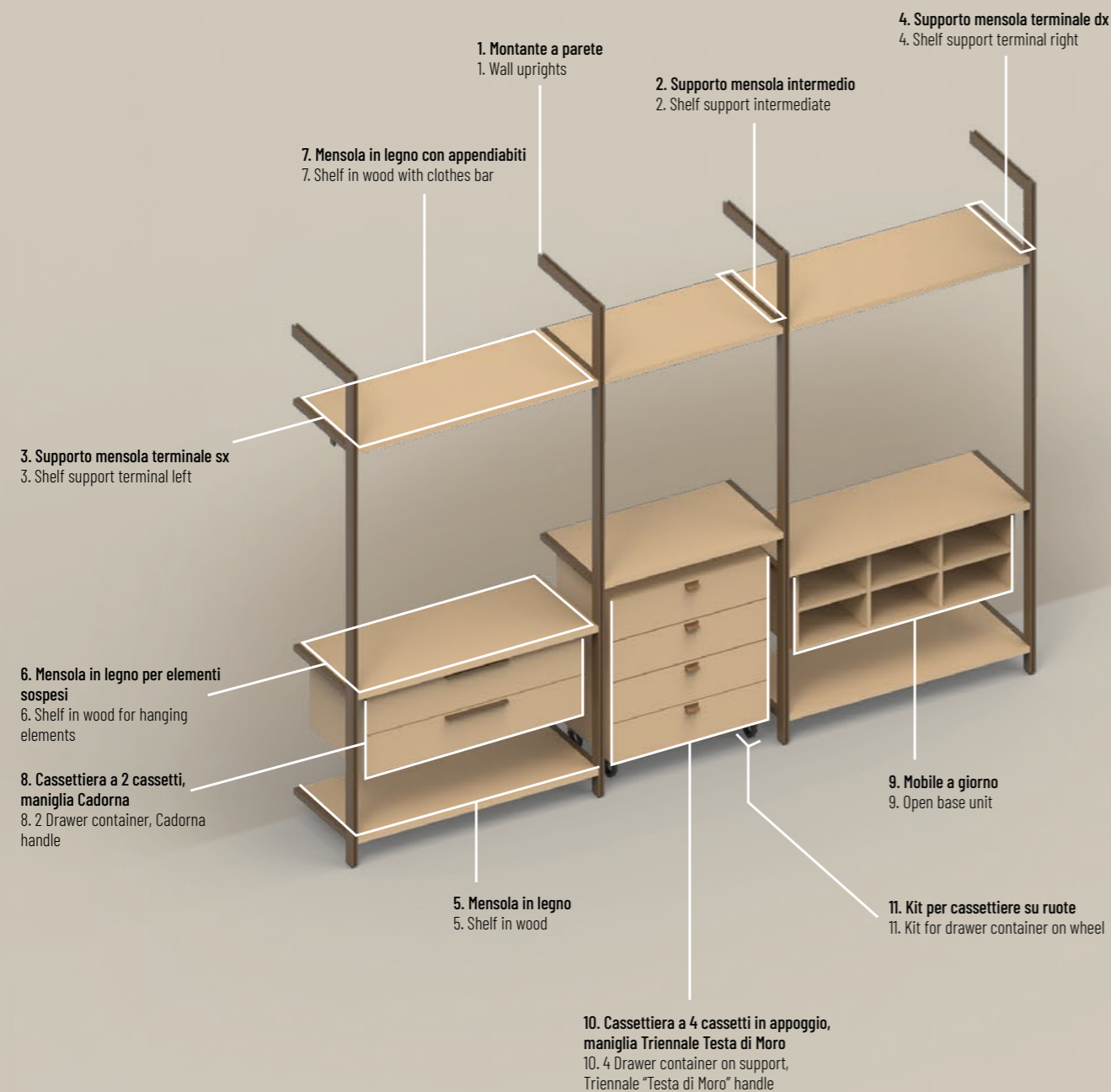

# Cabina armadio Solo a soffitto

## Walk-in closet Solo on ceiling

### Montanti frontali / Uprights on front

La scelta di una soluzione a montanti a soffitto è ideale quando si hanno delle altezze fino a 320 cm e si vuole utilizzare per la cabina armadio l'intera superficie terra cielo. Questa cabina armadio permette di evitare qualsiasi interazione con le pareti verticali. In questa soluzione i montanti vengono applicati frontalmente non permettendo l'installazione di uno schienale.

Opting for a ceiling upright solution is ideal when dealing with heights up to 320 cm and if you want the walk-in closet to go from floor to ceiling. This type of walk-in closet makes it possible to avoid any interaction with the vertical walls. For this solution, the uprights are fitted on the front, which does not allow for installing a back panel.

### Componenti / Components

#### STRUTTURA / FRAME

- 1. Montante a soffitto mod. SOLO**  
1. Ceiling uprights mod. SOLO
- 2. Montante per soluzione angolare**  
2. Montante per soluzione angolare
- 3. Supporto mensola intermedio**  
3. Shelf support intermediate
- 4. Supporto mensola terminale sx**  
4. Shelf support terminal left
- 5. Supporto mensola terminale dx**  
5. Shelf support terminal right

#### TOP / TOP

- 6. Top in vetro per cassettera isola piccola (3 cassetti)**  
6. Glass top for small container (3 drawers)

#### FONDO / BOTTOM

- 7. Mensola fondo in legno**  
7. Lower shelf in wood

#### ELEMENTI / ELEMENTS

- 8. Mensola in legno**  
8. Shelf in wood
- 9. Mensola in legno per elementi sospesi**  
9. Shelf in wood for hanging elements
- 10. Mensola in vetro con appendiabiti**  
10. Shelf in glass with clothes bar
- 11. Modulo angolare in legno**  
11. Corner module in wood
- 12. Modulo angolare in vetro con appendiabiti**  
12. Corner module in glass with clothes bar
- 13. Cassettera a 2 cassetti, maniglia Cadorna**  
13. 2 Drawer container, Cadorna handle
- 14. Porta camicie in legno a 3 cassetti**  
14. 3 Drawser shirt-holder
- 15. Cassettera isola piccola (3 cassetti) con piano in cuoio "Testa di Moro"**  
15. Small container island (3 drawers), top in leather "Testa di Moro"

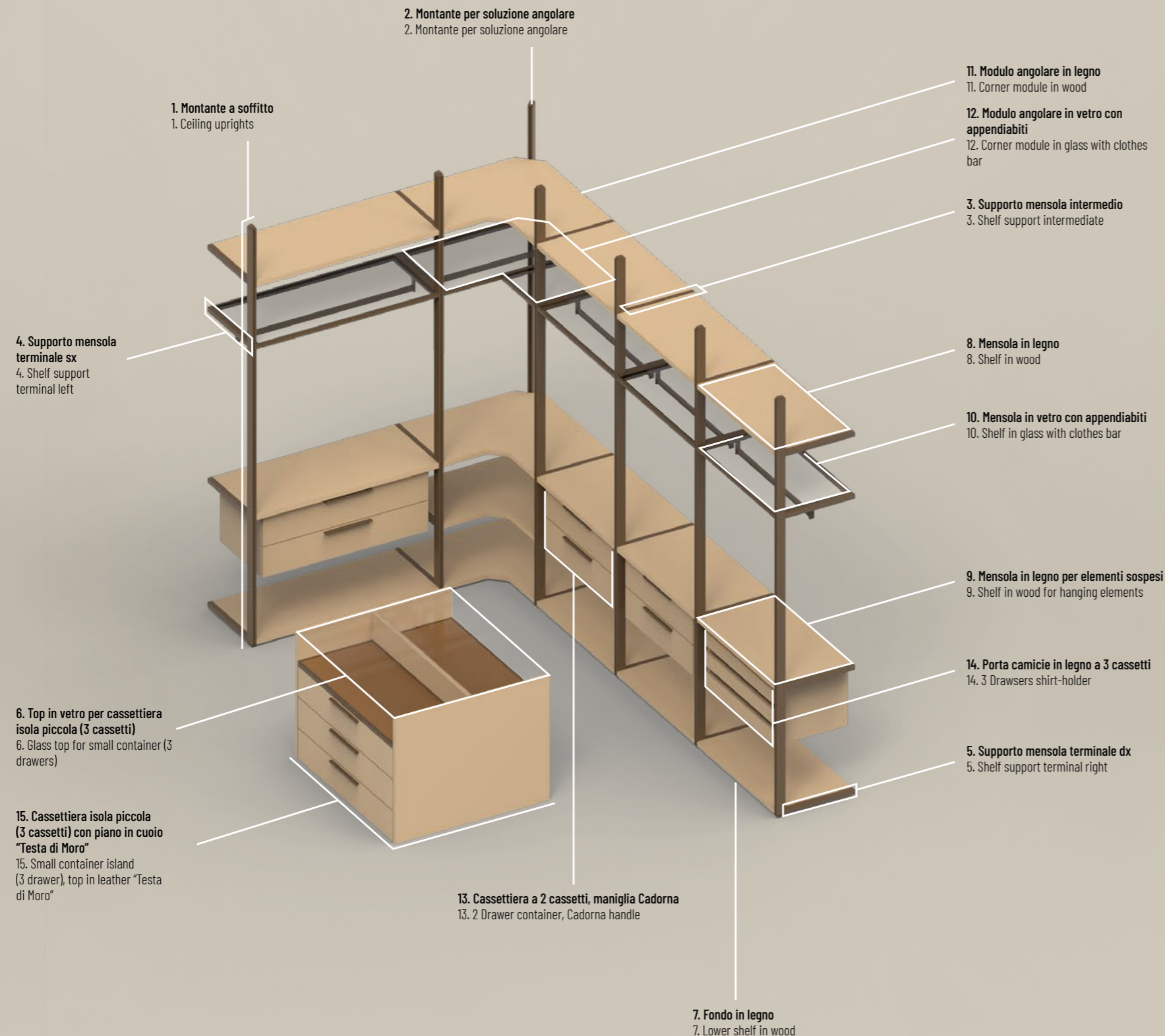



# Cabina armadio Solo nicchia

## Walk-in closet Solo niche

### Montanti frontali / Uprights on front

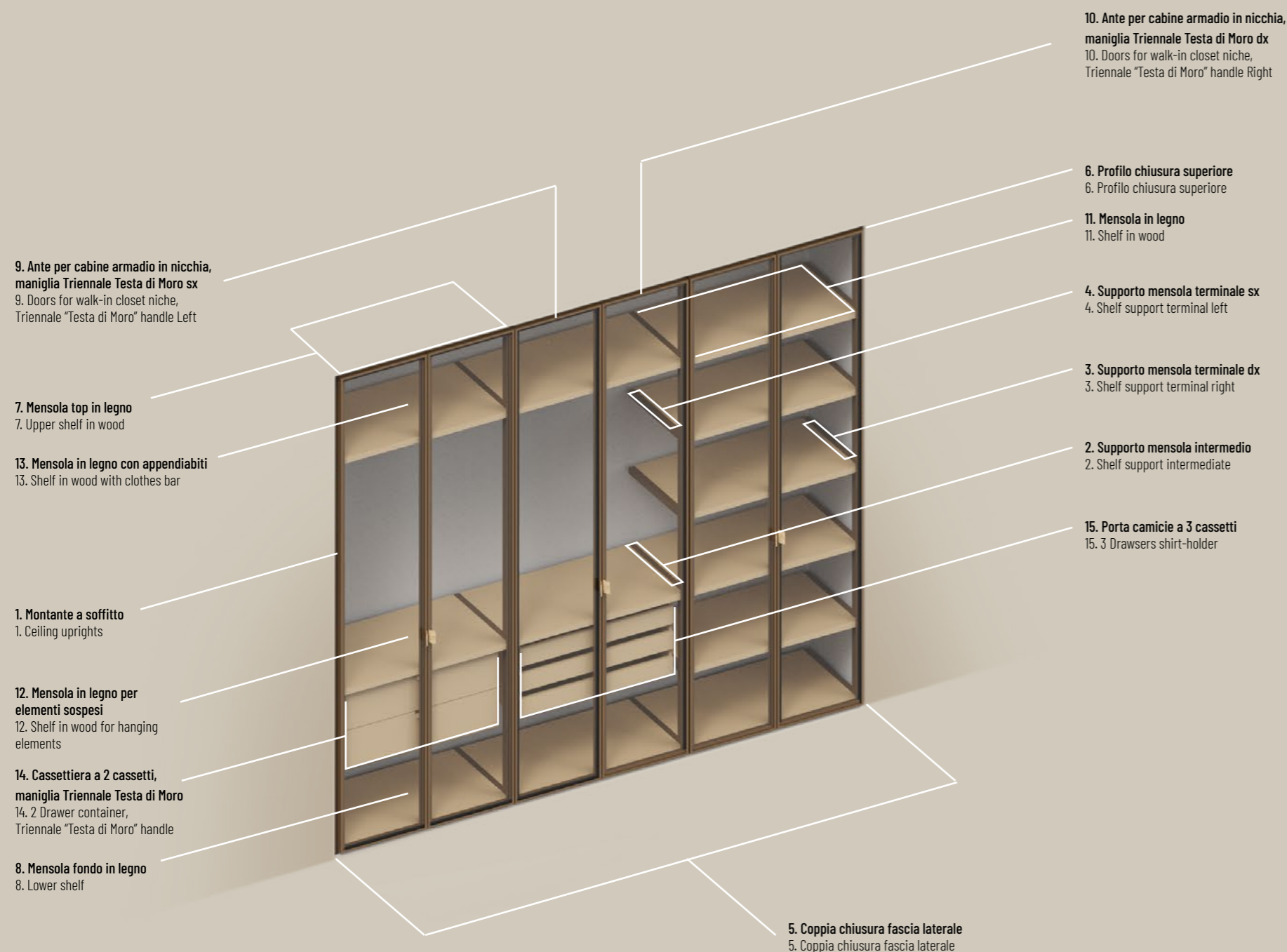

La cabina armadio in nicchia è la soluzione a montanti a soffitto che viene installata all'interno di un vano architettonico. Questo tipo di soluzione consente la possibilità di montare delle ante a battente direttamente sulla struttura.

The niche walk-in closet solution has ceiling uprights that are installed inside an architectural opening. This type of solution makes it possible to fit hinged doors on the structure itself.

### Componenti / Components

#### STRUTTURA / FRAME

- 1. Montante a soffitto**  
1. Ceiling uprights
- 2. Supporto mensola intermedio**  
2. Shelf support intermediate
- 3. Supporto mensola terminale dx**  
3. Shelf support terminal right
- 4. Supporto mensola terminale sx**  
4. Shelf support terminal left
- 5. Coppia chiusura fascia laterale**  
5. coppia chiusura fascia laterale
- 6. Profilo chiusura superiore**  
6. Profilo chiusura superiore

#### TOP / TOP

- 7. Mensola top in legno**  
7. Upper shelf in wood

#### FONDO / BOTTOM

- 8. Mensola fondo in legno**  
8. Lower shelf in wood

#### ANTE / DOORS

- 9. Ante per cabine armadio in nicchia, maniglia Triennale Testa di Moro sx**  
9. Doors for walk-in closet niche, Triennale "Testa di Moro" handle Left
- 10. Ante per cabine armadio in nicchia, maniglia Triennale Testa di Moro dx**  
10. Doors for walk-in closet niche, Triennale "Testa di Moro" handle Right

#### ELEMENTI / ELEMENTS

- 11. Mensola in legno**  
11. Shelf in wood
- 12. Mensola in legno per elementi sospesi**  
12. Shelf in wood for hanging elements
- 13. Mensola in legno con appendiabiti**  
13. Shelf in wood with clothes bar
- 14. Cassettiera a 2 cassetti, maniglia Triennale Testa di Moro**  
14. 2 Drawer container, Cadorna handle, Triennale "Testa di Moro" handle
- 15. Porta camicie a 3 cassetti**  
15. 3 Drawers shirt-holder

# Cabina armadio Solo freestanding

## Walk-in closet Solo freestanding

### Montanti frontali e sul fondo / Uprights on front and on base

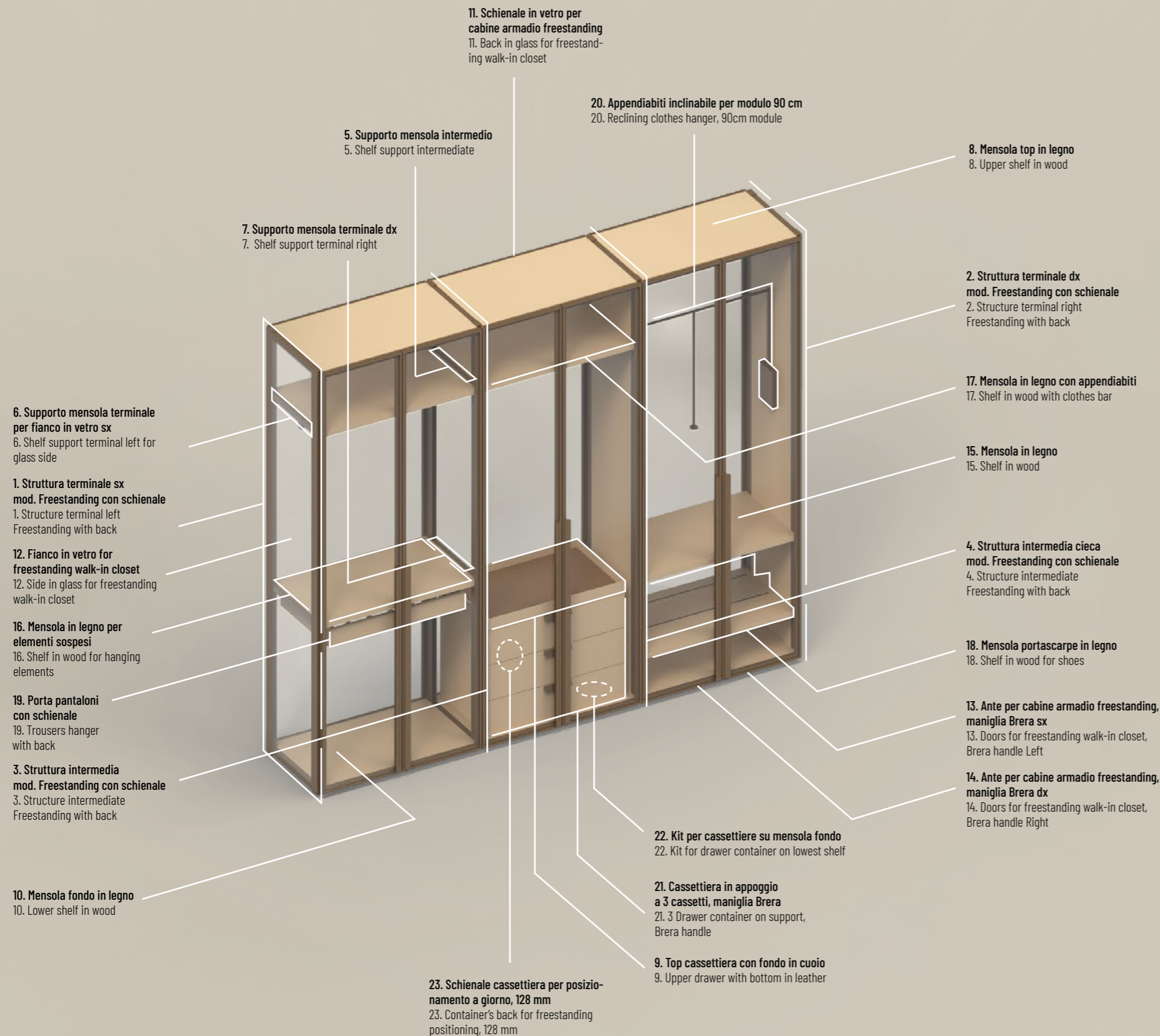

La soluzione ideale quando si desidera utilizzare la cabina armadio come un complemento d'arredo disponendola al centro di una stanza. Configurabile con spalle laterali, schienali e ante, grazie ad una estrema configurabilità e personalizzazione, si presta per interpretare le richieste più impegnative.

This solution is ideal when the walk-in closet is to be used as a furnishing item, putting it in the centre of a room. It is configurable with sides, back panels and doors, and as it is highly configurable and personalisable, it is ideal for applying to the most demanding requirements.

## Componenti / Components

### STRUTTURA / FRAME

- Struttura terminale sx mod. Freestanding con schienale**  
1. Shelf support terminal left for glass side
- Struttura terminale sx mod. Freestanding con schienale**  
2. Structure terminal right Freestanding with back
- Struttura intermedia mod. Freestanding con schienale**  
3. Structure intermediate Freestanding with back
- Struttura intermedia cieca mod. Freestanding con schienale a dx**  
4. Structure intermediate Freestanding with back
- Supporto mensola intermedio**  
5. Shelf support intermediate
- Supporto mensola terminale per fianco in vetro dx**  
6. Shelf support terminal left for glass side
- Supporto mensola terminale dx**  
7. Shelf support terminal right

### TOP / TOP

- Mensola top in legno**  
8. Upper shelf in wood
- Top cassettiere con fondo in cuoio**  
9. Top cassettiere con fondo in cuoio

### FONDO / BOTTOM

- Mensola fondo in legno**  
10. Lower shelf in wood

### SCHIENALI / BACK

- Schienale in vetro per cabine armadio freestanding**  
11. Back in glass for freestanding walk-in closet

### FIANCHI / PARTITIONS

- Fianco in vetro per freestanding walk-in closet**  
12. Side in glass for freestanding walk-in closet

### ANTE / ANTE

- Ante per cabine armadio freestanding, maniglia Brera sx**  
13. Doors for freestanding walk-in closet, Brera handle Left
- Ante per cabine armadio freestanding, maniglia Brera dx**  
14. Doors for freestanding walk-in closet, Brera handle Right

### ELEMENTI / ELEMENTS

- Mensola in legno**  
15. Shelf in wood
- Mensola in legno per elementi sospesi**  
16. Shelf in wood for hanging elements
- Mensola in legno con appendiabiti**  
17. Shelf in wood with clothes bar
- Mensola portascarpe in legno**  
18. Shelf in wood for shoes
- Porta pantaloni con schienale**  
19. Trousers hanger with back
- Appendiabiti inclinabile per modulo 90 cm**  
20. Reclining clothes hanger, 90cm module
- Cassettiere in appoggio a 3 cassetti, maniglia Brera**  
21. 3 Drawer container on support, Brera handle

### ACCESSORI / ACCESSORIES

- Kit per cassettiere su mensola fondo**  
22. Kit for drawer container on lowest shelf
- Schienale cassettiere per posizionamento a giorno, 128 mm**  
23. Container's back for freestanding positioning, 128 mm

# Struttura cabina armadio

## Walk-in closet structure

### Montanti a parete / Wall Uprights

#### MONTANTI A PARETE / WALL UPRIGHTS

Altezza Height	Prezzo Price	SOLO   Montante frontale SOLO   Upright on front		RI-VISTA   Montante sul fondo RI-VISTA   Upright on base
		P300 [1]	P500 [2]	[3]
H2200	€ 212	S000400	S000100	S001100
H2400	€ 224	S000500	S000200	S001200
H2600	€ 237	S000600	S000300	S001300

#### MONTANTI PER SOLUZIONI ANGOLARI A PARETE / UPRIGHTS FOR CORNER SOLUTIONS ON WALL

Altezza Height	Prezzo Price	SOLO   Montante per angolo SOLO   Upright for corner
		[4]
H2200	€ 182	S009100
H2400	€ 188	S009200
H2600	€ 206	S009300

#### MONTANTI A PARETE PREDISPOSTI PER SCHIENALE / WALL UPRIGHTS DESIGNED FOR BACK

Altezza Height	Prezzo Price	RI-VISTA   Montante sul fondo predisposto per schienale RI-VISTA   Upright on front designed for back panel			
		Intermedio Intermediate	A destra On Right	A sinistra On left	Angolare Corner
2200	€ 212	S006100	S006600	S007100	S008100
2400	€ 224	S006200	S006700	S007200	S008200
2600	€ 237	S006300	S006800	S007300	S008300

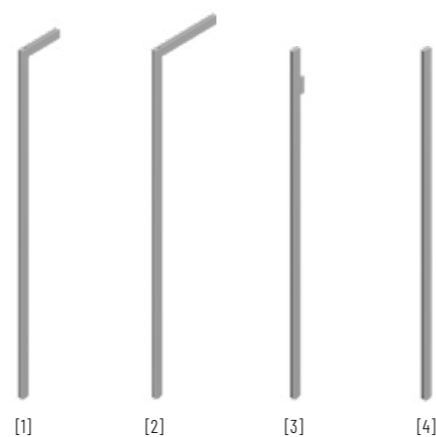

### Montanti a soffitto / Ceiling upright

#### MONTANTI A SOFFITTO / CEILING UPRIGHTS

Altezza Height	Prezzo Price	SOLO e RI-VISTA   montante SOLO e RI-VISTA   upright
H1000 - H2300	€ 182	S002100
H2300 - H2500	€ 194	S002200
H2500 - H2700	€ 206	S002300
H2700 - H3000	€ 218	S002400
H3000 - H3200	€ 231	S002500

#### MONTANTI PER SOLUZIONI ANGOLARI A SOFFITTO / UPRIGHTS FOR CORNER SOLUTIONS ON CEILING

Altezza Height	Prezzo Price	SOLO   Montante per angolo SOLO   Upright for corner
H1000 - H2400	€ 188	S010100
H2400 - H2600	€ 206	S010200
H2600 - H3000	€ 218	S010300
H3000 - H3200	€ 231	S010400

#### MONTANTI A SOFFITTO PREDISPOSTI PER SCHIENALE / CEILING UPRIGHTS DESIGNED FOR BACK PANEL

Altezza Height	Prezzo Price	RI-VISTA   Montante predisposto per schienale RI-VISTA   Upright designed for back			
		Intermedio Intermediate	A destra On Right	A sinistra On left	Angolare Corner
H1000 - H2300	€ 206	S003100	S003600	S004100	S005100
H2300 - H2500	€ 212	S003200	S003700	S004200	S005200
H2500 - H2700	€ 218	S003300	S003800	S004300	S005300
H2700 - H3000	€ 224	S003400	S003900	S004400	S005400
H3000 - H3200	€ 231	S003500	S004000	S004500	S005500



### Struttura freestanding / Freestanding structure

#### STRUTTURA FREESTANDING / FREESTANDING STRUCTURE

Altezza Height	Posizionamento Positioning	Prezzo Price	SOLO   Struttura Freestanding con predisposizione schienale SOLO   Freestanding structure designed for back			
			No schienale No back	Intermedio Intermediate	A destra On Right	A sinistra On left
H2200	Terminale / Terminal	€ 449	S014400	–	S015400	S015700
	Intermedio / Intermediate	€ 449	S014100	S015100	S016400	S016100
H2400	Terminale / Terminal	€ 467	S014500	–	S015500	S015800
	Intermedio / Intermediate	€ 467	S014200	S015200	S016500	S016200
H2600	Terminale / Terminal	€ 491	S014600	–	S015600	S015900
	Intermedio / Intermediate	€ 491	S014300	S015300	S016600	S016300

Per chiusura della composizione tramite fianco in vetro, utilizzare queste strutture insieme ai fianchi in vetro a p.329.  
To close the composition with a side in glass, use these structures in combination with the side in glass on p.329.

#### STRUTTURA FREESTANDING CIECA / FREESTANDING ENCLOSED STRUCTURE

Altezza Height	Posizionamento Positioning	Legno / Wood				SOLO   Struttura Freestanding cieca predisposto per schienale SOLO   Freestanding enclosed structure designed for back			
		Cat. 1	Cat. 2	Cat. 3	Cat. 4	No schienale No back	Intermedio Intermediate	A destra On Right	A sinistra On left
H2200	Terminale / Terminal	€ 679	€ 716	€ 837	€ 922	S014410	–	S015410	S015710
	Intermedio / Intermediate	€ 679	€ 716	€ 837	€ 922	S014110	S015110	S016410	S016110
H2400	Terminale / Terminal	€ 722	€ 758	€ 880	€ 977	S014510	–	S015510	S015810
	Intermedio / Intermediate	€ 722	€ 758	€ 880	€ 977	S014210	S015210	S016510	S016210
H2600	Terminale / Terminal	€ 770	€ 807	€ 928	€ 1.025	S014610	–	S015610	S015910
	Intermedio / Intermediate	€ 770	€ 807	€ 928	€ 1.025	S014310	S015310	S016610	S016310

La struttura freestanding cieca presenta dei passi fissi per le mensole: il primo posizionato a 1300mm da terra, gli altri a 100mm tra di loro.  
The freestanding enclosed structure has fixed steps for the shelves: the first positioned 1300mm from the floor, the others 100mm between them.

### Telaio scorrevole / Sliding frame

#### TELAIO SCORREVOLE / SLIDING FRAME

Altezza Height	Larghezza modulo Module width	Prezzo Price	RI-VISTA   Telaio scorrevole RI-VISTA   Sliding frame
H1000 - H2300	L600	€ 910	S075100
	L900	€ 1.011	S075400
	L1200	€ 1.128	S075700
H2300 - H3000	L600	€ 934	S075200
	L900	€ 1.037	S075500
	L1200	€ 1.159	S075800
H3000 - H3200	L600	€ 959	S075300
	L900	€ 1.064	S075600
	L1200	€ 1.201	S075900

#### TELAIO SCORREVOLE CON SCHIENALE / SLIDING FRAME WITH BACK

Altezza Height	Larghezza modulo Module width	Vetro / Glass					RI-VISTA   Telaio scorrevole RI-VISTA   Sliding frame
		Cat. A	Cat. B	Cat. C	Cat. D	Cat. E	
H1000 - H2300	L600	€ 1.201	€ 1.323	€ 1.614	€ 1.844	€ 1.844	S076100
	L900	€ 1.335	€ 1.468	€ 1.790	€ 2.045	€ 2.045	S076400
	L1200	€ 1.535	€ 1.687	€ 2.057	€ 2.354	€ 2.354	S076700
H2300 - H3000	L600	€ 1.274	€ 1.395	€ 1.711	€ 1.954	€ 1.954	S076200
	L900	€ 1.414	€ 1.547	€ 1.899	€ 2.172	€ 2.172	S076500
	L1200	€ 1.626	€ 1.784	€ 2.184	€ 2.493	€ 2.493	S076800
H3000 - H3200	L600	€ 1.310	€ 1.420	€ 1.772	€ 2.026	€ 2.026	S076300
	L900	€ 1.456	€ 1.577	€ 1.966	€ 2.251	€ 2.251	S076600
	L1200	€ 1.674	€ 1.814	€ 2.263	€ 2.584	€ 2.584	S076900

Il telaio scorrevole presenta dei passi fissi per le mensole: il primo posizionato a 217mm dal basso, gli altri a 300mm tra di loro.  
The sliding frame has fixed steps for the shelves: the first positioned 217mm from the bottom, the others 300mm between them.



# Struttura cabina armadio

## Walk-in closet structure

### Supporti mensola / Shelf support

#### SUPPORTO MENSOLA PER MONTANTI / SHELF SUPPORT FOR UPRIGHT

Posizionamento Positioning	Prezzo Price	SOLO e RI-VISTA   supporto mensola SOLO   shelf support	
		Profondità P300 Depth P300	Profondità P500 Depth P500
Intermedio / Intermediate [2]	€ 42	S011100	S012100
Terminale dx / Terminal R [3]	€ 42	S011200	S012200
Terminale sx / Terminal L [1]	€ 42	S011300	S012300

I supporti mensola sono condivisi tra le soluzioni Solo (con montanti frontali) e le soluzioni Rivista (con montanti sul fondo). Le diciture "dx" e "sx" si riferiscono a quando il supporto mensola è montato su una soluzione Solo (con montanti frontali), nel caso di soluzioni Rivista (con montanti sul fondo) invertire "dx" e "sx". Shelf supports are shared between Solo solutions (with uprights on front) and Rivista solutions (with uprights on base). The words "Right" and "Left" refer to when the shelf support is mounted on a Solo solution (with uprights on front), in the case of Rivista solutions (with uprights on base) reverse "Right" and "Left".

#### SUPPORTO MENSOLA PER STRUTTURA FREESTANDING / SHELF SUPPORT FOR FREESTANDING STRUCTURE

Posizionamento Positioning	Prezzo Price	SOLO   supporto mensola per struttura Freestanding SOLO   shelf support for Freestanding structure	
		No spalla No side	Predisposizione spalla in vetro Designed for glass side
Intermedio / Intermediate [2]	€ 49	S013100	-
Terminale dx / Terminal R [3]	€ 49	S013200	S013300
Terminale sx / Terminal L [1]	€ 49	S013400	S013500



#### SUPPORTO MENSOLA PER TELAIO SCORREVOLE / SHELF SUPPORT FOR SLIDING FRAME

Posizionamento Positioning	Prezzo Price	RI-VISTA   supporto mensola per telaio scorrevole RI-VISTA   shelf support for Sliding frame	
		Profondità P300 Depth P300	Profondità P500 Depth P500
Terminale dx / Terminal R [5]	€ 35	S077100	S077200
Terminale sx / Terminal L [4]	€ 35	S077100	S077200

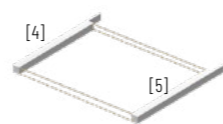

### Sistema binario / Rail system

#### BINARI / BINARI

Tipologia binario Rail type	Prezzo Price	RI-VISTA   Binario RI-VISTA   Rail
Binario Uno a soffitto Ceiling Uno rail	€/ml 79	S078100
Binario Uno a pavimento Floor Uno rail	€/ml 53	S078200
Binario Uno a pavimento incassato Built-in floor Uno rail	€/ml 48	S078300
Binario Uno a pavimento incassato con inserto in alluminio / Built-in floor Uno rail with aluminium insert	€/ml 74	S078400

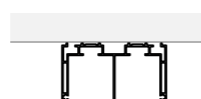

Binario a soffitto  
Ceiling rail

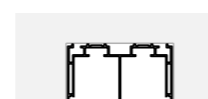

Binario a soffitto (incassato)  
Ceiling rail (built-in)



Binario a pavimento  
Built-in floor rail

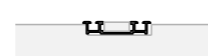

Binario a pavimento incassato  
Built-in floor rail



Binario a pavimento incassato con inserto alluminio  
Built-in floor rail with aluminium insert

# Elementi cabina armadio

## Walk-in closet elements

### Mensole top e fondo / Upper and lower shelves

#### MENSOLA TOP (P500) / UPPER SHELF (P500)

L modulo L module	Legno / Wood				No led* No led*	Foro sensore accensione Led* Led ignition sensor hole*
	Nobilitato Nobilitato Cat. 1	Nobilitato Nobilitato Cat. 2	Laccato Lacquered Cat. 3	Essenza legno Wood essence Cat. 4		
L230-L449	€ 158	€ 176	€ 194	€ 237	S01921X	S01926X
L450	€ 115	€ 133	€ 152	€ 194	S01911X	S01916X
L451-L599	€ 164	€ 182	€ 200	€ 255	S01941X	S01946X
L600	€ 121	€ 140	€ 158	€ 212	S01931X	S01936X
L601-L899	€ 170	€ 194	€ 243	€ 315	S01961X	S01966X
L900	€ 127	€ 152	€ 200	€ 273	S01951X	S01956X
L901-L1199	€ 182	€ 206	€ 285	€ 370	S01981X	S01986X
L1200	€ 140	€ 164	€ 243	€ 328	S01971X	S01976X

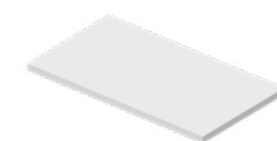

Mensola top  
Upper shelf

#### MODULO TOP ANGOLARE (P500) / UPPER CORNER MODULE (P500)

L modulo L module	Legno / Wood				No led* No led*
	Cat. 1	Cat. 2	Cat. 3	Cat. 4	
L900	€ 133	€ 182	€ 267	€ 400	S020111



Modulo top angolare  
Upper corner module

#### MENSOLA TOP CON APPENDIABILI (P500) / UPPER SHELF WITH CLOTHES BAR (P500)

L modulo L module	Legno / Wood				No led* No led*	Foro sensore accensione Led* Led ignition sensor hole*
	Cat. 1	Cat. 2	Cat. 3	Cat. 4		
L230-L449	€ 255	€ 267	€ 291	€ 334	S01923X	S01927X
L450	€ 182	€ 194	€ 218	€ 261	S01913X	S01917X
L451-L599	€ 261	€ 273	€ 297	€ 352	S01943X	S01947X
L600	€ 188	€ 200	€ 224	€ 279	S01933X	S01937X
L601-L899	€ 279	€ 297	€ 340	€ 413	S01963X	S01967X
L900	€ 206	€ 224	€ 267	€ 340	S01953X	S01957X
L901-L1199	€ 291	€ 309	€ 382	€ 467	S01983X	S01987X
L1200	€ 218	€ 237	€ 309	€ 394	S01973X	S01977X



Mensola top con appendiabili  
Upper shelf with clothes bar

#### MODULO TOP ANGOLARE CON APPENDIABILI (P500) / UPPER CORNER MODULE WITH CLOTHES BAR (P500)

L modulo L module	Legno / Wood				No led* No led*
	Cat. 1	Cat. 2	Cat. 3	Cat. 4	
L900	€ 212	€ 261	€ 346	€ 479	S020131



Modulo top angolare con appendiabili  
Upper corner module with clothes bar

#### MENSOLA FONDO (P500) / LOWER SHELF (P500)

L modulo L module	Legno / Wood				No led* No led*	Foro sensore accensione Led* Led ignition sensor hole*
	Cat. 1	Cat. 2	Cat. 3	Cat. 4		
L230-L449	€ 158	€ 176	€ 194	€ 237	S01921X	S01926X
L450	€ 115	€ 133	€ 152	€ 194	S01911X	S01916X
L451-L599	€ 164	€ 182	€ 200	€ 255	S01941X	S01946X
L600	€ 121	€ 140	€ 158	€ 212	S01931X	S01936X
L601-L899	€ 170	€ 194	€ 243	€ 315	S01961X	S01966X
L900	€ 127	€ 152	€ 200	€ 273	S01951X	S01956X
L901-L1199	€ 182	€ 206	€ 285	€ 370	S01981X	S01986X
L1200	€ 140	€ 164	€ 243	€ 328	S01971X	S01976X



Mensola fondo  
Lower shelf

#### MODULO FONDO ANGOLARE (P500) / LOWER CORNER MODULE (P500)

L modulo L module	Legno / Wood				No led* No led*
	Cat. 1	Cat. 2	Cat. 3	Cat. 4	
L900	€ 133	€ 182	€ 267	€ 400	S020115



Modulo fondo angolare  
Lower corner module

\*al momento dell'ordine specificare la predisposizione alle ante: No ante (X=1), Anta sinistra (X=2), Anta destra (X=3), Anta doppia (X=4). L'opzione No ante (X=1) è disponibile solo con Mensola top, Mensola top con appendiabili e Mensola fondo senza foro per sensore Led. \* when ordering, specify the predisposition to the doors: No doors (X = 1), Left door (X = 2), Right door (X = 3), Double door (X = 4). The No doors option (X = 1) is available only with Upper shelf, Upper shelf with coat hanger and Lower shelf without hole for Led sensor.

# Elementi cabina armadio

## Walk-in closet elements

### Mensole / Shelves

#### MENSOLA RIDOTTA (P300) / REDUCED SHELF (P300)

L modulo L module	Legno / Wood				Vetro / Glass			Cuoio*/Leather*	Legno Wood	Vetro o Cuoio Glass or Leather
	Nobilitato Cat. 1	Nobilitato Cat. 2	Laccato Cat. 3	Essenza legno Cat. 4	Cat. A	Cat. B	Cat. 5			
L230-L449	€ 109	€ 127	€ 146	€ 182	€ 206	€ 218	€ 267	S018210	S018200	
L450	€ 67	€ 85	€ 103	€ 140	€ 164	€ 176	€ 224	S018110	S018100	
L451-L599	€ 115	€ 133	€ 152	€ 200	€ 221	€ 233	€ 297	S018410	S018400	
L600	€ 73	€ 91	€ 109	€ 158	€ 178	€ 191	€ 255	S018310	S018300	
L601-L899	€ 121	€ 146	€ 200	€ 261	€ 243	€ 258	€ 358	S018610	S018600	
L900	€ 79	€ 103	€ 158	€ 218	€ 200	€ 216	€ 315	S018510	S018500	
L901-L1199	€ 133	€ 158	€ 243	€ 315	€ 261	€ 285	€ 419	S018810	S018800	
L1200	€ 91	€ 115	€ 200	€ 273	€ 218	€ 243	€ 376	S018710	S018700	

#### MENSOLA (P500) / SHELF (P500)

L modulo L module	Legno / Wood				Vetro / Glass			Cuoio*/Leather*	Legno Wood	Vetro o Cuoio Glass or Leather
	Cat. 1	Cat. 2	Cat. 3	Cat. 4	Cat. A	Cat. B	Cat. 5			
L230-L449	€ 115	€ 133	€ 152	€ 194	€ 224	€ 237	€ 279	S019210	S019200	
L450	€ 73	€ 91	€ 109	€ 152	€ 182	€ 194	€ 237	S019110	S019100	
L451-L599	€ 121	€ 140	€ 158	€ 212	€ 243	€ 255	€ 309	S019410	S019400	
L600	€ 79	€ 97	€ 115	€ 170	€ 200	€ 212	€ 267	S019310	S019300	
L601-L899	€ 127	€ 152	€ 200	€ 273	€ 267	€ 285	€ 370	S019610	S019600	
L900	€ 85	€ 109	€ 158	€ 231	€ 224	€ 243	€ 328	S019510	S019500	
L901-L1199	€ 140	€ 164	€ 243	€ 328	€ 291	€ 334	€ 431	S019810	S019800	
L1200	€ 97	€ 121	€ 200	€ 285	€ 249	€ 291	€ 388	S019710	S019700	

#### MODULO ANGOLARE (P500) / CORNER MODULE (P500)

L modulo L module	Legno / Wood				Vetro / Glass			Cuoio*/Leather*	Legno Wood	Vetro o Cuoio Glass or Leather
	Cat. 1	Cat. 2	Cat. 3	Cat. 4	Cat. A	Cat. B	Cat. 5			
L900	€ 133	€ 182	€ 267	€ 400	€ 382	€ 413	€ 546	S020110	S020100	

#### MENSOLA APPENDIABILI (P500) / SHELF WITH CLOTHES BAR (P500)

L modulo L module	Legno / Wood				Vetro / Glass			Cuoio*/Leather*	Legno Wood	Vetro o Cuoio Glass or Leather
	Cat. 1	Cat. 2	Cat. 3	Cat. 4	Cat. A	Cat. B	Cat. 5			
L230-L449	€ 212	€ 224	€ 249	€ 291	€ 322	€ 334	€ 376	S019230	S019220	
L450	€ 140	€ 152	€ 176	€ 218	€ 249	€ 261	€ 303	S019130	S019120	
L451-L599	€ 218	€ 231	€ 255	€ 309	€ 340	€ 352	€ 406	S019430	S019420	
L600	€ 146	€ 158	€ 182	€ 237	€ 267	€ 279	€ 334	S019330	S019320	
L601-L899	€ 237	€ 255	€ 297	€ 370	€ 364	€ 382	€ 467	S019630	S019620	
L900	€ 164	€ 182	€ 224	€ 297	€ 291	€ 309	€ 394	S019530	S019520	
L901-L1199	€ 249	€ 267	€ 340	€ 425	€ 388	€ 431	€ 528	S019830	S019820	
L1200	€ 176	€ 194	€ 267	€ 352	€ 315	€ 358	€ 455	S019730	S019720	

#### MODULO APPENDIABILI ANGOLARE (P500) / CORNER MODULE WITH CLOTHES BAR (P500)

L modulo L module	Legno / Wood				Vetro / Glass			Cuoio*/Leather*	Legno Wood	Vetro o Cuoio Glass or Leather
	Cat. 1	Cat. 2	Cat. 3	Cat. 4	Cat. A	Cat. B	Cat. 5			
L900	€ 212	€ 261	€ 346	€ 479	€ 461	€ 491	€ 625	S020130	S020120	

#### MENSOLA PORTASCARPE (P500) / SHELF FOR SHOES (P500)

L modulo L module	Legno / Wood				Vetro / Glass			Cuoio*/Leather*	Legno Wood	Vetro o Cuoio Glass or Leather
	Cat. 1	Cat. 2	Cat. 3	Cat. 4	Cat. A	Cat. B	Cat. 5			
L230-L899	€ 297	€ 315	€ 358	€ 425	€ 540	€ 558	€ 704	S019650	S019640	
L900	€ 224	€ 243	€ 285	€ 352	€ 467	€ 485	€ 631	S019550	S019540	
L901-L1199	€ 309	€ 328	€ 394	€ 473	€ 582	€ 625	€ 789	S019850	S019840	
L1200	€ 237	€ 255	€ 322	€ 400	€ 510	€ 552	€ 716	S019750	S019740	

\*cuoio rigenerato / regenerated leather



Mensola ridotta in legno  
Reduced shelf in wood



Mensola ridotta in vetro  
Reduced shelf in glass

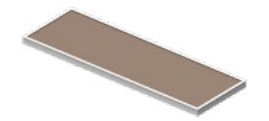

Mensola ridotta in cuoio  
Reduced shelf in leather



Mensola in legno  
Shelf in wood



Mensola in vetro  
Shelf in glass



Mensola in cuoio  
Shelf in leather



Modulo angolare in legno  
Corner module in wood

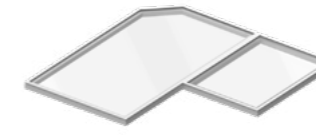

Modulo angolare in vetro  
Corner module in glass

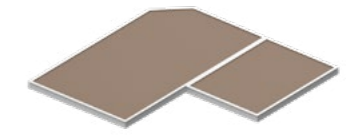

Modulo angolare in cuoio  
Corner leather in wood



Mensola in legno con appendiabiti  
Shelf in wood with clothes bar

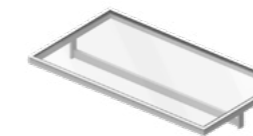

Mensola in vetro con appendiabiti  
Shelf in glass with clothes bar



Mensola in cuoio con appendiabiti  
Shelf in leather with clothes bar



Modulo angolare in legno con appendiabiti  
Corner module in wood with clothes bar

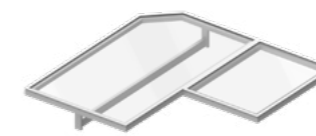

Modulo angolare in vetro con appendiabiti  
Corner module in glass with clothes bar

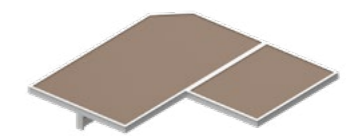

Modulo angolare in cuoio con appendiabiti  
Corner module in leather with clothes bar



Mensola portascarpe in legno  
Shelf in wood for shoes

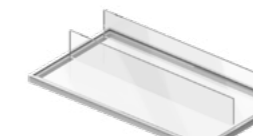

Mensola portascarpe in vetro  
Shelf in glass for shoes

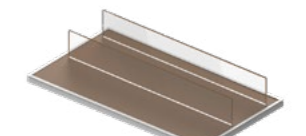

Mensola portascarpe in cuoio  
Shelf in leather for shoes

# Elementi cabina armadio

## Walk-in closet elements

### Cassettiere sospese / Hanging drawer

#### 1 MENSOLA PER ELEMENTI SOSPESI / SHELF FOR HANGING ELEMENTS

Tipologia elemento Element typology	L modulo L module	Legno / Wood				Cuoio*/Leather*		Legno Wood	Cuoio Leather
		Nobilitato Nobilitato Cat. 1	Nobilitato Nobilitato Cat. 2	Laccato Lacquered Cat. 3	Essenza legno Wood essence Cat. 4	Cat. 5			
Mensola per elementi sospesi Shelf for hanging elements	L560-L599	€ 121	€ 140	€ 158	€ 212	€ 309	S019419	S019489	
	L600	€ 79	€ 97	€ 115	€ 170	€ 267	S019319	S019389	
	L601-899	€ 127	€ 152	€ 200	€ 273	€ 370	S019619	S019689	
	L900	€ 85	€ 109	€ 158	€ 231	€ 328	S019519	S019589	
	L901-L1199	€ 97	€ 121	€ 200	€ 285	€ 431	S019819	S019889	
	L1200	€ 140	€ 164	€ 243	€ 328	€ 388	S019719	S019789	

\*cuoio rigenerato / regenerated leather

#### 2 CASSETTIERA SOSPESA / HANGING DRAWER

Tipologia elemento Element typology	L modulo L module	Legno / Wood				Cuoio / Leather		Legno* Wood*	Cuoio** Leather**
		Cat. 1	Cat. 2	Cat. 3	Cat. 4	Cat. 5			
Cassettiera 1 cassetto 1 drawer container	L560-L858	€ 309	€ 413	€ 491	€ 655	€ 764	S05011X	S05018X	
	L860-L1158	€ 340	€ 473	€ 497	€ 679	€ 752	S05021X	S05028X	
	L1200	€ 364	€ 534	€ 540	€ 722	€ 922	S05031X	S05038X	
Cassettiera 2 cassetti 2 drawer container	L560-L858	€ 419	€ 534	€ 601	€ 764	€ 886	S05041X	S05048X	
	L860-L1158	€ 449	€ 595	€ 607	€ 789	€ 874	S05051X	S05058X	
	L1200	€ 473	€ 655	€ 649	€ 831	€ 1.044	S05061X	S05068X	
Cassettiera 3 cassetti 3 drawer container	L860-L1158	€ 540	€ 655	€ 795	€ 983	€ 1.165	S05071X	S05078X	
	L1200	€ 570	€ 728	€ 789	€ 1.019	€ 1.189	S05081X	S05088X	

\*al momento dell'ordine specificare le maniglie: Triennale Fango (X=3), Triennale Testa di Moro (X=C), Brera (X=6), Cadorna (X=9)

\*\* when ordering, specify the handles: Triennale Fango (X = 3), Triennale Testa di Moro (X = C), Brera (X = 6), Cadorna (X = 9)

\*al momento dell'ordine specificare le maniglie: Triennale Fango (X=3), Triennale Testa di Moro (X=C)

\*\* when ordering, specify the handles: Triennale Fango (X = 3), Triennale Testa di Moro (X = C)

#### 3 SCHIENALE PER ELEMENTO PER POSIZIONAMENTO A GIORNO / BACK ELEMENT OPEN

Elementi compatibili Compatible elements	L modulo L module	Legno / Wood				Cuoio / Leather		Legno Wood	Cuoio Leather
		Cat. 1	Cat. 2	Cat. 3	Cat. 4	Cat. 5			
Cassettiera 1 cassetto 1 drawer container	L560-L858	€ 24	€ 32	€ 49	€ 91	€ 49	S058310	S058380	
	L860-L1158	€ 30	€ 38	€ 73	€ 121	€ 73	S058410	S058480	
	L1200	€ 36	€ 44	€ 97	€ 152	€ 97	S058510	S058580	
Cassettiera 2 cassetti 2 drawer container	L560-L858	€ 30	€ 38	€ 55	€ 97	€ 55	S058810	S058880	
	L860-L1158	€ 36	€ 44	€ 79	€ 127	€ 79	S058910	S058980	
	L1200	€ 42	€ 50	€ 103	€ 158	€ 103	S059010	S059080	
Cassettiera 3 cassetti 3 drawer container	L860-L1158	€ 36	€ 44	€ 61	€ 103	€ 61	S059110	S059180	
	L1200	€ 42	€ 50	€ 85	€ 133	€ 85	S059210	S059280	

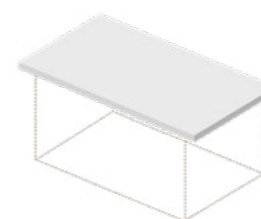

Mensola in legno per elementi sospesi  
Shelf in wood for hanging elements

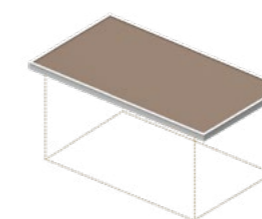

Mensola in cuoio per elementi sospesi  
Shelf in leather for hanging elements

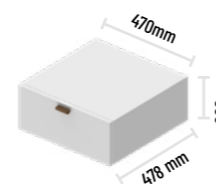

Cassettiera 1 cassetto (per modulo L560-L858)  
1 Drawer container (for module L560-L858)

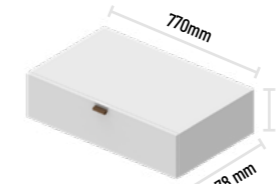

Cassettiera 1 cassetto (per modulo L860-L1158)  
1 Drawer container (for module L860-L1158)

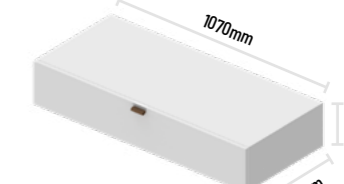

Cassettiera 1 cassetto (per modulo L1200)  
1 Drawer container (for module L1200)

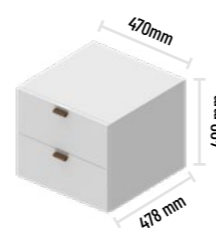

Cassettiera 2 cassetti (per modulo L560-L858)  
2 Drawer container (for module L560-L858)

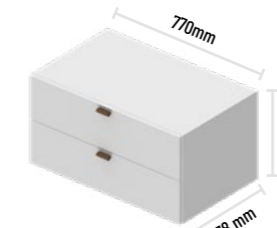

Cassettiera 2 cassetti (per modulo L860-L1158)  
2 Drawer container (for module L860-L1158)

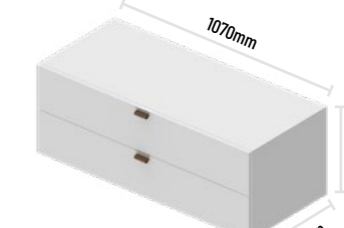

Cassettiera 2 cassetti (per modulo L1200)  
2 Drawer container (for module L1200)

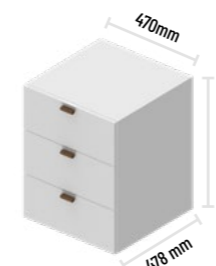

Cassettiera 3 cassetti (per modulo L560-L858)  
3 Drawer container (for module L560-L858)

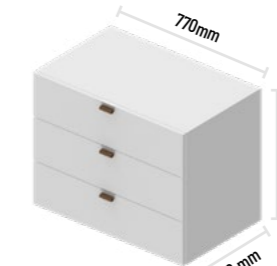

Cassettiera 3 cassetti (per modulo L860-L1158)  
3 Drawer container (for module L860-L1158)

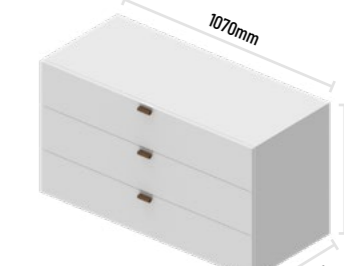

Cassettiera 3 cassetti (per modulo L1200)  
3 Drawer container (for module L1200)



Triennale



Brera



Cadorna

# Elementi cabina armadio

## Walk-in closet elements

### Altri elementi sospesi / Other hanging elements

#### 1 MENSOLA PER ELEMENTI SOSPESI / SHELF FOR HANGING ELEMENTS

Tipologia elemento Element typology	L modulo L module	Legno / Wood				Cuoio*/Leather*		Legno Wood	Cuoio Leather
		Nobilitato Nobilitato Cat. 1	Nobilitato Nobilitato Cat. 2	Laccato Lacquered Cat. 3	Essenza legno Wood essence Cat. 4	Cat. 5			
Mensola per elementi sospesi Shelf for hanging elements	L560-L599	€ 121	€ 140	€ 158	€ 212	€ 309	S019419	S019489	
	L600	€ 79	€ 97	€ 115	€ 170	€ 267	S019319	S019389	
	L601-899	€ 127	€ 152	€ 200	€ 273	€ 370	S019619	S019689	
	L900	€ 85	€ 109	€ 158	€ 231	€ 328	S019519	S019589	
	L901-L1199	€ 97	€ 121	€ 200	€ 285	€ 431	S019819	S019889	
	L1200	€ 140	€ 164	€ 243	€ 328	€ 388	S019719	S019789	

\*cuoio rigenerato / regenerated leather

#### 2 ELEMENTO SOSPESO / HANGING ELEMENT

Tipologia elemento Element typology	L modulo L module	Legno / Wood				Cuoio / Leather		Legno* Wood*	Cuoio** Leather**
		Cat. 1	Cat. 2	Cat. 3	Cat. 4	Cat. 5			
Portacamicie 3 cassetti 3 drawers shirt-holder	L560-L858	€ 328	€ 425	€ 510	€ 595	€ 558	S053110	S053180	
	L860-L1158	€ 364	€ 461	€ 540	€ 649	€ 558	S053210	S053280	
	L1200	€ 328	€ 425	€ 631	€ 595	€ 667	S052310	S052380	
Portacravatte Ties hanger	L860-L1158	€ 364	€ 461	€ 673	€ 625	€ 704	S052410	S052480	
	L1200	€ 631	€ 667	€ 861	€ 849	€ 1.080	S052110	S052180	
Portapantaloni Trousers hanger	L860-L1158	€ 679	€ 716	€ 1.001	€ 892	€ 1.189	S052210	S052280	
	L1200	€ 479	€ 534	€ 783	€ 898	€ 1.007	S051110	S051180	
Portapantaloni e cravatte Trousers and ties hanger	L860-L1158	€ 510	€ 582	€ 777	€ 922	€ 995	S051210	S051280	
	L1200	€ 534	€ 643	€ 868	€ 953	€ 1.104	S051310	S051380	
Mobile a giorno Open base unit	L860-L1158	€ 388	€ 485	€ 801	€ 959	€ 934	S054110	S054180	
	L1200	€ 425	€ 595	€ 831	€ 1.292	€ 1.250	S054210	S054280	

#### 3 SCHIENALE PER ELEMENTO PER POSIZIONAMENTO A GIORNO / BACK ELEMENT OPEN

Elementi compatibili Compatible elements	L modulo L module	Legno / Wood				Cuoio / Leather		Legno Wood	Cuoio Leather
		Cat. 1	Cat. 2	Cat. 3	Cat. 4	Cat. 5			
Portacamicie / Shirt-holder Mobile a giorno / Open base unit	L560-L858	€ 30	€ 38	€ 55	€ 97	€ 55	S058810	S058880	
	L860-L1158	€ 36	€ 44	€ 79	€ 127	€ 79	S058910	S058980	
	L1200	€ 42	€ 50	€ 103	€ 158	€ 103	S059010	S059080	
Portacravatte / Ties hanger Portapantaloni / Trousers hanger	L860-L1158	€ 36	€ 44	€ 79	€ 127	€ 79	S058110	S058180	
	L1200	€ 42	€ 50	€ 103	€ 158	€ 103	S058210	S058280	
Portapantaloni e cravatte Trousers and ties hanger	L860-L1158	€ 30	€ 38	€ 73	€ 121	€ 73	S058610	S058680	
	L1200	€ 36	€ 44	€ 97	€ 152	€ 97	S058710	S058780	

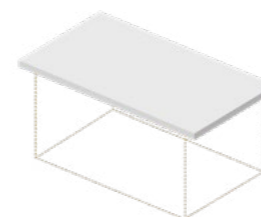

Mensola in legno per elementi sospesi  
Shelf in wood for hanging elements

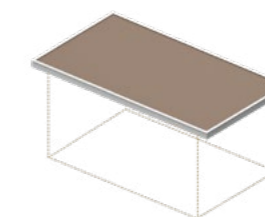

Mensola in cuoio per elementi sospesi  
Shelf in leather for hanging elements

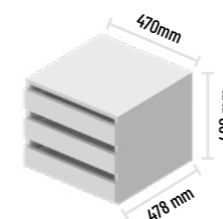

Portacamicie 3 cassetti (per modulo L560-L858)  
3 Drawers shirt-holder (for module L560-L858)

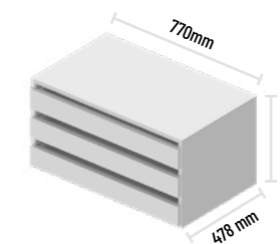

Portacamicie 3 cassetti (per modulo L860-L1158)  
3 Drawers shirt-holder (for module L860-L1158)

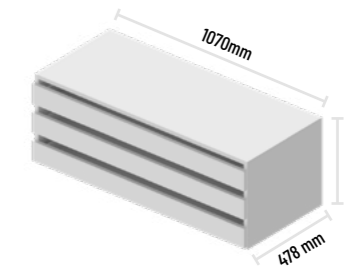

Portacamicie 3 cassetti (per modulo L1200)  
3 Drawers shirt-holder (for module L1200)

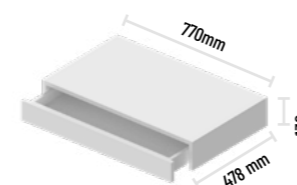

Portacravatte (per modulo L860-L1158)  
Ties hanger (for module L860-L1158)

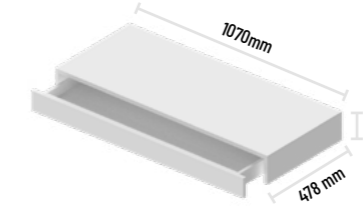

Portacravatte (per modulo L1200)  
Ties hanger (for module L1200)

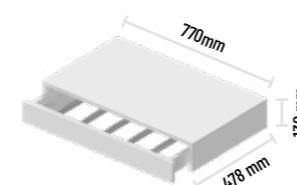

Portapantaloni (per modulo L860-L1158)  
Trousers hanger (for module L860-L1158)

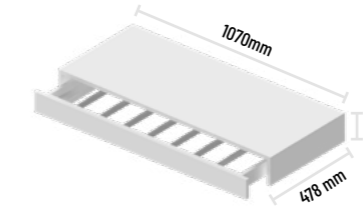

Portapantaloni (per modulo L1200)  
Trousers hanger (for module L1200)

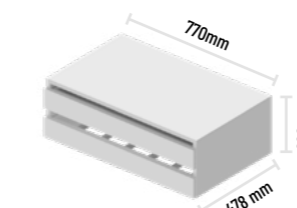

Portapantaloni e cravatte (per modulo L860-L1158)  
Trousers and ties hanger (for module L860-L1158)

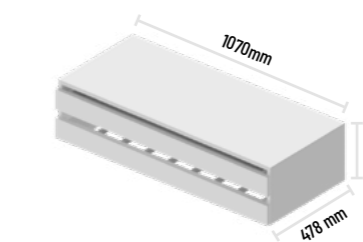

Portapantaloni e cravatte (per modulo L1200)  
Trousers and ties hanger (for module L1200)

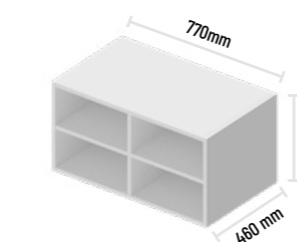

Mobile a giorno (per modulo L860-L1158)  
Open base unit (for module L860-L1158)

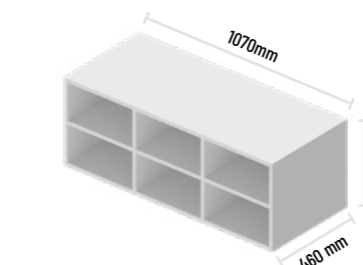

Mobile a giorno (per modulo L1200)  
Open base unit (for module L1200)

# Elementi cabina armadio

## Walk-in closet elements

### Elementi in appoggio / Elements on support

#### 1 ELEMENTO IN APPOGGIO / ELEMENT ON SUPPORT

Tipologia elemento Element typology	L modulo L module	Legno / Wood				Cuoio / Leather		Legno* Wood*	Cuoio** Leather**
		Nobilitato Nobilitato Cat. 1	Nobilitato Nobilitato Cat. 2	Laccato Lacquered Cat. 3	Essenza legno Wood essence Cat. 4	Cat. 5			
Cassettiera 2 cassetto 2 drawer container	L860-L1158	€ 534	€ 752	€ 813	€ 1.092	€ 1.153	S05511X	S05518X	
	L1200	€ 595	€ 825	€ 898	€ 1.201	€ 1.262	S05521X	S05528X	
Cassettiera 3 cassetti 3 drawer container	L860-L1158	€ 655	€ 886	€ 959	€ 1.335	€ 1.395	S05531X	S05538X	
	L1200	€ 764	€ 946	€ 995	€ 1.480	€ 1.541	S05541X	S05548X	
Cassettiera 4 cassetti 4 drawer container	L860-L1158	€ 777	€ 1.007	€ 1.153	€ 1.565	€ 1.687	S05551X	S05558X	
	L1200	€ 922	€ 1.153	€ 1.310	€ 1.735	€ 2.305	S05561X	S05568X	

\*al momento dell'ordine specificare le maniglie: Triennale Fango (X=3), Triennale Testa di Moro (X=C), Brera (X=6), Cadorna (X=9)

\*\*when ordering, specify the handles: Triennale Fango (X = 3), Triennale Testa di Moro (X = C), Brera (X = 6), Cadorna (X = 9)

\*\*\*al momento dell'ordine specificare le maniglie: Triennale Fango (X=3), Triennale Testa di Moro (X=C)

\*\*\*\*when ordering, specify the handles: Triennale Fango (X = 3), Triennale Testa di Moro (X = C)

#### 2 KIT PER ELEMENTI IN APPOGGIO / KIT FOR ELEMENT ON SUPPORT

Tipologia elemento in appoggio Typology element in appoggio	Prezzo Price	Cod.
Kit per cassettiera su ruote / Kit for drawer container on wheel	€ 85	S059900
Kit per cassettiera su mensola fondo* / kit for drawer container on lowest shelf*	€ 85	S059800

\*ordinare separatamente una Mensola fondo adatta alla larghezza del modulo in cui si vuole inserire l'elemento in appoggio

\*\*order separately a Lower shelf suitable for the width of the module in which you want to insert the element on support

#### 3 SCHIENALE PER ELEMENTO PER POSIZIONAMENTO A GIORNO / BACK ELEMENT OPEN

Elementi compatibili Compatible elements	L modulo L module	Legno / Wood				Cuoio / Leather		Legno Wood	Cuoio Leather
		Cat. 1	Cat. 2	Cat. 3	Cat. 4	Cat. 5			
Cassettiera 2 cassetti 2 drawer container	L860-L1158	€ 36	€ 44	€ 79	€ 127	€ 79	S058910	S058980	
	L1200	€ 42	€ 50	€ 103	€ 158	€ 103	S059010	S059080	
Cassettiera 3 cassetti 3 drawer container	L860-L1158	€ 42	€ 50	€ 85	€ 133	€ 85	S059210	S059280	
	L1200	€ 49	€ 56	€ 97	€ 146	€ 97	S059310	S059380	
Cassettiera 4 cassetti 4 drawer container	L860-L1158	€ 49	€ 56	€ 91	€ 140	€ 91	S059410	S059480	
	L1200	€ 55	€ 62	€ 103	€ 146	€ 103	S059510	S059580	

#### 4 TOP CASSETTIERA CON FONDO IN CUOIO / UPPER DRAWER WITH BOTTOM IN LEATHER

Elementi compatibili Compatible elements	L modulo L module	Cuoio Leather	Cod.
Cassettiera 1, 2 o 3 cassetti 1, 2 or 3 drawer container	L560-L858	€ 303	S079600
	L860-L1158	€ 352	S079700

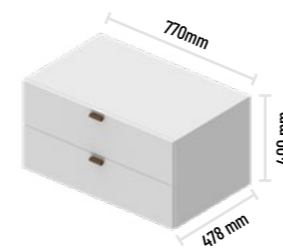

Cassettiera 2 cassetti (per modulo L860-L1158)  
2 Drawer container (for module L860-L1158)

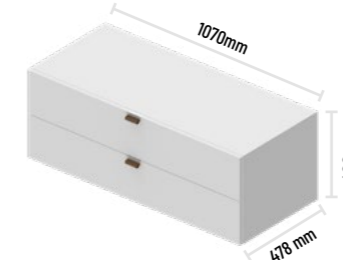

Cassettiera 2 cassetti (per modulo L1200)  
2 Drawer container (for module L1200)

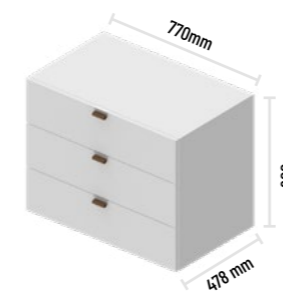

Cassettiera 3 cassetti (per modulo L860-L1158)  
3 Drawer container (for module L860-L1158)

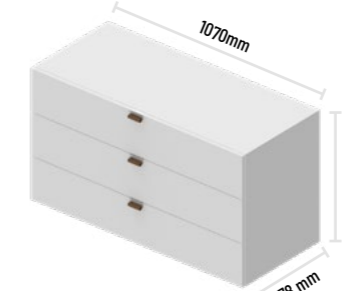

Cassettiera 3 cassetti (per modulo L1200)  
3 Drawer container (for module L1200)

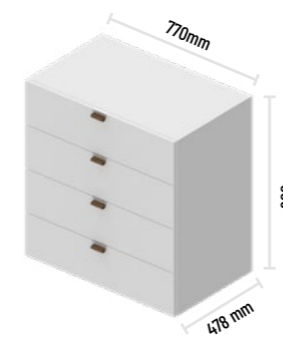

Cassettiera 4 cassetti (per modulo L860-L1158)  
4 Drawer container (for module L860-L1158)

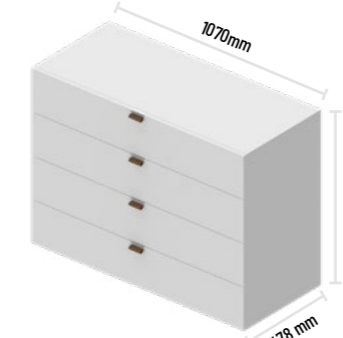

Cassettiera 4 cassetti (per modulo L1200)  
4 Drawer container (for module L1200)



Kit per cassettiera su ruote  
Kit for drawer container on wheel

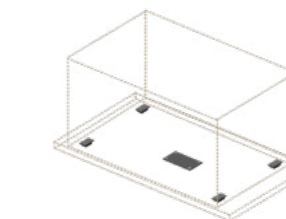

Kit per cassettiera su mensola fondo  
Kit for drawer container on lowest shelf

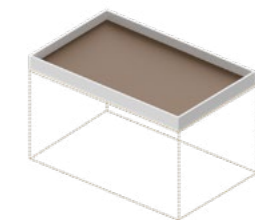

Top cassettiera con fondo in cuoio  
Upper drawer with bottom in leather



Triennale



Brera



Cadorna



# Schienali cabina armadio

## Walk-in closet back panels

### Schienali per cabine armadio a parete

#### Back panels for walk-in closet on wall

##### SCHIENALE IN LEGNO / BACK PANEL IN WOOD

H struttura H structure	L modulo L module	Legno / Wood				Legno Wood
		Nobilitato Nobilitato Cat. 1	Nobilitato Nobilitato Cat. 2	Laccato Lacquered Cat. 3	Essenza legno Wood essence Cat. 4	
H2200	L230-L449	€ 277	€ 303	€ 400	€ 455	S033210
	L450	€ 216	€ 243	€ 340	€ 394	S033110
	L451-L599	€ 289	€ 328	€ 459	€ 570	S034010
	L600	€ 228	€ 267	€ 398	€ 510	S033910
	L601-L899	€ 313	€ 376	€ 576	€ 789	S034810
	L900	€ 252	€ 315	€ 516	€ 728	S034710
	L901-L1199	€ 337	€ 419	€ 695	€ 940	S035610
	L1200	€ 277	€ 358	€ 635	€ 880	S035510
	H2400	L230-L449	€ 280	€ 309	€ 415	€ 482
L450		€ 220	€ 249	€ 354	€ 422	S033310
L451-L599		€ 293	€ 337	€ 479	€ 607	S034210
L600		€ 232	€ 276	€ 419	€ 546	S034110
L601-L899		€ 319	€ 385	€ 607	€ 846	S035010
L900		€ 258	€ 325	€ 546	€ 786	S034910
L901-L1199		€ 346	€ 434	€ 736	€ 1.053	S035810
L1200		€ 285	€ 373	€ 675	€ 992	S035710
H2600		L230-L449	€ 284	€ 315	€ 430	€ 510
	L450	€ 223	€ 255	€ 369	€ 449	S033510
	L451-L599	€ 297	€ 346	€ 500	€ 643	S034410
	L600	€ 237	€ 285	€ 439	€ 582	S034310
	L601-L899	€ 325	€ 394	€ 637	€ 904	S035210
	L900	€ 265	€ 334	€ 576	€ 843	S035110
	L901-L1199	€ 354	€ 449	€ 777	€ 1.165	S036010
	L1200	€ 294	€ 388	€ 716	€ 1.104	S035910



Schienale in legno per cabine armadio a parete  
Back in wood for walk-in closet on wall

##### SCHIENALE IN VETRO / BACK PANEL IN GLASS

H struttura H structure	P mensola Depth shelves	Vetro / Glass		Vetro Glass
		Cat. C*	Cat. D*	
H2200	L230-L449	€ 478	€ 512	S033200
	L450	€ 393	€ 427	S033100
	L451-L599	€ 546	€ 591	S034000
	L600	€ 461	€ 506	S033900
	L601-L899	€ 681	€ 750	S034800
	L900	€ 596	€ 665	S034700
	L901-L1199	€ 815	€ 908	S035600
	L1200	€ 730	€ 823	S035500
	H2400	L230-L449	€ 499	€ 536
L450		€ 414	€ 451	S033300
L451-L599		€ 572	€ 621	S034200
L600		€ 487	€ 536	S034100
L601-L899		€ 797	€ 886	S035000
L900		€ 712	€ 801	S034900
L901-L1199		€ 864	€ 965	S035800
L1200		€ 779	€ 880	S035700
H2600		L230-L449	€ 519	€ 559
	L450	€ 434	€ 474	S033500
	L451-L599	€ 598	€ 652	S034400
	L600	€ 513	€ 567	S034300
	L601-L899	€ 912	€ 1.022	S035200
	L900	€ 828	€ 937	S035100
	L901-L1199	€ 912	€ 1.022	S036000
	L1200	€ 828	€ 937	S035900



Schienale in vetro per cabine armadio a parete  
Back in glass for walk-in closet on wall

##### SCHIENALE IN LEGNO PER MODULI ANGOLARI / BACK PANEL IN WOOD FOR CORNER MODULES

H struttura H structure	P mensola Depth shelves	Legno / Wood				Legno Wood
		Cat. 1	Cat. 2	Cat. 3	Cat. 4	
H2200	P300	€ 205	€ 224	€ 288	€ 353	S038110
	P500	€ 222	€ 254	€ 366	€ 443	S038510
H2400	P300	€ 217	€ 237	€ 309	€ 376	S038210
	P500	€ 234	€ 267	€ 400	€ 482	S038610
H2600	P300	€ 229	€ 249	€ 325	€ 398	S038310
	P500	€ 246	€ 279	€ 427	€ 512	S038710



Schienale in legno per moduli angolari  
per cabine armadio a parete  
Back in wood for corner modules  
for walk-in closet on wall

##### SCHIENALE IN VETRO PER MODULI ANGOLARI / BACK PANEL IN GLASS FOR CORNER MODULES

H struttura H structure	P mensola Depth shelves	Vetro / Glass		Vetro Glass
		Cat. C*	Cat. D*	
H2200	P300	€ 335	€ 358	S038100
	P500	€ 425	€ 464	S038500
H2400	P300	€ 351	€ 393	S038200
	P500	€ 448	€ 491	S038600
H2600	P300	€ 366	€ 427	S038300
	P500	€ 471	€ 518	S038700

\*solo vetri opachi  
\*only opaque glass



Schienale in vetro per moduli angolari  
per cabine armadio a parete  
Back in glass for corner modules  
for walk-in closet on wall

# Schienali cabina armadio

## Walk-in closet back panels

### Schienali per cabine armadio a soffitto

#### Back panels for walk-in closet on ceiling

##### SCHIENALE IN LEGNO / BACK PANEL IN WOOD

H struttura H structure	L modulo L module	Legno / Wood				Legno Wood
		Nobilitato Nobilitato Cat. 1	Nobilitato Nobilitato Cat. 2	Laccato Lacquered Cat. 3	Essenza legno Wood essence Cat. 4	
H1000 - H2300	L230-L449	€ 277	€ 303	€ 400	€ 455	S080210
	L450	€ 216	€ 243	€ 340	€ 394	S080110
	L451-L599	€ 289	€ 328	€ 459	€ 570	S081010
	L600	€ 228	€ 267	€ 398	€ 510	S080910
	L601-L899	€ 313	€ 376	€ 576	€ 789	S081810
	L900	€ 252	€ 315	€ 516	€ 728	S081710
	L901-L1199	€ 337	€ 419	€ 695	€ 940	S082610
	L1200	€ 277	€ 358	€ 635	€ 880	S082510
H2300 - H2700	L230-L449	€ 284	€ 315	€ 430	€ 510	S080410
	L450	€ 223	€ 255	€ 369	€ 449	S080310
	L451-L599	€ 297	€ 346	€ 500	€ 643	S081210
	L600	€ 237	€ 285	€ 439	€ 582	S081110
	L601-L899	€ 325	€ 394	€ 637	€ 904	S082010
	L900	€ 265	€ 334	€ 576	€ 843	S081910
	L901-L1199	€ 354	€ 449	€ 777	€ 1.165	S082810
	L1200	€ 294	€ 388	€ 716	€ 1.104	S082710
H2700 - H3000	L230-L449	€ 296	€ 328	€ 451	€ 516	S080610
	L450	€ 235	€ 267	€ 391	€ 455	S080510
	L451-L599	€ 309	€ 358	€ 529	€ 649	S081410
	L600	€ 249	€ 297	€ 468	€ 588	S081310
	L601-L899	€ 337	€ 419	€ 683	€ 1.001	S082210
	L900	€ 277	€ 358	€ 622	€ 940	S082110
	L901-L1199	€ 366	€ 473	€ 837	€ 1.183	S083010
	L1200	€ 306	€ 413	€ 777	€ 1.122	S082910
H3000 - H3200	L230-L449	€ 308	€ 334	€ 467	€ 540	S080810
	L450	€ 248	€ 273	€ 406	€ 479	S080710
	L451-L599	€ 322	€ 364	€ 548	€ 770	S081610
	L600	€ 261	€ 303	€ 488	€ 710	S081510
	L601-L899	€ 349	€ 425	€ 713	€ 1.044	S082410
	L900	€ 289	€ 364	€ 653	€ 983	S082310
	L901-L1199	€ 379	€ 491	€ 877	€ 1.250	S083210
	L1200	€ 318	€ 431	€ 817	€ 1.189	S083110



Schienale in legno per cabine armadio a soffitto  
Back in wood for walk-in closet on ceiling



Schienale in legno per moduli angolari  
per cabine armadio a soffitto  
Back in wood for corner modules  
for walk-in closet on ceiling

##### SCHIENALE IN LEGNO PER MODULI ANGOLARI / BACK PANEL IN WOOD FOR CORNER MODULES

H struttura H structure	L modulo L module	Legno / Wood				Legno Wood
		Cat. 1	Cat. 2	Cat. 3	Cat. 4	
H1000 -	P300	€ 205	€ 224	€ 288	€ 353	S084110
H2300	P500	€ 222	€ 254	€ 366	€ 443	S084510
H2300 - H2700	P300	€ 217	€ 237	€ 309	€ 376	S084210
	P500	€ 234	€ 267	€ 400	€ 482	S084610
H2700 - H3000	P300	€ 229	€ 249	€ 325	€ 398	S084310
	P500	€ 246	€ 279	€ 427	€ 512	S084710
H3000 - H3200	P300	€ 241	€ 261	€ 337	€ 408	S084410
	P500	€ 258	€ 291	€ 444	€ 531	S084810

##### SCHIENALE IN VETRO / BACK PANEL IN GLASS

H struttura H structure	L modulo L module	Vetro / Glass				Vetro Glass
		Cat. A	Cat. B	Cat. C	Cat. D	
H1000 - H2300	L230-L449	€ 400	€ 440	€ 478	€ 512	S080200
	L450	€ 315	€ 347	€ 393	€ 427	S080100
	L451-L599	€ 442	€ 486	€ 546	€ 591	S081000
	L600	€ 357	€ 392	€ 461	€ 506	S080900
	L601-L899	€ 523	€ 575	€ 681	€ 750	S081800
	L900	€ 438	€ 482	€ 596	€ 665	S081700
	L901-L1199	€ 604	€ 665	€ 815	€ 908	S082600
	L1200	€ 519	€ 571	€ 730	€ 823	S082500
H2300 - H2700	L230-L449	€ 430	€ 472	€ 519	€ 559	S080400
	L450	€ 345	€ 379	€ 434	€ 474	S080300
	L451-L599	€ 476	€ 523	€ 598	€ 652	S081200
	L600	€ 391	€ 430	€ 513	€ 567	S081100
	L601-L899	€ 570	€ 627	€ 912	€ 1.022	S082000
	L900	€ 485	€ 534	€ 828	€ 937	S081900
	L901-L1199	€ 664	€ 730	€ 912	€ 1.022	S082800
	L1200	€ 579	€ 637	€ 828	€ 937	S082700
H2700 - H3000	L230-L449	€ 450	€ 495	€ 551	€ 595	S080600
	L450	€ 365	€ 402	€ 466	€ 510	S080500
	L451-L599	€ 502	€ 553	€ 637	€ 696	S081400
	L600	€ 417	€ 459	€ 552	€ 612	S081300
	L601-L899	€ 605	€ 666	€ 812	€ 902	S082200
	L900	€ 521	€ 573	€ 727	€ 817	S082100
	L901-L1199	€ 710	€ 781	€ 985	€ 1.105	S083000
	L1200	€ 625	€ 687	€ 900	€ 1.020	S082900
H3000 - H3200	L230-L449	€ 464	€ 510	€ 572	€ 619	S080800
	L450	€ 379	€ 416	€ 487	€ 534	S080700
	L451-L599	€ 519	€ 571	€ 664	€ 727	S081610
	L600	€ 434	€ 478	€ 579	€ 642	S081500
	L601-L899	€ 630	€ 693	€ 848	€ 944	S082400
	L900	€ 545	€ 599	€ 763	€ 859	S082300
	L901-L1199	€ 739	€ 813	€ 1.034	€ 1.162	S083200
	L1200	€ 654	€ 719	€ 949	€ 1.077	S083100



Schienale in vetro per cabine armadio a soffitto  
Back in glass for walk-in closet on ceiling



Schienale in vetro per moduli angolari  
per cabine armadio a soffitto  
Back in glass for corner modules  
for walk-in closet on ceiling

##### SCHIENALE IN VETRO PER MODULI ANGOLARI / BACK PANEL IN GLASS FOR CORNER MODULES

H struttura H structure	L modulo L module	Vetro / Glass				Vetro Glass
		Cat. A	Cat. B	Cat. C	Cat. D	
H1000 -	P300	€ 280	€ 308	€ 335	€ 358	S084100
H2300	P500	€ 335	€ 368	€ 425	€ 464	S084500
H2300 - H2700	P300	€ 303	€ 334	€ 366	€ 427	S084200
	P500	€ 366	€ 403	€ 471	€ 518	S084600
H2700 - H3000	P300	€ 322	€ 354	€ 391	€ 422	S084300
	P500	€ 389	€ 428	€ 506	€ 558	S084700
H3000 - H3200	P300	€ 331	€ 364	€ 406	€ 439	S084400
	P500	€ 405	€ 446	€ 530	€ 584	S084800

# Schienali cabina armadio

## Walk-in closet back panels

### Schienali per cabine armadio freestanding

#### Back panels for freestanding walk-in closet

##### SCHIENALE IN LEGNO / BACK PANEL IN WOOD

H struttura H structure	L modulo L module	Legno / Wood				Legno Wood
		Nobilitato Nobilitato Cat. 1	Nobilitato Nobilitato Cat. 2	Laccato Lacquered Cat. 3	Essenza legno Wood essence Cat. 4	
H2200	L230-L449	€ 277	€ 291	€ 425	€ 461	S030210
	L450	€ 216	€ 231	€ 364	€ 400	S030110
	L451-L599	€ 223	€ 261	€ 437	€ 510	S030410
	L600	€ 284	€ 322	€ 497	€ 570	S030310
	L601-L899	€ 296	€ 364	€ 631	€ 789	S030610
	L900	€ 235	€ 303	€ 570	€ 728	S030510
	L901-L1199	€ 308	€ 413	€ 764	€ 946	S030810
H2400	L1200	€ 248	€ 352	€ 704	€ 886	S030710
	L230-L449	€ 297	€ 303	€ 449	€ 588	S031010
	L450	€ 237	€ 243	€ 388	€ 528	S030910
	L451-L599	€ 315	€ 334	€ 522	€ 704	S031210
	L600	€ 255	€ 273	€ 461	€ 643	S031110
	L601-L899	€ 340	€ 376	€ 667	€ 934	S031410
	L900	€ 279	€ 315	€ 607	€ 874	S031310
H2600	L901-L1199	€ 340	€ 376	€ 667	€ 934	S031610
	L1200	€ 315	€ 364	€ 752	€ 1.104	S031510
	L230-L449	€ 303	€ 315	€ 467	€ 601	S031810
	L450	€ 243	€ 255	€ 406	€ 540	S031710
	L451-L599	€ 322	€ 340	€ 546	€ 716	S032010
	L600	€ 261	€ 279	€ 485	€ 655	S031910
	L601-L899	€ 352	€ 388	€ 710	€ 946	S032210
H2600	L900	€ 291	€ 328	€ 649	€ 886	S032110
	L901-L1199	€ 388	€ 443	€ 874	€ 1.177	S032410
	L1200	€ 328	€ 382	€ 813	€ 1.116	S032310

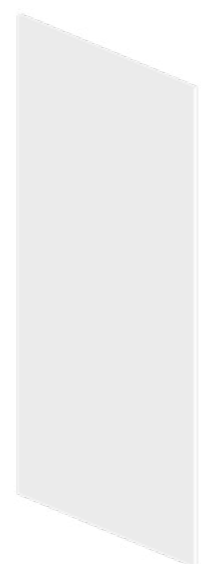

Schienale in legno per cabine armadio freestanding  
Back in wood for freestanding walk-in closet

##### SCHIENALE IN VETRO / BACK PANEL IN GLASS

H struttura H structure	L modulo L module	Vetro / Glass					Vetro Glass
		Cat. A	Cat. B	Cat. C	Cat. D	Cat. E	
H2200	L230-L449	€ 399	€ 444	€ 476	€ 501	€ 818	S030200
	L450	€ 314	€ 359	€ 391	€ 416	€ 733	S030100
	L451-L599	€ 433	€ 491	€ 534	€ 567	€ 985	S030400
	L600	€ 348	€ 406	€ 449	€ 482	€ 900	S030300
	L601-L899	€ 510	€ 599	€ 664	€ 715	€ 1.357	S030600
	L900	€ 425	€ 514	€ 579	€ 630	€ 1.272	S030500
	L901-L1199	€ 582	€ 703	€ 789	€ 789	€ 1.715	S030800
H2400	L1200	€ 497	€ 618	€ 704	€ 704	€ 1.630	S030700
	L230-L449	€ 416	€ 465	€ 499	€ 527	€ 872	S031000
	L450	€ 331	€ 380	€ 414	€ 442	€ 787	S030900
	L451-L599	€ 453	€ 517	€ 562	€ 598	€ 1.054	S031200
	L600	€ 368	€ 432	€ 477	€ 513	€ 969	S031100
	L601-L899	€ 534	€ 632	€ 703	€ 758	€ 1.457	S031400
	L900	€ 449	€ 547	€ 618	€ 673	€ 1.372	S031300
H2600	L901-L1199	€ 613	€ 744	€ 837	€ 912	€ 1.848	S031600
	L1200	€ 528	€ 659	€ 752	€ 828	€ 1.763	S031500
	L230-L449	€ 432	€ 485	€ 523	€ 552	€ 927	S031800
	L450	€ 347	€ 400	€ 438	€ 467	€ 842	S031700
	L451-L599	€ 472	€ 541	€ 591	€ 630	€ 1.124	S032000
	L600	€ 387	€ 456	€ 506	€ 545	€ 1.039	S031900
	L601-L899	€ 559	€ 665	€ 741	€ 802	€ 1.559	S032200
H2600	L900	€ 474	€ 580	€ 656	€ 717	€ 1.474	S032100
	L901-L1199	€ 643	€ 785	€ 887	€ 967	€ 1.981	S032400
	L1200	€ 558	€ 700	€ 802	€ 882	€ 1.897	S032300



Schienale in vetro per cabine armadio freestanding  
Back in glass for freestanding walk-in closet

# Fianchi cabina armadio

## Walk-in closet sides

### Fianchi per cabine armadio freestanding

#### Sides for freestanding walk-in closet

##### FIANCO IN VETRO / SIDE IN GLASS

H struttura H structure	Vetro / Glass				Vetro Glass
	Cat. A	Cat. B	Cat. C	Cat. D	
L2200	€ 158	€ 218	€ 255	€ 291	S039100
L2400	€ 170	€ 231	€ 279	€ 311	S039200
L2600	€ 182	€ 249	€ 297	€ 332	S039300

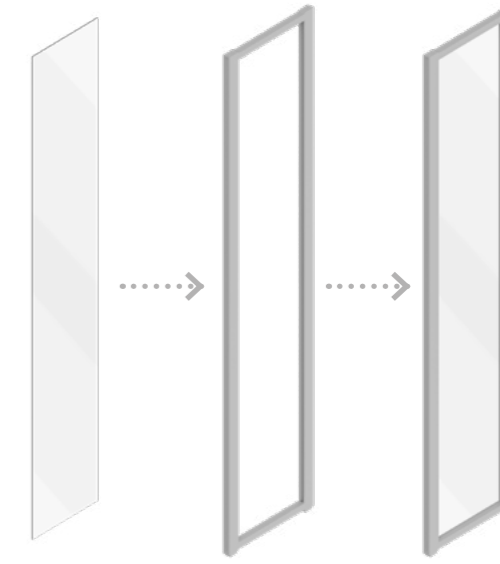

Fianco in vetro  
Side in glass

Struttura Freestanding  
Freestanding structure  
p. 309

Struttura Freestanding  
con fianco in vetro  
Freestanding structure  
with side in glass

# Ante cabina armadio

## Walk-in closet doors

### Ante per cabine armadio freestanding

#### Doors for freestanding walk-in closet

#### ANTA IN LEGNO\* / DOOR IN WOOD\*

H struttura H structure	L modulo L module	Legno / Wood				Legno* Wood*
		Nobilitato Nobilitato Cat. 1	Nobilitato Nobilitato Cat. 2	Laccato Lacquered Cat. 3	Essenza legno Wood essence Cat. 4	
H2200	L230-L449	€ 376	€ 413	€ 546	€ 704	S04021X
	L450	€ 315	€ 352	€ 485	€ 643	S04011X
	L451-L599	€ 388	€ 431	€ 601	€ 813	S04061X
	L600	€ 328	€ 370	€ 540	€ 752	S04051X
H2400	L230-L449	€ 388	€ 425	€ 570	€ 728	S04171X
	L450	€ 328	€ 364	€ 510	€ 667	S04181X
	L451-L599	€ 400	€ 443	€ 643	€ 837	S04211X
	L600	€ 340	€ 382	€ 582	€ 777	S04221X
H2600	L230-L449	€ 400	€ 437	€ 607	€ 764	S04341X
	L450	€ 340	€ 376	€ 546	€ 704	S04331X
	L451-L599	€ 413	€ 455	€ 667	€ 898	S04371X
	L600	€ 352	€ 394	€ 607	€ 837	S04381X

\*Il prezzo non comprende la maniglia. Al momento dell'ordine specificare nel codice il senso di apertura e la tipologia di maniglia:  
 - Anta destra: Senza maniglia (x=0), Triennale Fango +€43 (X=1), Triennale Testa di Moro +€43 (X=A), Brera +€122 (X=4), Zara +€98 (X=7)  
 - Anta sinistra: Senza maniglia (x=0), Triennale Fango +€43 (X=2), Triennale Testa di Moro +€43 (X=B), Brera +€122 (X=5), Zara +€98 (X=8)  
 \*Price does not include handle. When ordering, specify in the code the opening direction and the handle typology:  
 - Right door: Without handle (x = 0), Triennale Fango +€43 (X=1), Triennale Testa di Moro +€43 (X=A), Brera +€122 (X=4), Zara +€98 (X=7)  
 - Left door: Without handle (x = 0), Triennale Fango +€43 (X=2), Triennale Testa di Moro +€43 (X=B), Brera +€122 (X=5), Zara +€98 (X=8)

#### ANTA IN VETRO\* / DOOR IN GLASS\*

H struttura H structure	L modulo L module	Vetro / Glass					Vetro* Glass*
		Cat. A	Cat. B	Cat. C	Cat. D	Cat. E	
H2200	L230-L449	€ 551	€ 596	€ 627	€ 653	€ 972	S04020X
	L450	€ 466	€ 511	€ 542	€ 568	€ 887	S04010X
	L451-L599	€ 565	€ 625	€ 669	€ 703	€ 1.130	S04060X
	L600	€ 480	€ 540	€ 584	€ 618	€ 1.045	S04050X
H2400	L230-L449	€ 546	€ 595	€ 629	€ 656	€ 1.005	S04180X
	L450	€ 461	€ 510	€ 544	€ 572	€ 920	S04170X
	L451-L599	€ 585	€ 650	€ 696	€ 734	€ 1.200	S04220X
	L600	€ 500	€ 565	€ 612	€ 649	€ 1.115	S04210X
H2600	L230-L449	€ 562	€ 615	€ 653	€ 683	€ 1.060	S04340X
	L450	€ 477	€ 530	€ 568	€ 598	€ 976	S04330X
	L451-L599	€ 604	€ 675	€ 726	€ 766	€ 1.272	S04380X
	L600	€ 519	€ 590	€ 641	€ 681	€ 1.187	S04370X

\*Il prezzo non comprende la maniglia. Al momento dell'ordine specificare nel codice il senso di apertura e la tipologia di maniglia:  
 - Anta destra: Senza maniglia (x=0), Triennale Fango +€43 (X=1), Triennale Testa di Moro +€43 (X=A), Brera +€122 (X=4), Zara +€98 (X=7)  
 - Anta sinistra: Senza maniglia (x=0), Triennale Fango +€43 (X=2), Triennale Testa di Moro +€43 (X=B), Brera +€122 (X=5), Zara +€98 (X=8)  
 \*Price does not include handle. When ordering, specify in the code the opening direction and the handle typology:  
 - Right door: Without handle (x = 0), Triennale Fango +€43 (X=1), Triennale Testa di Moro +€43 (X=A), Brera +€122 (X=4), Zara +€98 (X=7)  
 - Left door: Without handle (x = 0), Triennale Fango +€43 (X=2), Triennale Testa di Moro +€43 (X=B), Brera +€122 (X=5), Zara +€98 (X=8)

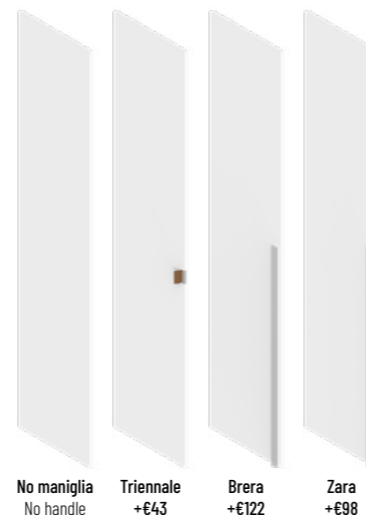

### Ante per cabine armadio in nicchia

#### Doors for walk-in closet niche

#### ANTA IN LEGNO\* / DOOR IN WOOD\*

H struttura H structure	L modulo L module	Legno / Wood				Legno* Wood*
		Nobilitato Nobilitato Cat. 1	Nobilitato Nobilitato Cat. 2	Laccato Lacquered Cat. 3	Essenza legno Wood essence Cat. 4	
H1000 - H2000	L230-L449	€ 376	€ 413	€ 546	€ 704	S04041X
	L450	€ 315	€ 352	€ 485	€ 643	S04031X
	L451-L599	€ 388	€ 431	€ 601	€ 813	S04081X
	L600	€ 328	€ 370	€ 540	€ 752	S04071X
H2200 - H2400	L230-L449	€ 388	€ 425	€ 570	€ 728	S04201X
	L450	€ 328	€ 364	€ 510	€ 667	S04191X
	L451-L599	€ 400	€ 443	€ 643	€ 837	S04241X
	L600	€ 340	€ 382	€ 582	€ 777	S04231X
H2400 - H2600	L230-L449	€ 400	€ 437	€ 607	€ 764	S04361X
	L450	€ 340	€ 376	€ 546	€ 704	S04351X
	L451-L599	€ 413	€ 455	€ 667	€ 898	S04401X
	L600	€ 352	€ 394	€ 607	€ 837	S04391X
H2600 - H2800	L230-L449	€ 413	€ 449	€ 643	€ 801	S04501X
	L450	€ 352	€ 388	€ 582	€ 740	S04491X
	L451-L599	€ 425	€ 467	€ 692	€ 922	S04521X
	L600	€ 364	€ 406	€ 631	€ 861	S04511X

\*Il prezzo non comprende la maniglia. Al momento dell'ordine specificare nel codice il senso di apertura e la tipologia di maniglia:  
 - Anta destra: Senza maniglia (x=0), Triennale Fango +€43 (X=1), Triennale Testa di Moro +€43 (X=A), Brera +€122 (X=4), Zara +€98 (X=7)  
 - Anta sinistra: Senza maniglia (x=0), Triennale Fango +€43 (X=2), Triennale Testa di Moro +€43 (X=B), Brera +€122 (X=5), Zara +€98 (X=8)  
 \*Price does not include handle. When ordering, specify in the code the opening direction and the handle typology:  
 - Right door: Without handle (x = 0), Triennale Fango +€43 (X=1), Triennale Testa di Moro +€43 (X=A), Brera +€122 (X=4), Zara +€98 (X=7)  
 - Left door: Without handle (x = 0), Triennale Fango +€43 (X=2), Triennale Testa di Moro +€43 (X=B), Brera +€122 (X=5), Zara +€98 (X=8)

#### ANTA IN VETRO\* / DOOR IN GLASS\*

H struttura H structure	L modulo L module	Vetro / Glass					Vetro* Glass*
		Cat. A	Cat. B	Cat. C	Cat. D	Cat. E	
H1000 - H2000	L230-L449	€ 551	€ 596	€ 627	€ 653	€ 972	S04040X
	L450	€ 466	€ 511	€ 542	€ 568	€ 887	S04030X
	L451-L599	€ 565	€ 625	€ 669	€ 703	€ 1.130	S04080X
	L600	€ 480	€ 540	€ 584	€ 618	€ 1.045	S04070X
H2200 - H2400	L230-L449	€ 546	€ 595	€ 629	€ 656	€ 1.005	S04200X
	L450	€ 461	€ 510	€ 544	€ 572	€ 920	S04190X
	L451-L599	€ 585	€ 650	€ 696	€ 734	€ 1.200	S04240X
	L600	€ 500	€ 565	€ 612	€ 649	€ 1.115	S04230X
H2400 - H2600	L230-L449	€ 562	€ 615	€ 653	€ 683	€ 1.060	S04360X
	L450	€ 477	€ 530	€ 568	€ 598	€ 976	S04350X
	L451-L599	€ 604	€ 675	€ 726	€ 766	€ 1.272	S04400X
	L600	€ 519	€ 590	€ 641	€ 681	€ 1.187	S04390X
H2600 - H2800	L230-L449	€ 579	€ 636	€ 676	€ 709	€ 1.115	S04500X
	L450	€ 494	€ 551	€ 591	€ 624	€ 1.030	S04490X
	L451-L599	€ 624	€ 700	€ 755	€ 798	€ 1.342	S04520X
	L600	€ 539	€ 615	€ 670	€ 713	€ 1.257	S04510X

\*Il prezzo non comprende la maniglia. Al momento dell'ordine specificare nel codice il senso di apertura e la tipologia di maniglia:  
 - Anta destra: Senza maniglia (x=0), Triennale Fango +€43 (X=1), Triennale Testa di Moro +€43 (X=A), Brera +€122 (X=4), Zara +€98 (X=7)  
 - Anta sinistra: Senza maniglia (x=0), Triennale Fango +€43 (X=2), Triennale Testa di Moro +€43 (X=B), Brera +€122 (X=5), Zara +€98 (X=8)  
 \*Price does not include handle. When ordering, specify in the code the opening direction and the handle typology:  
 - Right door: Without handle (x = 0), Triennale Fango +€43 (X=1), Triennale Testa di Moro +€43 (X=A), Brera +€122 (X=4), Zara +€98 (X=7)  
 - Left door: Without handle (x = 0), Triennale Fango +€43 (X=2), Triennale Testa di Moro +€43 (X=B), Brera +€122 (X=5), Zara +€98 (X=8)

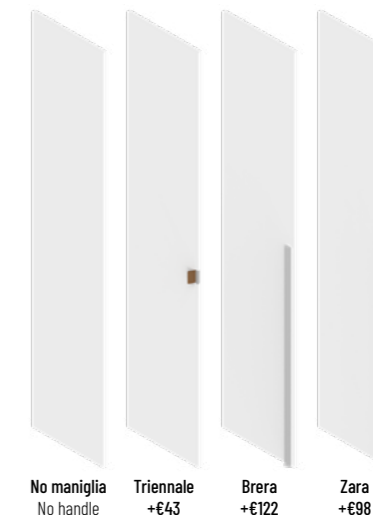

Informazioni generali / General informations  
 Porte battenti con cornice / Hinged door and frame  
 Porte effetto filomuro / Flush-effect door  
 Porte filomuro / Flush door  
 Porte senza falso telaio / Door w/o basic door frame  
 Porte a scomparsa / Pocket door  
 Pan. scorrevoli o girevoli / Sliding or pivoting panels  
 Partiti divisorie / Partition wall  
 Boiserie / Boiserie  
 Cabine armadio / Walk-in closet  
 Librerie / Bookcase  
 Tavoli / Table

Informazioni generali / General informations  
 Porte battenti con cornice / Hinged door and frame  
 Porte effetto filomuro / Flush-effect door  
 Porte filomuro / Flush door  
 Porte senza falso telaio / Door w/o basic door frame  
 Porte a scomparsa / Pocket door  
 Pan. scorrevoli o girevoli / Sliding or pivoting panels  
 Partiti divisorie / Partition wall  
 Boiserie / Boiserie  
 Cabine armadio / Walk-in closet  
 Librerie / Bookcase  
 Tavoli / Table

# Elementi cabina armadio

## Walk-in closet elements

### Cassettiere a isola / Container island

#### CASSETTIERA ISOLA / CONTAINER ISLAND

Tipologia cassettera isola Container island typology	Dimensioni Dimension	Tipologia ripiano superiore Top typology	Legno / Wood				Cod. isola* Island cod.*	Cod. top vetro** Glass top cod.**
			Nobilitato Nobilitato Cat. 1	Nobilitato Nobilitato Cat. 2	Laccato Lacquered Cat. 3	Essenza legno Wood essence Cat. 4		
<b>Piccola (3 cassetti)</b> Small (3 drawers)	H850 x L1115 x P1000	Ripiano legno / Top in wood	€ 2.045	€ 2.496	€ 3.270	€ 3.760	S06011X	S061100
		Ripiano cuoio / Top in leather	€ 2.531	€ 2.934	€ 3.780	€ 4.051	S06018X	S061100
<b>Media (6 cassetti)</b> Medium (6 drawers)	H850 x L1600 x P1000	Ripiano legno / Top in wood	€ 2.773	€ 3.501	€ 4.114	€ 4.634	S06021X	S061200
		Ripiano cuoio / Top in leather	€ 3.745	€ 4.596	€ 4.964	€ 5.119	S06028X	S061200
<b>Grande (6 cassetti)</b> Big (6 drawers)	H850 x L2200 x P1000	Ripiano legno / Top in wood	€ 3.166	€ 3.837	€ 4.750	€ 5.325	S06031X	S061300
		Ripiano cuoio / Top in leather	€ 4.621	€ 4.872	€ 5.690	€ 5.740	S06038X	S061300

\*al momento dell'ordine specificare le maniglie: Triennale Fango (X=3), Triennale Testa di Moro (X=C), Brera (X=6), Cadorna (X=9)

\*when ordering, specify the handles: Triennale Fango (X = 3), Triennale Testa di Moro (X = C), Brera (X = 6), Cadorna (X = 9)

\*\* Top vetro disponibile nelle finiture Bronzo (17), Fumè (15) e Neutro Extrachiaro (64), al momento dell'ordine specificare la finitura

\*\* Glass top available in the finishings Bronzo (17), Fumè (15) e Neutro Extrachiaro (64), when ordering specify the finishing



Cassettiera isola piccola, ripiano in legno  
Small container island, top in wood

Cassettiera isola media, ripiano in legno  
Medium container island, top in wood

Cassettiera isola grande, ripiano in legno  
Big container island, top in wood



Cassettiera isola piccola, ripiano in cuoio  
Small container island, top in leather

Cassettiera isola media, ripiano in cuoio  
Medium container island, top in leather

Cassettiera isola grande, ripiano in cuoio  
Big container island, top in leather

### Elementi speciali / Special elements

#### APPENDIABILI INCLINABILE / RECLINING CLOTHES HANGER

L modulo L module	Alluminio nero Black aluminium	Cod. elemento Element cod.	Cod. supporto* Support cod.*
L900	€ 352	S079800	S079900

\*il supporto non è necessario se l'elemento è posizionato tra due strutture freestanding cieche

\*the support is not necessary if the element is positioned between two freestanding enclosed structures



# Accessori cabina armadio

## Walk-in closet accessories

### Illuminazione / Lighting

#### COPPIA DI PROFILI LED\* PER MODULO CABINA ARMADIO / PAIR OF LED PROFILES\* FOR WALK-IN CLOSET MODULE

Consumo energetico Energy consumption	Alimentazione Power supply	Temperatura colore Colour temperature	Prezzo Price	Codice Codes
20W/m x 2	24V DC	4000K	€ 150	S070500

\* prodotto certificato UL (Underwriters Laboratories) / UL (Underwriters Laboratories) certified product

Al momento dell'ordine specificare il punto del montante da cui far fuoriuscire il cavo di connessione: sopra o sotto  
When ordering, specify the point on the upright from which to run the connecting cable: top or bottom

#### KIT ALIMENTAZIONE / POWER SUPPLY KIT

Potenza erogata Power delivered	Tensione elettrica Electric voltage	Prezzo Price	Codice Codes
75W	24V DC	€ 80	S071300
75W*	24V DC	€ 105	S071600
100W	24V DC	€ 100	S071400
150W	24V DC	€ 130	S071500

\* prodotto certificato UL (Underwriters Laboratories) / UL (Underwriters Laboratories) certified product

#### ACCESSORI ILLUMINAZIONE / LIGHTING ACCESSORIES

Accessori Accessories	Prezzo Price	Codice Codes
Cavo di collegamento 3000mm* / Connecting cable 3000mm*	€ 30	S072100
Sensore accensione Led per anta singola / Led sensor for single door	€ 90	S073100
Sensore accensione Led per anta doppia / Led sensor for double door	€ 125	S073200

\* prodotto certificato UL (Underwriters Laboratories) / UL (Underwriters Laboratories) certified product

### Accessori per elementi / Element accessories

#### ACCESSORIO IN CUOIO PER CASSETTO / ACCESSORY IN LEATHER FOR CONTAINER

L modulo L module	Cuoio / Leather		Cod.	
	[A]	[B]	[A]	[B]
L900	€ 262	€ 345	S079100	S079300
L1200	€ 282	€ 432	S079200	S079400

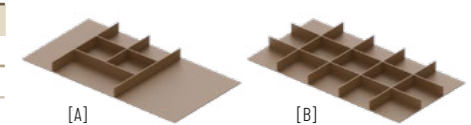

#### SCATOLA IN CUOIO / LEATHER BOX

Dimensioni Dimension	Cuoio Leather	Cod.
P400 x L300 x A150	€ 425	S079500



### Profili di chiusura / Closer profiles

#### PROFILI DI CHIUSURA PER SOLO NICCHIA / CLOSER PROFILES FOR SOLO NICHE

Profilo di chiusura Closing profile	Lunghezza Width	Alluminio Aluminium	Cod.
Coppia fasce laterali / Pair of side bandclosure	L3000	€/ml 49	S017100
Profilo superiore / Upper closing profile	L3000	€/ml 36	S017200



# LIBRERIE BOOKCASES

Una collezione essenziale di librerie completa l'offerta di sistema per l'architettura d'interni. La tecnologia in alluminio e vetro assicura un'altissima qualità nei dettagli costruttivi e la massima durata.

An essential collection of bookcases completes our interior architectural system. Our aluminium and glass technology ensure very high quality construction details, and maximum lifespan.

## Dettagli / Details

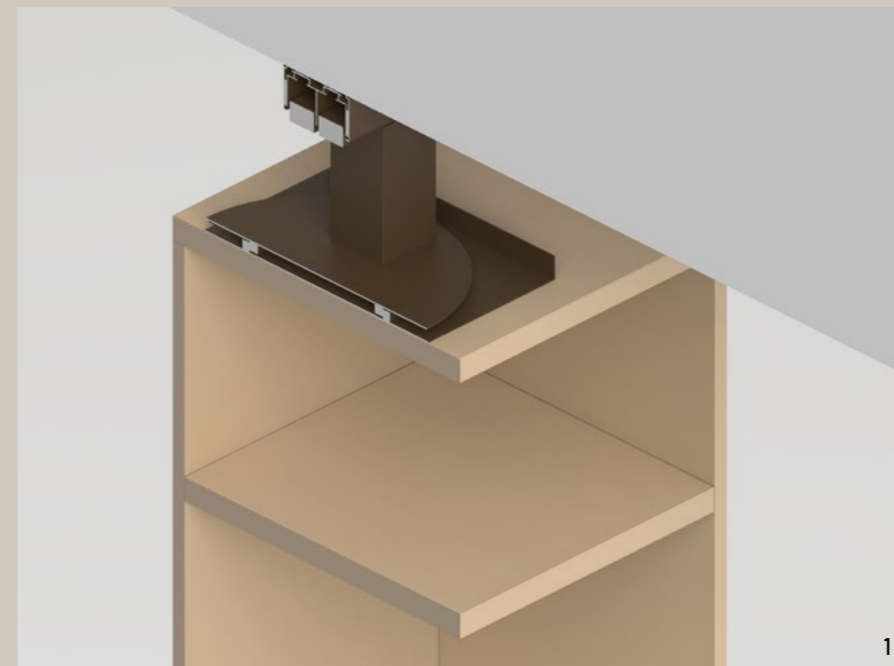

1

**1. Sezione verticale libreria  
Girevole, binario superiore**  
1. Vertical section Girevole  
bookcase, upper rail



2

**2. Sezione verticale libreria  
Girevole, binario inferiore**  
2. Vertical section Girevole  
bookcase, lower rail

# Libreria Girevole

## Girevole bookcase

La soluzione libreria Girevole è la soluzione ideale quando si desidera suddividere in modo dinamico e versatile un ambiente con un sistema di contenimento a moduli mobili. L'innovativo sistema di binari a soffitto e a pavimento può accogliere un numero illimitato di elementi che possono scorrere, traslare e, in alcune versioni, anche girare a 360°.

The Girevole bookcase solution is an ideal solution when you want to divide a room dynamically and flexibly, using an enclosing system made up of moveable modules. The innovative ceiling and floor track system can accommodate an unlimited number of elements that can slide, move sideways, and, in some versions, rotate through 360°.

### LIBRERIA GIREVOLE / GIREVOLE BOOKCASE

Tipologia libreria Bookcase typology	Altezza contenitore** Container height**	Altezza soffitto Ceiling height	Numero massimo di mensole Maximum number of shelves			Legno Wood			Codice Code
			P160	P250	P400	Nobilitato Talco Nobilitato Talco	Laccato Laquered	Essenza legno Wood essence	
Mensole sul fronte (P400) Shelves on the front (P400)	H2120	H2340-H2620	-	-	10*	€ 1.590	€ 2.690	€ 2.980	VT-S161
	H2400	H2620-H2900	-	-	12*	€ 1.730	€ 2.860	€ 3.090	VT-S163
	H2680	H2900-H3180	-	-	12*	€ 1.850	€ 2.980	€ 3.200	VT-S165
Mensole sul fronte (P250) e sul retro (P160) Shelves on the front (P250) and on the back (P160)	H2120	H2340-H2620	10*	10*	-	€ 1.590	€ 2.690	€ 2.980	VT-S160
	H2400	H2620-H2900	12*	12*	-	€ 1.730	€ 2.860	€ 3.090	VT-S162
	H2680	H2900-H3180	12*	12*	-	€ 1.850	€ 2.980	€ 3.200	VT-S164

\*una di queste mensole è già inclusa nel prezzo e posizionata a metà altezza

\*one of these shelves is already included in the price and positioned at half height

\*\*altezza del contenitore fissa, l'altezza del carrello girevole varia a seconda dell'altezza del soffitto

\*\*fixed container height, the height of the pivoting carriage changes depending on ceiling height

### MENSOLE OPZIONALI PER LIBRERIA GIREVOLE / OPTIONAL SHELVES FOR GIREVOLE BOOKCASE

Profondità mensola Shelf depth	Legno Wood			Codice Code
	Nobilitato Talco Nobilitato Talco	Laccato Laquered	Essenza legno Wood essence	
P160	€ 50	€ 85	€ 95	VT-S166
P250	€ 55	€ 95	€ 105	VT-S168
P400	€ 65	€ 115	€ 125	VT-S169

### ANTE PER LIBRERIA GIREVOLE / DOORS FOR GIREVOLE BOOKCASE

Altezza coppia di ante Pair of doors height	Legno Wood			Codice Code
	Nobilitato Talco Nobilitato Talco	Laccato Laquered	Essenza legno Wood essence	
H2120	€ 490	€ 990	€ 1.190	VTS-S180
H2400	€ 560	€ 1.060	€ 1.250	VTS-S182
H2680	€ 620	€ 1.120	€ 1.290	VTS-S184

### BINARI / BINARI

Tipologia binario Rail typology	Prezzo Price	Codice Code
Binario Uno a soffitto Ceiling Uno rail	€/ml 79	S078100
Binario Uno a pavimento Floor Uno rail	€/ml 53	S078200
Binario Uno a pavimento incassato Built-in floor Uno rail	€/ml 48	S078300
Binario Uno a pavimento incassato con inserto in alluminio Built-in floor Uno rail with aluminium insert	€/ml 74	S078400

### ACCESSORI / ACCESSORIES

Tipologia accessorio Accessory type	Prezzo Price	Codice Code
Asta appendiabiti Clothes rail	€ 80	VT-910

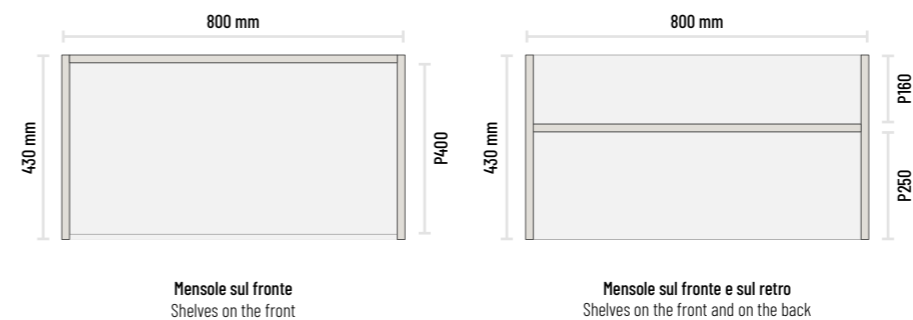

Mensole sul fronte  
Shelves on the front

Mensole sul fronte e sul retro  
Shelves on the front and on the back



Binario a soffitto  
Ceiling rail

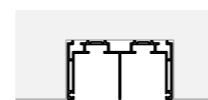

Binario a soffitto (incassato)  
Ceiling rail (built-in)



Binario a pavimento  
Built-in floor rail

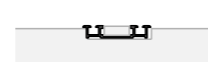

Binario a pavimento incassato  
Built-in floor rail



Binario a pavimento incassato  
con inserto alluminio  
Built-in floor rail  
with aluminium insert

# Libreria Line

## Line Bookcase

### Libreria a parete / Wall upright bookcase

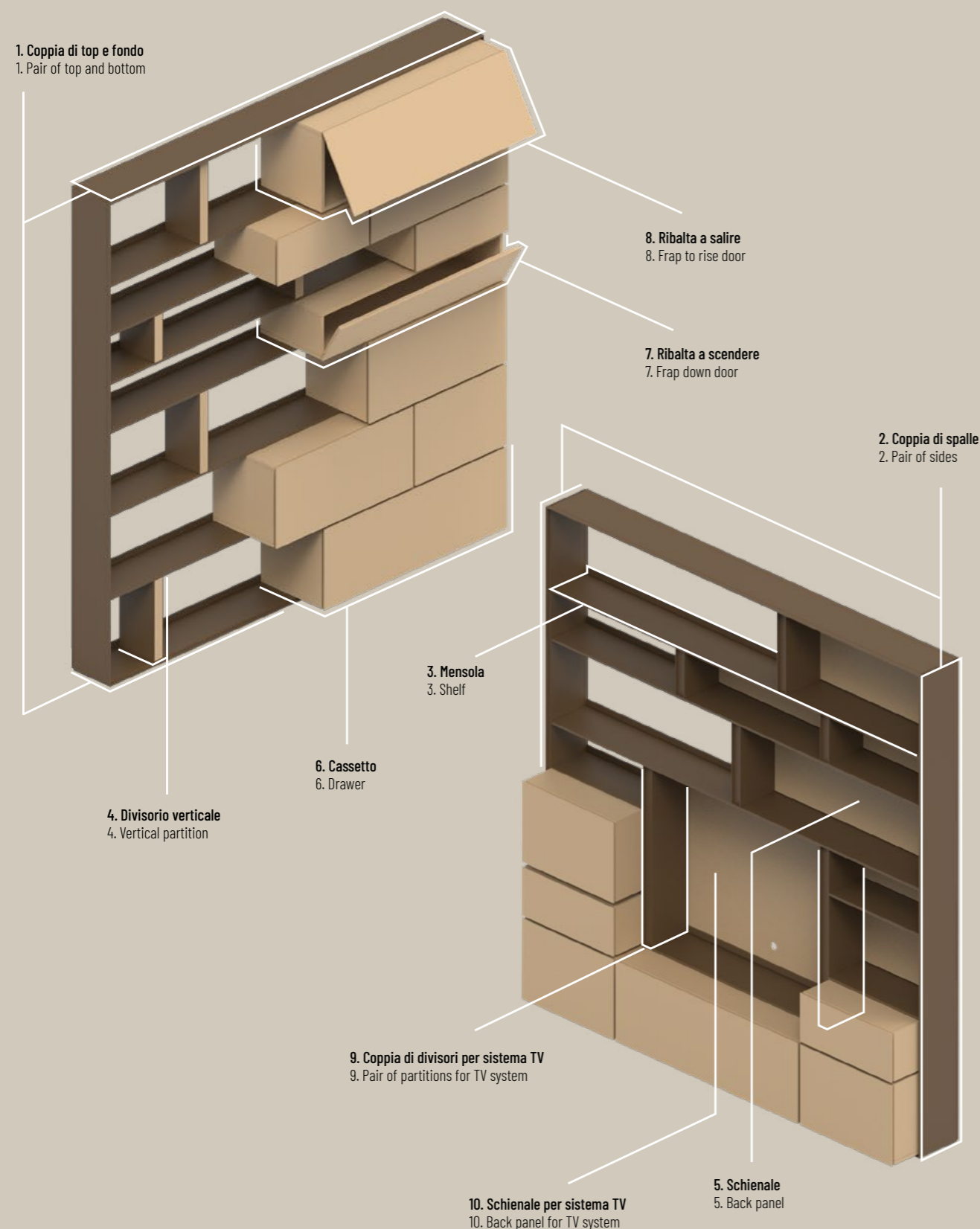

Una libreria dal design assoluto in cui il ripiano orizzontale diventa elemento strutturale e le altezze si sviluppano su volumi a forte spessore. Line è un sistema compositivo con cui giocare di contrasto tra pieni e vuoti in cui il profilo di alluminio diventa protagonista.

An authentic designer bookcase in which the horizontal shelf becomes a structural element, and the heights are built up on very thick volumes. Line is a modular system that can be used to play with full and empty spaces, in which the aluminium profile takes on a leading role.

### Componenti / Components

#### STRUTTURA / STRUCTURE

1. Coppia di Top e Fondo  
1. Pair of Top and Bottom
2. Coppia di spalle  
2. Pair of sides
3. Mensola  
3. Shelf

#### ELEMENTI / ELEMENTS

4. Divisorio verticale  
4. Vertical partition
5. Schienale  
5. Back panel

#### 6. Cassetto

6. Cassetto  
6. Drawer
7. Ribalta a scendere  
7. Flap down door
8. Ribalta a salire  
8. Flap to rise door
9. Coppia di divisori per sistema TV  
9. Pair of partitions for TV system
10. Schienale per sistema TV  
10. Back panel for TV system

### Moduli dimensionali / Dimensional modules

Modulo Module	Altezza spalle Sides height
H11	2800
H10	2545
H9	2289
H8	1854
H7	1599
H6	1419
H5	1344
H4	1184
H3	908
H2	728
H1	473
H0	293

Larghezza top e fondo  
Upper and lower width

Modulo  
Module

640	930	1230	1530	1830	2130	2430	2730	3030	3630	4230	4830	5430
L0	L1	L2	L3	L4	L5	L6	L7	L8	L9	L10	L11	L12



# Struttura libreria Line

## Line bookcase structure

### COPIA DI TOP E FONDO / PAIR OF TOP AND BOTTOM

Modulo dimensionale Dimensional module	Larghezza top e fondo Upper and lower width	Profondità top e fondo Top and bottom depth	Alluminio Aluminium		Codice Code
			Bianco Ral 9003 White Ral 9003	Custom Ral Custom Ral	
L0	L630	P224	€ 208	€ 312	LN-LA060
L1	L930	P224	€ 277	€ 416	LN-LA090
L2	L1230	P224	€ 358	€ 537	LN-LA120
L3	L1530	P224	€ 451	€ 624	LN-LA150
L4	L1830	P224	€ 520	€ 780	LN-LA180
L5	L2130	P224	€ 601	€ 901	LN-LA210
L6	L2430	P224	€ 624	€ 936	LN-LA240
L7	L2730	P224	€ 757	€ 1.138	LN-LA270
L8	L3030	P224	€ 971	€ 1.456	LN-LA300
L9	L3630	P224	€ 1.011	€ 1.520	LN-LA360
L10	L4230	P224	€ 1.300	€ 1.953	LN-LA420
L11	L4830	P224	€ 1.433	€ 2.149	LN-LA480
L12	L5430	P224	€ 1.433	€ 2.149	LN-LA540

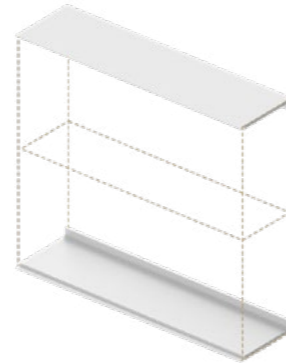

Coppia di top e fondo  
Pair of top and bottom

### COPIA DI SPALLE / PAIR OF SIDES

Modulo dimensionale Dimensional module	Altezza spalle Sides height	Profondità spalle Sides depth	Alluminio Aluminium					Codice Code		
			Bianco Ral 9003 White Ral 9003	Custom Ral Custom Ral	Versione A Version A	Versione B Version B	Versione C Version C	Versione D Version D	Versione E Version E	
H0	H240	P266	€ 237	€ 356	LN-H0A	-	-	-	-	-
H1	H473	P266	€ 237	€ 356	LN-H1A	-	-	-	-	-
H2	H728	P266	€ 300	€ 451	LN-H2A	LN-H2B	-	-	-	-
H3	H908	P266	€ 324	€ 584	LN-H3A	-	-	-	-	-
H4	H1164	P266	€ 428	€ 641	LN-H4A	LN-H4B	LN-H4C	-	-	-
H5	H1344	P266	€ 439	€ 659	LN-H5A	-	-	-	-	-
H6	H1419	P266	€ 462	€ 693	LN-H6A*	LN-H6B	LN-H6C**	LN-H6D	LN-H6E**	-
H7	H1599	P266	€ 480	€ 722	LN-H7A	LN-H7B	LN-H7C	LN-H7D	-	-
H8	H1854	P266	€ 532	€ 797	LN-H8A**	LN-H8B**	LN-H8C*	LN-H8D	LN-H8E*	-
H9	H2289	P266	€ 612	€ 919	LN-H9A*	LN-H9B*	-	-	-	-
H10	H2545	P266	€ 653	€ 982	LN-H10A**	LN-H10B**	LN-H10C*	-	-	-
H11	H2800	P266	€ 664	€ 1.000	LN-H11A**	LN-H11B**	LN-H11C*	LN-H11D*	-	-

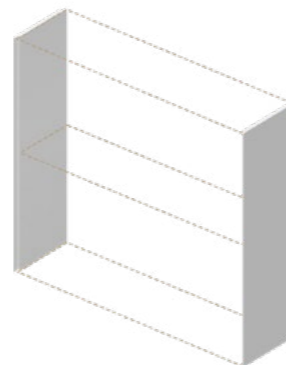

Coppia di spalle  
Pair of sides

\*Versione compatibile con coppia di spalle per sistema TV tipologia A / Version compatible with pair of sides for TV system type A

\*\*Versione compatibile con coppia di spalle per sistema TV tipologia B / Version compatible with pair of sides for TV system type B

### MENSOLE / SHELVES

Modulo dimensionale Dimensional module	Larghezza mensola Shelf width	Profondità mensola Shelf depth	Alluminio Aluminium		Codice Code
			Bianco Ral 9003 White Ral 9003	Custom Ral Custom Ral	
L0	L630	P224	€ 98	€ 148	LN-PL1
L1	L930	P224	€ 127	€ 191	LN-PL2
L2	L1230	P224	€ 162	€ 243	LN-PL3
L3	L1530	P224	€ 196	€ 295	LN-PL4
L4	L1830	P224	€ 225	€ 341	LN-PL5
L5	L2130	P224	€ 254	€ 381	LN-PL6
L6	L2430	P224	€ 277	€ 416	LN-PL7
L7	L2730	P224	€ 318	€ 480	LN-PL8
L8	L3030	P224	€ 387	€ 584	LN-PL9
L9	L3630	P224	€ 410	€ 618	LN-PL10
L10	L4230	P224	€ 503	€ 757	LN-PL11
L11	L4830	P224	€ 584	€ 878	LN-PL12
L12	L5430	P224	€ 584	€ 878	LN-PL13

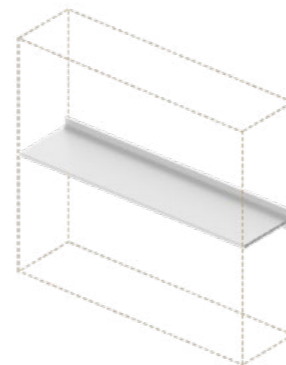

Mensola  
Shelf

# Versioni spalle per disposizione mensole

## Sides versions for shelves management

H Altezza vano  
H Compartment height

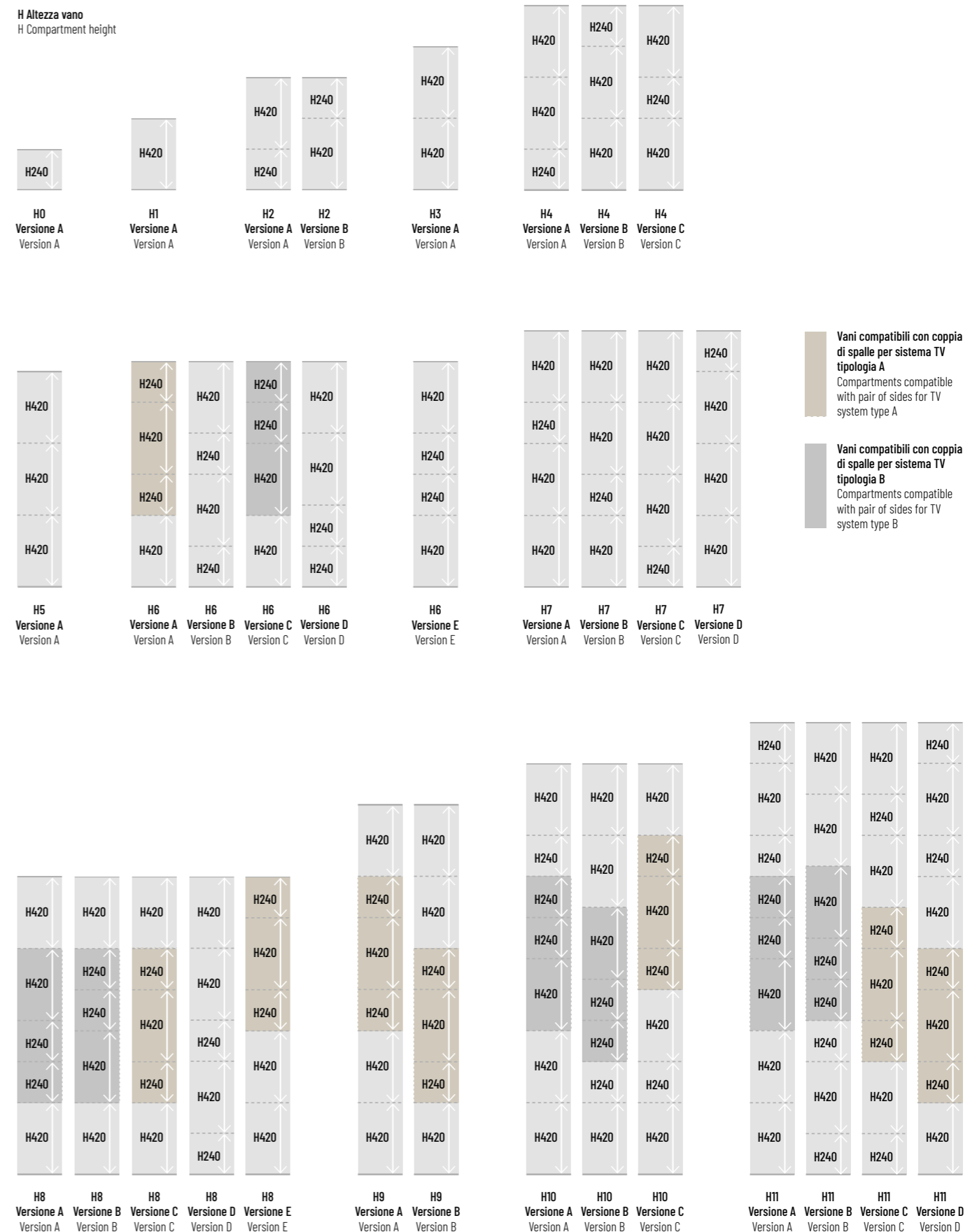

# Elementi libreria Line

## Line bookcase elements

### DIVISORIO VERTICALE / VERTICAL PARTITION

Altezza Height	Profondità Depth	Alluminio / Aluminium		Codice Code
		Bianco Ral 9003 White Ral 9003	Custom Ral Custom Ral	
H240	P225	€ 52	€ 75	LN-500
H420	P225	€ 69	€ 104	LN-502

Si consiglia di posizionare un numero divisori verticali tale da evitare vani vuoti di L<1500  
It is advisable to place a sufficient number of vertical dividers to avoid empty compartments of L<1500

### INSERTO PER DIVISORIO VERTICALE / INSERT FOR VERTICAL PARTITION

Altezza Height	Legno / Wood		Codice Code
	Essenza legno Wood essence	Nobilitato Nobilitato	
H240	€ 69	€ 30	LN-501
H420	€ 81	€ 42	LN-503

### SCHIENALE / BACK PANEL

Altezza vano Compartment height	Larghezza Width	Legno / Wood				Vetro / Glass				Codice Code
		Laccato standard Standard lacquered	Laccato custom RAL Custom RAL lacquered	Cat. A	Cat. B	Cat. C	Cat. D			
H240	L600	€ 127	€ 127	€ 61	€ 67	€ 85	€ 97	LN-510		
	L900	€ 150	€ 150	€ 73	€ 85	€ 115	€ 121	LN-512		
	L1200	€ 168	€ 168	€ 85	€ 103	€ 146	€ 170	LN-514		
H420	L600	€ 162	€ 162	€ 79	€ 91	€ 121	€ 133	LN-520		
	L900	€ 191	€ 191	€ 97	€ 115	€ 164	€ 182	LN-522		
	L1200	€ 231	€ 231	€ 115	€ 140	€ 206	€ 231	LN-524		

### CASSETTO / DRAWER

Altezza vano Compartment height	Larghezza Width	Legno / Wood		Codice / Code	
		Laccato standard Standard lacquered	Laccato custom RAL Custom RAL lacquered	Ribalta a scendere Flap down door	Ribalta a salire Flap to rise door
H240	L600	€ 445	€ 668	LN-400	LN-510
	L900	€ 537	€ 789	LN-420	LN-512
	L1200	€ 641	€ 923	LN-404	LN-514
H420	L600	€ 497	€ 745	LN-440	LN-520
	L900	€ 595	€ 893	LN-442	LN-522
	L1200	€ 699	€ 1.049	LN-444	LN-524

### RIBALTA / FLAP DOOR

Altezza vano Compartment height	Larghezza Width	Legno / Wood		Codice / Code	
		Laccato standard Standard lacquered	Laccato custom RAL Custom RAL lacquered	Ribalta a scendere Flap down door	Ribalta a salire Flap to rise door
H240	L600	€ 422	€ 645	LN-400	LN-510
	L900	€ 514	€ 766	LN-420	LN-512
	L1200	€ 618	€ 900	LN-404	LN-514
H420	L600	€ 474	€ 722	LN-440	LN-520
	L900	€ 572	€ 870	LN-442	LN-522
	L1200	€ 676	€ 1.026	LN-444	LN-524

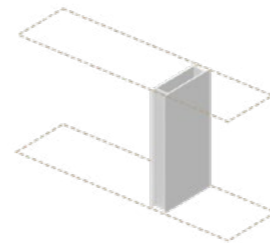

Divisorio verticale  
Vertical partition

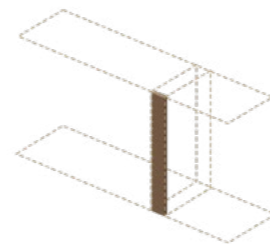

Inserto per divisorio verticale  
Inert for vertical partition

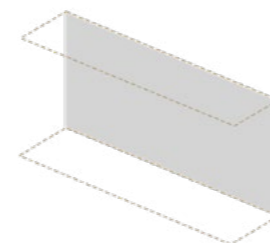

Schienale  
Back panel

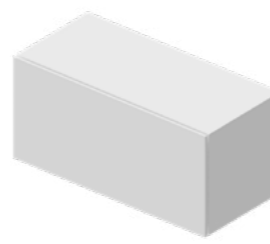

Cassetto  
Drawer

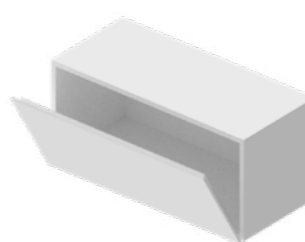

Ribalta a scendere  
Flap down door

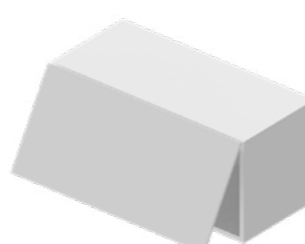

Ribalta a salire  
Flap to rise door

# Elementi libreria Line per sistema TV

## Line bookcase elements for TV system

### COPPIA DI DIVISORI PER SISTEMA TV / PAIR OF PARTITIONS FOR TV SYSTEM

Altezza Height	Profondità Depth	Alluminio / Aluminium		Codice / Code	
		Bianco Ral 9003 White Ral 9003	Custom Ral Custom Ral	Tipologia A Type A	Tipologia B Type B
H932	P225	€ 395	€ 595	LN-504	LN-506

### SCHIENALE PER SISTEMA TV / BACK PANEL FOR TV SYSTEM

Altezza vano Compartment height	Larghezza vano Compartment width	Legno / Wood		Codice / Code
		Laccato standard Standard lacquered	Laccato custom RAL Custom RAL lacquered	
H932	L1130	€ 358	€ 430	LN-540
	L1420	€ 445	€ 534	LN-542
	L1730	€ 532	€ 638	LN-544

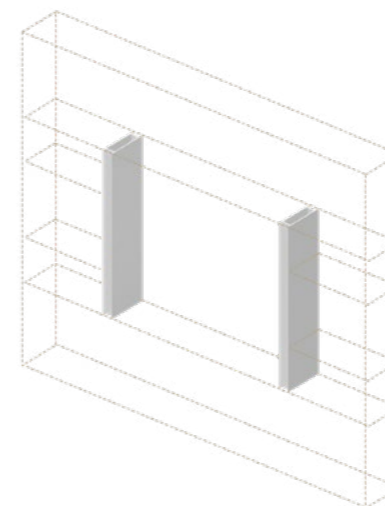

Coppia di divisori per sistema TV  
Pair of partitions for TV system

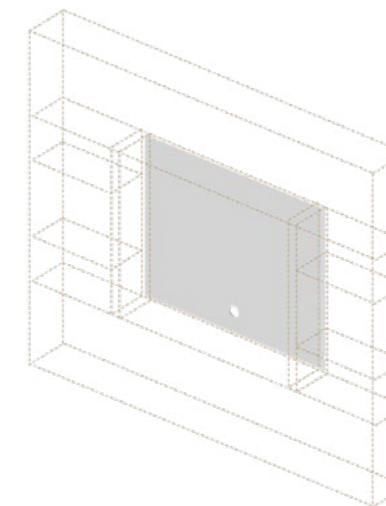

Schienale per sistema TV  
Back panel for TV system



Informazioni generali  
 General informations  
 Porte battenti con cornice  
 Hinged door and frame  
 Porte effetto filomuro  
 Flush-effect door  
 Porte filomuro  
 Flush door  
 Porte senza falso telaio  
 Door w/o basic door frame  
 Porte a scomparsa  
 Pocket door  
 Pan. scorrevoli o girevoli  
 Sliding or pivoting panels  
 Pareti divisorie  
 Partition wall  
 Boiserie  
 Boiserie  
 Cabine armadio  
 Walk-in closet  
 Librerie  
 Bookcase  
**Tavoli**  
**Table**



# TAVOLI TABLES

Un tavolo essenziale completa l'offerta di sistema per l'architettura d'interni. La tecnologia in alluminio e vetro assicura un'altissima qualità nei dettagli costruttivi e la massima durata.

An essential table completes our interior architectural system. Our aluminium and glass technology ensure very high quality construction details, and maximum lifespan.

## Dettagli / Details

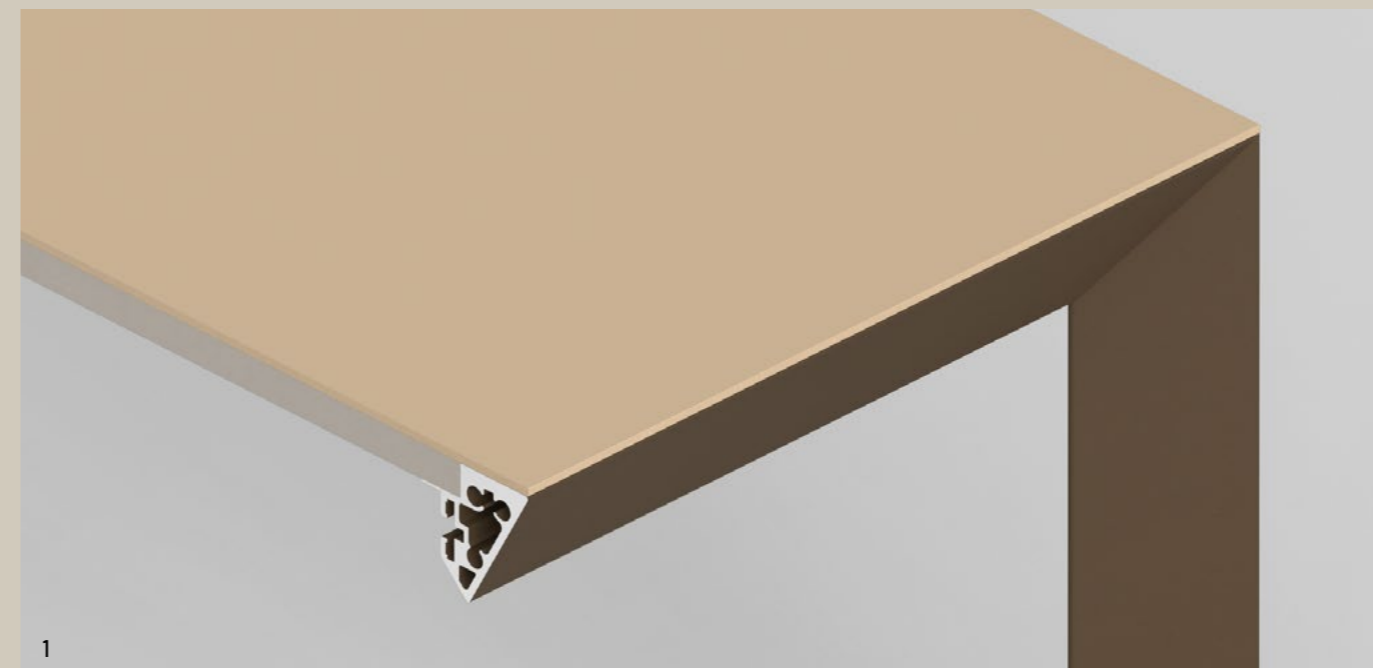

1. Sezione orizzontale tavolo Nile  
1. Vertical section Nile table

2. Sezione orizzontale gamba tavolo Nile  
2. Horizontal section Nile table leg

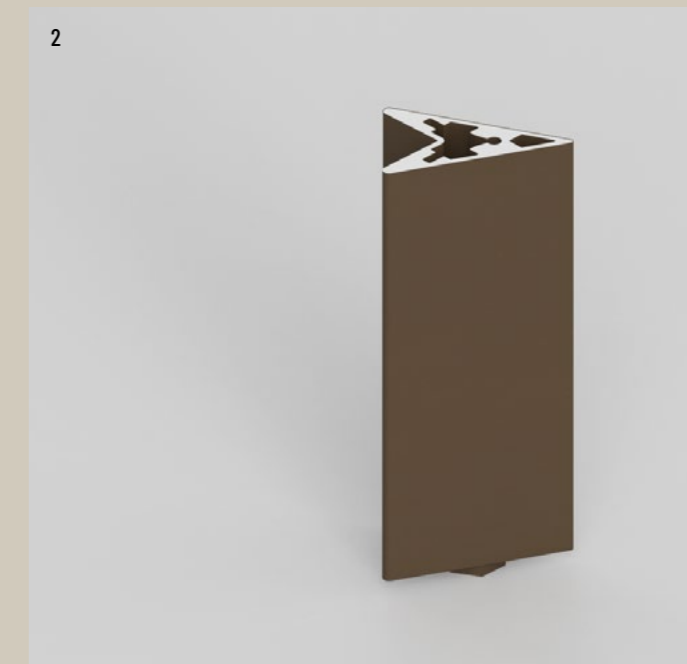

Informazioni generali  
 General informations  
 Porte battenti con cornice  
 Hinged door and frame  
 Porte effetto filomuro  
 Flush-effect door  
 Porte filomuro  
 Flush door  
 Porte senza falso telaio  
 Door w/o basic door frame  
 Porte a scomparsa  
 Pocket door  
 Pan. scorrevoli o girevoli  
 Sliding or pivoting panels  
 Pareti divisorie  
 Partition wall  
 Boiserie  
 Boiserie  
 Cabine armadio  
 Walk-in closet  
 Librerie  
 Bookcase  
**Tavoli**  
**Table**

# Tavolo Nile

## Nile table

Nile è un tavolo dalle linee estremamente semplici, realizzato con un profilo di alluminio che lo rende adatto sia al complesso mondo del contract, sia allo scenario domestico. La struttura estremamente rigida consente dimensioni importanti mantenendo la struttura minimale a 4 gambe senza supporto centrale.

Nile is a table with extremely simple lines, made of an aluminium profile which makes it suitable for both the complex world of contract and the domestic scenery. The extremely rigid frame allows large dimensions maintaining the minimal 4 legs structure without central support.

### TAVOLO NILE / NILE TABLE

Profondità Depth	Larghezza Length	Struttura alluminio anodizzato o verniciato Anodized or painted aluminum finishing structure			Struttura alluminio laccato Ral Ral lacquered aluminium structure			Codice Code
		Senza piano Without top	Piano vetro Glass top	Piano legno Wooden top	Senza piano Without top	Piano vetro Glass top	Piano legno Wooden top	
P=L Quadrato Square	L1200	€ 1.453	€ 1.751	€ 1.870	€ 1.672	€ 1.960	€ 2.138	NL-120
	L1201-L1499	€ 1.694	€ 2.185	€ 2.380	€ 1.946	€ 2.425	€ 2.689	NL-150X
	L1500	€ 1.594	€ 2.085	€ 2.280	€ 1.846	€ 2.325	€ 2.589	NL-150
	L1501-L1799	€ 1.843	€ 2.571	€ 2.860	€ 2.129	€ 2.843	€ 3.209	NL-180X
P800	L1800	€ 1.743	€ 2.471	€ 2.760	€ 2.029	€ 2.743	€ 3.109	NL-180
	L1200	€ 1.383	€ 1.586	€ 1.668	€ 1.585	€ 1.778	€ 1.915	NL-130P8
	L1201-L1499	€ 1.525	€ 1.765	€ 1.863	€ 1.738	€ 1.968	€ 2.123	NL-130P8X
	L1500	€ 1.425	€ 1.666	€ 1.763	€ 1.638	€ 1.868	€ 2.023	NL-150P8
P900	L1501-L1799	€ 1.588	€ 1.885	€ 2.005	€ 1.818	€ 2.104	€ 2.286	NL-150P8X
	L1800	€ 1.488	€ 1.785	€ 1.905	€ 1.718	€ 2.004	€ 2.186	NL-180P8
	L1801-L1999	€ 1.630	€ 1.964	€ 2.100	€ 1.872	€ 2.194	€ 2.395	NL-180P8X
	L2000	€ 1.530	€ 1.865	€ 2.000	€ 1.772	€ 2.094	€ 2.295	NL-200P8
P1300	L2001-L2999	€ 1.841	€ 2.362	€ 2.574	€ 2.138	€ 2.645	€ 2.937	NL-200P8X
	L3000	€ 1.741	€ 2.262	€ 2.474	€ 2.038	€ 2.545	€ 2.837	NL-300P8
	L1200	€ 1.406	€ 1.640	€ 1.734	€ 1.614	€ 1.838	€ 1.988	NL-130P9
	L1201-L1499	€ 1.549	€ 1.826	€ 1.937	€ 1.768	€ 2.034	€ 2.204	NL-130P9X
P900	L1500	€ 1.449	€ 1.726	€ 1.837	€ 1.668	€ 1.934	€ 2.104	NL-150P9
	L1501-L1799	€ 1.614	€ 1.954	€ 2.090	€ 1.849	€ 2.088	€ 2.378	NL-150P9X
	L1800	€ 1.514	€ 1.854	€ 1.990	€ 1.749	€ 2.078	€ 2.278	NL-180P9
	L1801-L1999	€ 1.657	€ 2.039	€ 2.193	€ 1.903	€ 2.274	€ 2.494	NL-180P9X
P1300	L2000	€ 1.557	€ 1.939	€ 2.093	€ 1.803	€ 2.174	€ 2.394	NL-200P9
	L2001-L2999	€ 1.871	€ 2.465	€ 2.705	€ 2.174	€ 2.753	€ 3.075	NL-200P9X
	L3000	€ 1.771	€ 2.365	€ 2.605	€ 2.074	€ 2.653	€ 2.975	NL-300P9
	L1800	€ 1.615	€ 2.128	€ 2.332	€ 1.873	€ 2.373	€ 2.647	NL-180P13
P1300	L1801-L1999	€ 1.762	€ 2.337	€ 2.565	€ 2.031	€ 2.592	€ 2.894	NL-180P13X
	L2000	€ 1.662	€ 2.237	€ 2.465	€ 1.931	€ 2.492	€ 2.794	NL-200P13
	L2001-L2999	€ 1.994	€ 2.879	€ 3.229	€ 2.320	€ 3.188	€ 3.627	NL-200P13X
L3000	€ 1.894	€ 2.779	€ 3.129	€ 2.220	€ 3.088	€ 3.527	NL-300P13	

### ACCESSORI / ACCESSORIES

Tipologia accessorio Accessory type	Prezzo Price	Codice Code
Kit multipresa smart Smart power strip kit	€ 150	NL-PS1

Il kit multipresa smart viene posizionato al centro del piano se non specificato diversamente  
The smart power strip kit placed in the center of the top unless otherwise specified

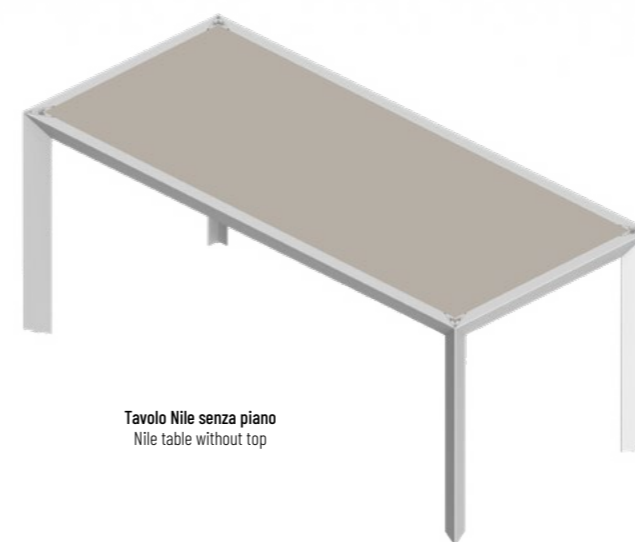

Tavolo Nile senza piano  
Nile table without top



Tavolo Nile con piano in vetro  
Nile table with glass top

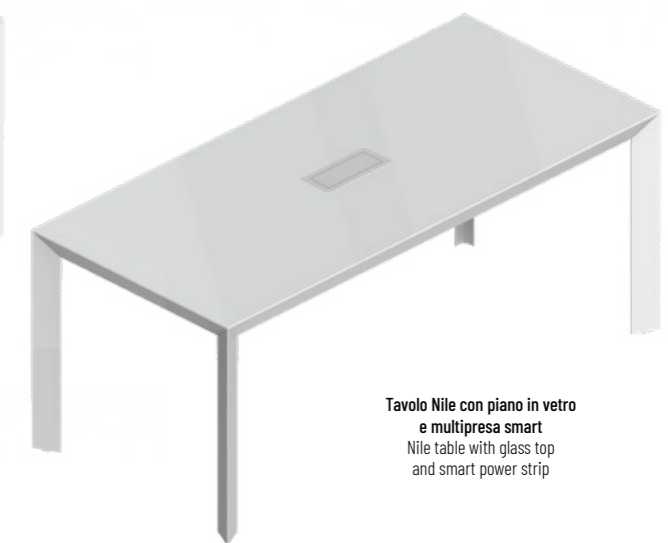

Tavolo Nile con piano in vetro  
e multipresa smart  
Nile table with glass top  
and smart power strip



Tavolo Nile con piano in legno  
Nile table with wooden top

# ALBED LISTINO 2024

## ALBED PRICE BOOK 2024

### ALBED

Siamo un'azienda produttiva con un dna metalmeccanico legato alla lavorazione dell'alluminio dove le competenze tecniche diventano strategiche per assicurare un servizio al progetto affidabile e di qualità. Un brand che fa del design, dell'esclusività e della cura del dettaglio il suo carattere distintivo e che grazie ad un team organizzato, collaborativo e dinamico sviluppa soluzioni funzionali al progetto.

In essence, we are an engineering company that works with aluminium, in which technical skills become strategic for ensuring reliable, high quality service for any project. This brand makes design, exclusivity, and attention to detail its distinctive character and, thanks to a well organised, collaborative and dynamic team, we develop solutions to suit the project.

[www.albed.it](http://www.albed.it)

### LISTINO 2024 V1.6 PRICE BOOK 2024 V1.6

Nell'ottica di un continuo sviluppo del prodotto, la ditta si riserva il diritto di cambiare specifiche, design e materiali in qualsiasi momento e senza preavviso. I colori evidenziati hanno il solo scopo illustrativo e sono tanto accurati quanto il processo di stampa può permettere.

With the aim of a continuous product development, the company reserves the right to change specifications, design and materials at any time and without notice. The colours shown are for illustrative purposes only and they are as accurate as the printing process can permit.

**ALBED Sede operativa**  
Via San Martino  
20834 Nova Milanese (MB),  
Italia  
Tel +39 0362 367112

**ALBED Flagship store**  
Via Gonzaga 7  
20123 Milano (MI)  
Tel +39 02 76340610

Process Design  
Customer Experience

by TIPIC

Tipic è una consultancy design driven che supporta le aziende nell'innovare la propria proposta di valore e nello sviluppare la propria customer experience

Tipic is a design driven consultancy that supports companies to innovate their value proposition and to develop their own customer experience

[www.tipic.it](http://www.tipic.it)